

**IEEE Standard for
Local and metropolitan area networks—**

**Timing and Synchronization for
Time-Sensitive Applications in
Bridged Local Area Networks**

IEEE Computer Society

Sponsored by the
LAN/MAN Standards Committee

IEEE
3 Park Avenue
New York, NY 10016-5997
USA

IEEE Std 802.1AS™-2011

30 March 2011

**IEEE Standard for
Local and metropolitan area networks—
Timing and Synchronization for
Time-Sensitive Applications in
Bridged Local Area Networks**

Sponsor
LAN/MAN Standards Committee
of the
IEEE Computer Society

Approved 10 February 2011
IEEE SA-Standards Board

Abstract: This standard defines a protocol and procedures for the transport of timing over bridged and virtual bridged local area networks. It includes the transport of synchronized time, the selection of the timing source (i.e., best master), and the indication of the occurrence and magnitude of timing impairments (i.e., phase and frequency discontinuities).

Keywords: best master, frequency offset, grandmaster, IEEE 802.1AS, phase offset, synchronization, syntonization, time-aware system

The Institute of Electrical and Electronics Engineers, Inc.
3 Park Avenue, New York, NY 10016-5997, USA

Copyright © 2011 by the Institute of Electrical and Electronics Engineers, Inc.
All rights reserved. Published 30 March 2011. Printed in the United States of America.

IEEE and 802 are registered trademarks in the U.S. Patent & Trademark Office, owned by the Institute of Electrical and Electronics Engineers, Incorporated.

POSIX is a trademark of the Institute of Electrical and Electronics Engineers, Incorporated.

MoCA is a registered trademark of the Multimedia over Coax Alliance.

PDF: ISBN 978-0-7381-6536-3 STD97070
Print: ISBN 978-0-7381-6537-0 STDPD97070

IEEE prohibits discrimination, harassment and bullying. For more information, visit <http://www.ieee.org/web/aboutus/whatis/policies/p9-26.html>. No part of this publication may be reproduced in any form, in an electronic retrieval system or otherwise, without the prior written permission of the publisher.

IEEE Standards documents are developed within the IEEE Societies and the Standards Coordinating Committees of the IEEE Standards Association (IEEE-SA) Standards Board. The IEEE develops its standards through a consensus development process, approved by the American National Standards Institute, which brings together volunteers representing varied viewpoints and interests to achieve the final product. Volunteers are not necessarily members of the Institute and serve without compensation. While the IEEE administers the process and establishes rules to promote fairness in the consensus development process, the IEEE does not independently evaluate, test, or verify the accuracy of any of the information or the soundness of any judgments contained in its standards.

Use of an IEEE Standard is wholly voluntary. The IEEE disclaims liability for any personal injury, property or other damage, of any nature whatsoever, whether special, indirect, consequential, or compensatory, directly or indirectly resulting from the publication, use of, or reliance upon this, or any other IEEE Standard document.

The IEEE does not warrant or represent the accuracy or content of the material contained herein, and expressly disclaims any express or implied warranty, including any implied warranty of merchantability or fitness for a specific purpose, or that the use of the material contained herein is free from patent infringement. IEEE Standards documents are supplied "AS IS."

The existence of an IEEE Standard does not imply that there are no other ways to produce, test, measure, purchase, market, or provide other goods and services related to the scope of the IEEE Standard. Furthermore, the viewpoint expressed at the time a standard is approved and issued is subject to change brought about through developments in the state of the art and comments received from users of the standard. Every IEEE Standard is subjected to review at least every five years for revision or reaffirmation, or every ten years for stabilization. When a document is more than five years old and has not been reaffirmed, or more than ten years old and has not been stabilized, it is reasonable to conclude that its contents, although still of some value, do not wholly reflect the present state of the art. Users are cautioned to check to determine that they have the latest edition of any IEEE Standard.

In publishing and making this document available, the IEEE is not suggesting or rendering professional or other services for, or on behalf of, any person or entity. Nor is the IEEE undertaking to perform any duty owed by any other person or entity to another. Any person utilizing this, and any other IEEE Standards document, should rely upon his or her independent judgment in the exercise of reasonable care in any given circumstances or, as appropriate, seek the advice of a competent professional in determining the appropriateness of a given IEEE standard.

Interpretations: Occasionally questions may arise regarding the meaning of portions of standards as they relate to specific applications. When the need for interpretations is brought to the attention of IEEE, the Institute will initiate action to prepare appropriate responses. Since IEEE Standards represent a consensus of concerned interests, it is important to ensure that any interpretation has also received the concurrence of a balance of interests. For this reason, IEEE and the members of its societies and Standards Coordinating Committees are not able to provide an instant response to interpretation requests except in those cases where the matter has previously received formal consideration. A statement, written or oral, that is not processed in accordance with the IEEE-SA Standards Board Operations Manual shall not be considered the official position of IEEE or any of its committees and shall not be considered to be, nor be relied upon as, a formal interpretation of the IEEE. At lectures, symposia, seminars, or educational courses, an individual presenting information on IEEE standards shall make it clear that his or her views should be considered the personal views of that individual rather than the formal position, explanation, or interpretation of the IEEE.

Comments for revision of IEEE Standards are welcome from any interested party, regardless of membership affiliation with IEEE. Suggestions for changes in documents should be in the form of a proposed change of text, together with appropriate supporting comments. Recommendations to change the status of a stabilized standard should include a rationale as to why a revision or withdrawal is required. Comments and recommendations on standards, and requests for interpretations should be addressed to:

Secretary, IEEE-SA Standards Board
445 Hoes Lane
Piscataway, NJ 08854
USA

Authorization to photocopy portions of any individual standard for internal or personal use is granted by The Institute of Electrical and Electronics Engineers, Inc., provided that the appropriate fee is paid to Copyright Clearance Center. To arrange for payment of licensing fee, please contact Copyright Clearance Center, Customer Service, 222 Rosewood Drive, Danvers, MA 01923 USA; +1 978 750 8400. Permission to photocopy portions of any individual standard for educational classroom use can also be obtained through the Copyright Clearance Center.

Introduction

This introduction is not part of IEEE Std 802.1AS-2011, IEEE Standard for Local and metropolitan area networks—Timing and Synchronization for Time-Sensitive Applications in Bridged Local Area Networks.

This standard specifies the protocol and procedures used to ensure that the synchronization requirements are met for time-sensitive applications, such as audio and video, across bridged and virtual bridged local area networks consisting of LAN media where the transmission delays are fixed and symmetrical; for example, IEEE 802.3TM full-duplex links. This includes the maintenance of synchronized time during normal operation and following addition, removal, or failure of network components and network reconfiguration. It specifies the use of IEEE 1588TM specifications where applicable in the context of IEEE Std 802.1DTM-2004 and IEEE Std 802.1QTM-2005.^a Synchronization to an externally provided timing signal (e.g., a recognized timing standard such as UTC or TAI) is not part of this standard but is not precluded.

This is the first edition of IEEE Std 802.1AS.

This standard contains state-of-the-art material. The area covered by this standard is undergoing evolution. Revisions are anticipated within the next few years to clarify existing material, to correct possible errors, and to incorporate new related material. Information on the current state of this and other IEEE 802[®] standards may be obtained from:

Secretary, IEEE-SA Standards Board
445 Hoes Lane
Piscataway, NJ 08854
USA

Notice to users

Laws and regulations

Users of these documents should consult all applicable laws and regulations. Compliance with the provisions of this standard does not imply compliance to any applicable regulatory requirements. Implementers of the standard are responsible for observing or referring to the applicable regulatory requirements. IEEE does not, by the publication of its standards, intend to urge action that is not in compliance with applicable laws, and these documents may not be construed as doing so.

Copyrights

This document is copyrighted by the IEEE. It is made available for a wide variety of both public and private uses. These include both use, by reference, in laws and regulations, and use in private self-regulation, standardization, and the promotion of engineering practices and methods. By making this document available for use and adoption by public authorities and private users, the IEEE does not waive any rights in copyright to this document.

^aInformation on references can be found in Clause 2.

Updating of IEEE documents

Users of IEEE standards should be aware that these documents may be superseded at any time by the issuance of new editions or may be amended from time to time through the issuance of amendments, corrigenda, or errata. An official IEEE document at any point in time consists of the current edition of the document together with any amendments, corrigenda, or errata then in effect. In order to determine whether a given document is the current edition and whether it has been amended through the issuance of amendments, corrigenda, or errata, visit the IEEE Standards Association website at <http://ieeexplore.ieee.org/xpl/standards.jsp>, or contact the IEEE at the address listed previously.

For more information about the IEEE Standards Association or the IEEE standards development process, visit the IEEE-SA website at <http://standards.ieee.org>.

Errata

Errata, if any, for this and all other standards can be accessed at the following URL: <http://standards.ieee.org/reading/ieee/updates/errata/index.html>. Users are encouraged to check this URL for errata periodically.

Interpretations

Current interpretations can be accessed at the following URL: <http://standards.ieee.org/reading/ieee/interp/index.html>.

Patents

Attention is called to the possibility that implementation of this standard may require use of subject matter covered by patent rights. By publication of this standard, no position is taken with respect to the existence or validity of any patent rights in connection therewith. A patent holder or patent applicant has filed a statement of assurance that it will grant licenses under these rights without compensation or under reasonable rates, with reasonable terms and conditions that are demonstrably free of any unfair discrimination to applicants desiring to obtain such licenses. Other Essential Patent Claims may exist for which a statement of assurance has not been received. The IEEE is not responsible for identifying Essential Patent Claims for which a license may be required, for conducting inquiries into the legal validity or scope of Patents Claims, or determining whether any licensing terms or conditions provided in connection with submission of a Letter of Assurance, if any, or in any licensing agreements are reasonable or non-discriminatory. Users of this standard are expressly advised that determination of the validity of any patent rights, and the risk of infringement of such rights, is entirely their own responsibility. Further information may be obtained from the IEEE Standards Association.

Participants

At the time this standard was submitted to the IEEE-SA Standards Board for approval, the IEEE 802.1 Working Group had the following membership:

Tony Jeffree, *IEEE 802.1 Working Group Chair*
Paul Congdon, *IEEE 802.1 Vice Chair*
Michael Johas Teener, *Audio-Video Bridging Task Group Chair*
Geoffrey Garner, *Editor*

IEEE 802.1AS Clause Editors
Christopher Hall, *Clause 5, Annex A*
Kevin B. Stanton, *Clause 5, Clause 12, Annex A*
Michael Johas Teener, *Clause 7*
Yongbum Kim, *Clause 15*
Yuanqiu Luo, **Frank Effenberger**, *Clause 13*
Philippe Klein, *Annex F*

Zehavit Alon
Ting Ao
Wanqun Bao
Paul Bottorff
Rudolf Brandner
Craig Carlson
Diego Crupnicoff
Claudio Desanti
Zheming Ding
Donald Eastlake, 3rd
Janos Farkas
Donald Fedyk
Norman Finn
Ilango Ganga
Anoop Ghanwani

Eric Gray
Craig Gunther
Stephen Haddock
Daya Kamath
Hal Keen
Michael Krause
Vinod Kumar
Lin Li
Ben Mack-Crane
Menu Menuchehry
John Messenger
John Morris
Eric Multanen
David Olsen

Donald Pannell
Glenn Parsons
Joseph Pelissier
Karen Randall
Derek Rohde
Dan Romascanu
Jessy Rouyer
Panagiotis Saltsidis
Michael Seaman
Rakesh Sharma
Takeshi Shimizu
Nurit Sprecher
Robert Sultan
Patricia Thaler
Chien-Hsien Wu

The following members of the individual balloting committee voted on this standard. Balloters may have voted for approval, disapproval, or abstention.

Thomas Alexander	Akio Iso	Stephen Palm
Butch Anton	Atsushi Ito	Glenn Parsons
Danilo Antonelli	Raj Jain	Subburajan
Galina Antonova	Tony Jeffree	Ponnuswamy
Lee Armstrong	Girault Jones	Maximilian Riegel
Hugh Barrass	Shinkyō Kaku	Robert Robinson
William Byrd	Piotr Karocki	Jessy Rouyer
Juan Carreon	Stuart J. Kerry	Randall Safier
Keith Chow	Max Kicherer	John Santhoff
Charles Cook	Yongbum Kim	Peter Saunderson
Wael Diab	Gerald L. Kolbe	Bartien Sayogo
Russell Dietz	Seiji Kozaki	Shusaku Shimada
Thomas Dineen	Bruce Kraemer	Gil Shultz
Frank Effenberger	Paul Lambert	Matthew Squire
C. Fitzgerald	Jeremy Landt	Manikantan Srinivasan
Prince Francis	Li Li	Kevin B. Stanton
Yukihiro Fujimoto	Greg Luri	Thomas Starai
Geoffrey Garner	Eric Lynskey	Walter Struppler
Devon Gayle	Elvis Maculuba	Joseph Tardo
Mariana Goldhamer	Arthur Marris	William Taylor
Sergiu Goma	Peter Martini	Michael Johas Teener
David Goodall	Jeffery Masters	Patricia Thaler
Randall Groves	Jonathon Mclendon	David Thompson
Craig Gunther	Gary Michel	Geoffrey Thompson
C. Guy	Jose Morales	Solomon Trainin
Joseph Gwinn	Bruce Muschlitz	Mark-Rene Uchida
Stephen Haddock	Michael S. Newman	Dmitri Varsanofiev
Marek Hajduczenia	Nick S. A. Nikjoo	Prabodh Varshney
Christopher Hall	Paul Nikolich	Ludwig Winkel
Karl Heubaum	Satoshi Obara	Kunpeng Wu
David Hunter	David Olsen	Oren Yuen
C. Huntley		Zhen Zhou

When the IEEE-SA Standards Board approved this standard on 10 February 2011, it had the following membership:

Robert M. Grow, *Chair*
Richard H. Hulett, *Vice Chair*
Steve M. Mills, *Past Chair*
Judith Gorman, *Secretary*

Karen Bartleson
Victor Berman
Ted Burse
Clint Chaplin
Andy Drozd
Alexander Gelman
Jim Hughes

Young Kyun Kim
Joseph L. Koepfinger*
John Kulick
David J. Law
Hung Ling
Oleg Logvinov
Ted Olsen

Ronald C. Petersen
Thomas Prevost
Jon Walter Rosdahl
Sam Sciacca
Mike Seavey
Curtis Siller
Don Wright

*Member Emeritus

Also included are the following nonvoting IEEE-SA Standards Board liaisons:

Satish K. Aggarwal, *NRC Representative*
Richard DeBlasio, *DOE Representative*
Michael Janezic, *NIST Representative*

Lisa Perry
IEEE Standards Program Manager, Document Development

Kathryn Bennett
IEEE Standards Program Manager, Technical Program Development

Contents

1.	Overview.....	1
	1.1 Scope.....	1
	1.2 Purpose.....	2
2.	Normative references.....	3
3.	Definitions.....	5
4.	Acronyms and abbreviations.....	9
5.	Conformance.....	11
	5.1 Requirements terminology.....	11
	5.2 Protocol Implementation Conformance Statement (PICS).....	11
	5.3 Time-aware Bridge and end station requirements.....	11
	5.4 MAC-specific timing and synchronization methods for IEEE 802.3 full-duplex links.....	12
	5.5 MAC-specific timing and synchronization methods for IEEE Std 802.11-2007.....	12
	5.6 MAC-specific timing and synchronization methods for IEEE 802.3 EPON.....	12
	5.7 MAC-specific timing and synchronization methods for coordinated shared network (CSN)....	13
6.	Conventions.....	15
	6.1 General.....	15
	6.2 Service specification method and notation.....	15
	6.3 Data types and on-the-wire formats.....	15
7.	Time synchronization model for a bridged local area network.....	19
	7.1 General.....	19
	7.2 Architecture of a time-aware bridged local area network.....	19
	7.3 Time synchronization.....	21
	7.4 Time-aware system architecture.....	24
	7.5 Differences between gPTP and PTP.....	25
8.	IEEE 802.1AS concepts and terminology.....	27
	8.1 gPTP domain.....	27
	8.2 Timescale.....	27
	8.3 Communication path asymmetry.....	28
	8.4 Messages.....	29
	8.5 Ports.....	30
	8.6 Time-aware system characterization.....	32
9.	Application interfaces.....	37
	9.1 Overview of the interfaces.....	37
	9.2 ClockSourceTime interface.....	38
	9.3 ClockTargetEventCapture interface.....	38
	9.4 ClockTargetTriggerGenerate interface.....	39
	9.5 ClockTargetClockGenerator interface.....	40
	9.6 ClockTargetPhaseDiscontinuity interface.....	41

10.	Media-independent layer specification	43
	10.1 Overview	43
	10.2 Time-synchronization state machines	44
	10.3 Best master clock selection and announce interval setting state machines	67
	10.4 Message attributes	85
	10.5 Message formats	87
	10.6 Protocol timing characterization	95
11.	Media-dependent layer specification for full-duplex, point-to-point links	99
	11.1 Overview	99
	11.2 State machines for MD entity specific to full-duplex, point-to-point links	105
	11.3 Message attributes	122
	11.4 Message formats	124
	11.5 Protocol timing characterization	131
12.	Media-dependent layer specification for IEEE 802.11 links	133
	12.1 Overview	133
	12.2 Messages	135
	12.3 Determination of asCapable	135
	12.4 State machines	136
	12.5 Format of VendorSpecific information element	143
	12.6 Synchronization message interval	144
13.	Media-dependent layer specification for interface to IEEE 802.3 Ethernet passive optical network link	145
	13.1 Overview	145
	13.2 Message attributes	149
	13.3 Message format	149
	13.4 Determination of asCapable	151
	13.5 Layering for IEEE 802.3 EPON links	151
	13.6 Service interface definitions	152
	13.7 MD entity global variables	154
	13.8 State machines	154
	13.9 Message transmission intervals	158
14.	Timing and synchronization management	159
	14.1 General	159
	14.2 Default Parameter Data Set	159
	14.3 Current Parameter Data Set	161
	14.4 Parent Parameter Data Set	164
	14.5 Time Properties Parameter Data Set	165
	14.6 Port Parameter Data Set	166
	14.7 Port Parameter Statistics	170
	14.8 Acceptable Master Table Parameter Data Set	173
15.	Managed object definitions	175
	15.1 Internet Standard Management Framework	175
	15.2 Structure of the MIB	175
	15.3 Security considerations	175
	15.4 Textual conventions defined in this MIB	179
	15.5 IEEE 802.1AS MIB module	179

Annex A (normative) Protocol Implementation Conformance Statement (PICS) proforma	231
A.1 Introduction.....	231
A.2 Abbreviations and special symbols.....	231
A.3 Instructions for completing the PICS proforma.....	232
A.4 PICS proforma for IEEE Std 802.1AS-2011	233
A.5 Major capabilities	235
A.6 Media access control methods	236
A.7 Minimal time-aware system.....	236
A.8 Signalling.....	237
A.9 Best master clock	238
A.10 Grandmaster-capable system	239
A.11 Media-independent master	240
A.12 Media-dependent, full-duplex, point-to-point link.....	241
A.13 Media-dependent IEEE 802.11 link.....	243
A.14 Media-dependent IEEE 802.3 EPON link	243
A.15 Media-dependent CSN link.....	244
A.16 Media-dependent MoCA link	244
A.17 Media-dependent ITU-T G.hn link	244
 Annex B (normative) Performance requirements	 245
B.1 LocalClock requirements	245
B.2 Time-aware system requirements	249
B.3 End-to-end time-synchronization performance	250
B.4 End-to-end jitter and wander performance	250
 Annex C (informative) Time-scales and epochs.....	 253
C.1 Overview.....	253
C.2 TAI and UTC	253
C.3 NTP and GPS.....	254
C.4 Time-scale conversions.....	255
C.5 Time zones and GMT	256
 Annex D (normative) State diagram notation.....	 257
 Annex E (normative) Media-dependent layer specification for CSN Network.....	 259
E.1 Overview.....	259
E.2 Coordinated Shared Network characteristics.....	259
E.3 Layering for CSN links.....	260
E.4 Path delay measurement over a CSN backbone	262
E.5 Synchronization messages.....	265
E.6 Specific CSN requirements.....	268
E.7 Grandmaster capability	269
E.8 CSN clock and node requirements.....	269
 Annex F (informative) PTP profile included in this standard	 271
F.1 Identification.....	271
F.2 PTP attribute values	271
F.3 PTP options.....	271
F.4 LocalClock and time-aware system performance requirements.....	272
 Annex G (informative) Bibliography	 273

List of figures

Figure 7-1—Time-aware network example.....	20
Figure 7-2—Time-aware network of Figure 7-1 after an access network link failure	21
Figure 7-3— Example delay measurement	22
Figure 7-4—Time-aware system model	24
Figure 8-1—Propagation asymmetry.....	28
Figure 8-2—Definition of message timestamp point, reference plane, timestamp measurement plane, and latency constants	30
Figure 9-1—Application interfaces	37
Figure 10-1—Model for media-independent layer of time-aware system.....	44
Figure 10-2—Time-synchronization state machines—overview and interrelationships.....	46
Figure 10-3—SiteSyncSync state machine.....	56
Figure 10-4—PortSyncSyncReceive state machine	58
Figure 10-5—ClockMasterSyncSend state machine	60
Figure 10-6—ClockMasterSyncOffset state machine	61
Figure 10-7—ClockMasterSyncReceive state machine	63
Figure 10-8—PortSyncSyncSend state machine	65
Figure 10-9—ClockSlaveSync state machine	67
Figure 10-10—Example master/slave hierarchy of time-aware systems	69
Figure 10-11—Best master clock selection state machines—overview and interrelationships	74
Figure 10-12—PortAnnounceReceive state machine.....	79
Figure 10-13—PortAnnounceInformation state machine.....	80
Figure 10-14—PortRoleSelection state machine.....	83
Figure 10-15—PortAnnounceTransmit state machine	84
Figure 10-16—AnnounceIntervalSetting state machine.....	85
Figure 11-1—Propagation delay measurement using peer delay mechanism	100
Figure 11-2—Transport of time-synchronization information	102
Figure 11-3—Model for time-aware system with full-duplex, point-to-point links.....	105
Figure 11-4—Detail of MD entity time-synchronization state machines for full-duplex, point-to-point links	106
Figure 11-5—Peer delay mechanism state machines—overview and interrelationships.....	106
Figure 11-6—MDSyncReceiveSM state machine.....	111
Figure 11-7—MDSyncSendSM state machine.....	114
Figure 11-8—MDPdelayReq state machine	118
Figure 11-9—MDPdelayResp state machine	120
Figure 11-10—LinkDelaySyncIntervalSetting state machine	121
Figure 12-1—Timing measurement procedure for IEEE 802.11 links	134
Figure 12-2—Media-dependent and lower entities in stations with IEEE 802.11 links	135
Figure 12-3—Master state machine.....	137
Figure 12-4—Slave state machine	141
Figure 12-5—Format of VendorSpecific information element when Type = 0	143
Figure 13-1—IEEE 802.3 EPON time-synchronization interfaces	148
Figure 13-2—IEEE 802.3 EPON interface model.....	152
Figure 13-3—State machine for IEEE 802.3 EPON requester.....	156
Figure 13-4—State machine for IEEE 802.3 EPON responder.....	157
Figure B.1—Wander generation (TDEV) requirement for LocalClock entity.....	247
Figure B.2—ADEV limit corresponding to wander generation requirement of Figure B.1	248
Figure B.3—PTPDEV limit corresponding to wander generation requirement of Figure B.1	249
Figure B.4—MTIE masks met for maximum endpoint filter bandwidths of Table B.4	251
Figure E.1—Example of CSN backbone in an AVB LAN	260
Figure E.2—Media-dependent and lower entities in CSN nodes	261
Figure E.3—Path types over CSN as IEEE 802.1AS backbone.....	262

Figure E.4—Propagation delay and residence time over a CSN Backbone.....	262
Figure E.5—CSN node-to-node path delay measurement.....	263
Figure E.6—IEEE 802.1AS Sync Message Propagation over the CSN backbone	265

List of tables

Table 6-1—Primitive data types	15
Table 8-1—Illustration of formation of clockIdentity from EUI-48	31
Table 8-2—Default values for priority1, for the respective media	33
Table 8-3—timeSource enumeration	36
Table 10-1—Port role definitions	68
Table 10-2—Destination address for Announce and Signaling messages	86
Table 10-3—Ethertype for Announce and Signaling messages	86
Table 10-4—PTP message header	88
Table 10-5—Values for messageType field	88
Table 10-6—Values of flag bits	89
Table 10-7—Announce message fields	90
Table 10-8—Path trace TLV	91
Table 10-9—Signaling message fields	92
Table 10-10—Message interval request TLV	93
Table 10-11—Interpretation of special values of linkDelayInterval	94
Table 10-12—Interpretation of special values of timeSyncInterval	94
Table 10-14—Definitions of bits of flags field of message interval request TLV	95
Table 10-13—Interpretation of special values of announceInterval	95
Table 11-1—Destination address for Sync, Follow_Up, Pdelay_Req, Pdelay_Resp, and Pdelay_Resp_Follow_Up messages	123
Table 11-2—Ethertype for Sync, Follow_Up, Pdelay_Req, Pdelay_Resp, and Pdelay_Resp_Follow_Up messages	123
Table 11-4—Values of flag bits	125
Table 11-3—Values for messageType field	125
Table 11-6—References for sequenceId value exceptions	126
Table 11-7—Value of control field	126
Table 11-5—Value of correction field	126
Table 11-8—Sync message fields	127
Table 11-9—Follow_Up message fields	127
Table 11-10—Follow_Up information TLV	128
Table 11-11—Pdelay_Req message fields	129
Table 11-12—Pdelay_Resp message fields	130
Table 11-13—Pdelay_Resp_Follow_Up message fields	130
Table 12-1—Parameters of MLME-TIMINGMSMT.request	139
Table 12-2—Parameters of MLME-TIMINGMSMT.confirm	140
Table 12-3—Parameters of MLME-TIMINGMSMT.indication	143
Table 12-4—Values of the Type field in the VendorSpecific information element	144
Table 13-1—TIMESYNC message fields	150
Table 14-1—Default Parameter Data Set Table	162
Table 14-2—Current Parameter Data Set Table	163
Table 14-3—Parent Parameter Data Set Table	165
Table 14-4—Time Properties Parameter Data Set Table	166
Table 14-5—portRole enumeration	167
Table 14-6—Port Parameter Data Set Table	170
Table 14-7—Port Parameter Statistics Table	173
Table 14-8—Acceptable Master Table Parameter Data Set Table	174
Table 15-1—IEEE8021-AS MIB structure and object cross reference	177
Table B.1—Wander generation TDEV requirement for LocalClock entity	246
Table B.2—ADEV limit corresponding to wander generation requirement of Table B.1	247
Table B.3—PTPDEV limit corresponding to wander generation requirement of Table B.1	248

Table B.4—Maximum endpoint filter bandwidths needed to meet respective MTIE masks and peak-to-peak jitter limits.....	250
Table B.5—Breakpoints for Mask 1.....	251
Table B.6—Breakpoints for Mask 2.....	251
Table B.7—Breakpoints for Mask 3.....	251
Table C.1—Time-scale parameters.....	253
Table C.2—Time-scale conversions.....	255
Table D.1—State machine symbols.....	258
Table E.1—CSN TLV.....	267
Table E.2—Definitions and option selections per link technology.....	268

IEEE Standard for Local and metropolitan area networks— Timing and Synchronization for Time-Sensitive Applications in Bridged Local Area Networks

IMPORTANT NOTICE: This standard is not intended to ensure safety, security, health, or environmental protection. Implementers of the standard are responsible for determining appropriate safety, security, environmental, and health practices or regulatory requirements.

This IEEE document is made available for use subject to important notices and legal disclaimers. These notices and disclaimers appear in all publications containing this document and may be found under the heading “Important Notice” or “Important Notices and Disclaimers Concerning IEEE Documents.” They can also be obtained on request from IEEE or viewed at <http://standards.ieee.org/IPR/disclaimers.html>.

1. Overview

1.1 Scope

This standard specifies the protocol and procedures used to ensure that the synchronization requirements are met for time-sensitive applications, such as audio and video, across bridged and virtual bridged local area networks consisting of local area network (LAN) media where the transmission delays are fixed and symmetrical; for example, IEEE 802.3™ full-duplex links. This includes the maintenance of synchronized time during normal operation and following addition, removal, or failure of network components and network reconfiguration. It specifies the use of IEEE 1588™ specifications where applicable in the context of IEEE Std 802.1D™-2004 and IEEE Std 802.1Q™-2005.¹ Synchronization to an externally provided timing signal (e.g., a recognized timing standard such as UTC or TAI) is not part of this standard but is not precluded.

1.2 Purpose

This standard enables stations attached to bridged LANs to meet the respective jitter, wander, and time synchronization requirements for time-sensitive applications. This includes applications that involve

¹Information on references can be found in Clause 2.

multiple streams delivered to multiple endpoints. To facilitate the widespread use of bridged LANs for these applications, synchronization information is one of the components needed at each network element where time-sensitive application data are mapped or demapped or a time-sensitive function is performed. This standard leverages the work of the IEEE 1588 Working Group by developing the additional specifications needed to address these requirements.

2. Normative references

The following referenced documents are indispensable for the application of this standard (i.e., they must be understood and used, so each referenced document is cited in text and its relationship to this document is explained). For dated references, only the edition cited applies. For undated references, the latest edition of the referenced document (including any amendments or corrigenda) applies.

IEEE P802.11vTM (D15.0, September 2010), Draft Standard for Information technology—Telecommunications and information exchange between systems—Local and metropolitan area networks—Specific requirements, Part 11: Wireless LAN Medium Access Control (MAC) and Physical Layer (PHY) Specifications—Amendment 8: IEEE 802.11TM Wireless Network Management.²

IEEE Std 802.1DTM-2004, IEEE Standard for Local and metropolitan area networks—Media Access Control (MAC) Bridges.^{3, 4}

IEEE Std 802.1QTM- 2005, IEEE Standard for Local and metropolitan area networks—Virtual Bridged Local Area Networks.

IEEE Std 802.1agTM-2007, IEEE Standard for Local and metropolitan area networks—Virtual Bridged Local Area Networks—Amendment 5: Connectivity Fault Management.

IEEE Std 802.3TM-2008, IEEE Standard for Information technology—Telecommunications and information exchange between systems—Local and metropolitan area network—Specific requirements, Part 3: Carrier sense multiple access with collision detection (CSMA/CD) access method and physical layer specifications.

IEEE Std 802.3avTM-2009, IEEE Standard for Information technology—Part 3: Amendment 1: Physical Layer Specifications and Management Parameters for 10 Gb/s Passive Optical Networks.

IEEE Std 802.11TM-2007, IEEE Standard for Information technology—Telecommunications and information exchange between systems—Local and metropolitan area networks—Specific requirements, Part 11: Wireless LAN Medium Access Control (MAC) and Physical Layer (PHY) Specifications.

IEEE Std 1588TM-2008, IEEE Standard for a Precision Clock Synchronization Protocol for Networked Measurement and Control Systems.

IETF RFC 3410 (December 2002), Introduction and Applicability Statements for Internet Standard Management Framework, Case, J., Mundy, R., Partain, D, and Stewart, B.⁵

ITU-T Recommendation G.9960 (ex. G.hn), Unified high-speed wire-line based home networking transceivers—System architecture and physical layer specification, June 2010.⁶

ITU-T Recommendation G.9961, Data link layer (DLL) for unified high-speed wire-line based home networking transceivers, June 2010.

²IEEE P802.11v/D16 (November 2010) was approved by the IEEE-SA Standards Board on 2 February 2011. It was published as IEEE Std 802.11v-2011 on 9 February 2011 and is available from the Institute of Electrical and Electronics Engineers, 445 Hoes Lane, Piscataway, NJ 08854, USA (<http://standards.ieee.org>).

³IEEE publications are available from the Institute of Electrical and Electronics Engineers, 445 Hoes Lane, Piscataway, NJ 08854, USA (<http://standards.ieee.org>).

⁴The IEEE standards or products referred to in Clause 2 are trademarks owned by the Institute of Electrical and Electronics Engineers, Incorporated.

⁵IETF RFCs are available from the Internet Engineering Task Force Web site at <http://www.ietf.org/rfc.html>.

⁶ITU-T publications are available from the International Telecommunications Union, Place des Nations, CH-1211, Geneva 20, Switzerland/Suisse (<http://www.itu.int/>).

ITU-T Recommendation G.984.3, Amendment 2 (2009-11) Gigabit-capable Passive Optical Networks (G-PON): Transmission convergence layer specification—Time-of-day distribution and maintenance updates and clarifications, November 2009.

MoCA[®] MAC/PHY Specification v2.0, MoCA-M/P-SPEC-V2.0-20100507, Multimedia over Coax Alliance (MoCA).⁷

⁷MoCA specifications are available from the Multimedia over Coax Alliance at <http://www.mocalliance.org/specs>.

3. Definitions

For the purposes of this document, the following terms and definitions apply. *The IEEE Standards Dictionary: Glossary of Terms & Definitions* should be consulted for terms not defined in this clause.⁸

3.1 accuracy: The mean of the time or frequency error between the clock under test and a perfect reference clock over an ensemble of measurements.

3.2 Bridge: Either a MAC Bridge, as specified in Clause 5 of IEEE Std 802.1D-2004, or a VLAN-aware Bridge, as specified in Clause 5 of IEEE Std 802.1Q-2005.

3.3 clock: A physical device that is capable of providing a measurement of the passage of time since a defined epoch.

3.4 direct communication: A communication of IEEE 802.1AS information between two time-aware systems with no intervening time-aware system.

3.5 end station: A device attached to a local area network (LAN) or metropolitan area network (MAN), which acts as a source of, and/or destination for, traffic carried on the LAN or MAN.

NOTE—In this standard, an *end station* is sometimes referred to as a *station*.⁹

3.6 event message: A message that is timestamped on egress from a time-aware system and ingress to a time-aware system.

NOTE—See 8.4.3.

3.7 fractional frequency offset: The fractional frequency offset, y , between a measured clock and a reference clock is defined as:

$$y = \frac{f_m - f_r}{f_r}$$

where f_m is the frequency of the measured clock and f_r is the frequency of the reference clock. The measurement units of f_m and f_r are the same.

3.8 general message: A message that is not timestamped.

3.9 gPTP communication path: A segment of a generalized precision time protocol (gPTP) domain that enables direct communication between two time-aware systems.

NOTE—See 8.1.

3.10 grandmaster: The time-aware system that contains the best clock, as determined by the best master clock algorithm (BMCA), in the generalized precision time protocol (gPTP) domain.

3.11 message timestamp point: A point within an event message serving as a reference point for when a timestamp is taken.

3.12 message type: The message type of a message is the name of the respective message, e.g., Sync, Announce, Timing Measurement Action Frame.

⁸The *IEEE Standards Dictionary: Glossary of Terms & Definitions* is available at <http://shop.ieee.org/>.

⁹Notes in text, tables, and figures of a standard are given for information only and do not contain requirements needed to implement this standard.

3.13 precision: A measure of the deviation from the mean of the time or frequency error between the clock under test and a perfect reference clock.

3.14 primary reference: A source of time and/or frequency that is traceable to international standards. *See also: traceability.*

3.15 recognized standard source of time: A recognized standard time source is a source external to IEEE 1588 precision time protocol (PTP) that provides time that is traceable to the international standards laboratories maintaining clocks that form the basis for the *temps atomique international* (international atomic time) (TAI) and coordinated universal time (UTC) timescales. Examples of these are National Institute of Standards and Technology (NIST) timeservers and global positioning (satellite) system (GPS).

3.16 reference plane: The boundary between a port of a time-aware system and the network physical medium. Timestamp events occur as frames cross this interface.

3.17 residence time: The duration of the time interval between the receipt of a time synchronization event message by a time-aware system, and the sending of the next subsequent time synchronization event message on another port of that time-aware system. The residence time can be different for different ports.

NOTE—If a port of a time-aware system sends a time synchronization event message without having received a time synchronization event message, i.e., if sync receipt timeout occurs (see 10.6.3.1), the duration of the interval between the most recently received time synchronization event message and the sent time synchronization event message is mathematically equivalent to residence time; however, this interval is not normally referred to as a *residence time*.

3.18 stability: A measure of how the mean of the time or frequency error between the clock under test and a perfect reference clock varies with respect to variables such as time, temperature, etc.

3.19 synchronized time: The synchronized time of an event is the time of that event relative to the grandmaster.

NOTE—If there is a change in the grandmaster or grandmaster time base, the *synchronized time* can experience a phase and/or frequency step.

3.20 synchronized time-aware systems: Two time-aware systems are synchronized to a specified uncertainty if they have the same epoch and their measurements of the time of a single event at an arbitrary time differ by no more than that uncertainty.

NOTE—See 8.2.2.

3.21 syntonized time-aware systems: Two time-aware systems are syntonized if the duration of the second is the same on both, which means the time measured by each advances at the same rate. They can but need not share the same epoch.

3.22 time-aware Bridge: A Bridge that is capable of communicating synchronized time received on one port to other ports, using the IEEE 802.1AS protocol.

3.23 time-aware end station: An end station that is capable of acting as the source of synchronized time on the network, or destination of synchronized time using the IEEE 802.1AS protocol, or both.

3.24 time-aware system: A time-aware Bridge or a time-aware end station.

3.25 timestamp measurement plane: The plane at which timestamps are captured. If the timestamp measurement plane is different from the reference plane, the timestamp is corrected for ingressLatency and/or egressLatency. *See:* **reference plane.**

NOTE—For timestamp on egress and ingress, see 8.4.3.

3.26 traceability: See IEEE Std 1588-2008, 3.1.44.

4. Acronyms and abbreviations

ACK	acknowledgement
ADEV	Allan deviation
AP	(wireless LAN) access point
AV	audio/video
AVB	audio/video bridging
AVB network	audio/video bridged network
BC	boundary clock
BMC	best master clock
BMCA	best master clock algorithm
CSN	coordinated shared network
CTC	channel time clock
EPON	IEEE 802.3 Ethernet passive optical network, as specified in IEEE Std 802.3-2008 and IEEE Std 802.3av-2009
ESS	extended service set
G.hn	ITU-T G.9960 and ITU-T G.9961
GM	grandmaster
GMT	Greenwich mean time
GPS	global positioning (satellite) system
gPTP	generalized precision time protocol
IP	Internet protocol
IS	integration service
ISO	International Organization for Standardization ¹⁰
ISS	Internal Sublayer Service
LAN	local area network
LLC	logical link control
MAC	media access control
MACsec	media access control security
MAN	metropolitan area network
MLME	IEEE 802.11 MAC layer management entity
MPCP	IEEE 802.3 multipoint control protocol
MPDPDU	IEEE 802.3 MPCP data unit
MII	media-independent interface
MD	media-dependent

¹⁰Information available at www.iso.org.

NTP	network time protocol ¹¹
OC	ordinary clock
OLT	IEEE 802.3 optical line terminal
ONU	IEEE 802.3 optical network unit
OSSP	organization-specific slow protocol
P2P	peer-to-peer
PAR	project authorization request
PICS	Protocol Implementation Conformance Statement
PLL	phased-lock loop
POSIX™	portable operating system interface (see ISO/IEC 9945:2003 [B10] ¹²)
PTP	IEEE 1588 precision time protocol
PTPDEV	PTP deviation
RTT	round-trip time
SI	international system of units
SM	state machine
TAI	temps atomique international (international atomic time)
TC	transparent clock
TDEV	time deviation
TDM	time division multiplexing
TDMA	time division multiple access
TG	task group
TS	timestamp
UCT	unconditional transfer
UTC	coordinated universal time
VLAN	virtual local area network
WG	Working Group
WLAN	wireless local area network

¹¹Information available at www.ietf.org/rfc/rfc1305.txt.

¹²The numbers in brackets correspond to those of the bibliography in Annex G.

5. Conformance

This clause specifies the mandatory and optional capabilities provided by conformant implementations of this standard. An implementation can:

- a) Compose all or part of the functionality of a system;
- b) Provide, as specified by this standard, one or more instances of the MAC Service to other functional entities whose specification is outside the scope of this standard;
- c) Provide, as specified by this standard, one or more instances of the MAC Internal Sublayer Service (ISS) to other implementations or instances of the same implementation that conform to this standard.

Accordingly, and as detailed in 5.3, this clause specifies conformance requirements for common systems and for functional components within systems, possibly connected to other system components with interfaces that are not otherwise accessible.

5.1 Requirements terminology

For consistency with existing IEEE and IEEE 802.1 standards, requirements placed upon conformant implementations of this standard are expressed using the following terminology:

- a) **shall** is used for mandatory requirements;
- b) **may** is used to describe implementation or administrative choices (“may” means “is permitted to,” and hence, “may” and “may not” mean precisely the same thing);
- c) **should** is used for recommended choices (the behaviors described by “should” and “should not” are both permissible but not equally desirable choices).

The Protocol Implementation Conformance Statement (PICS) proforma (see Annex A) reflects the occurrences of the words shall, may, and should within the standard.

The standard avoids needless repetition and apparent duplication of its formal requirements by using **is**, **is not**, **are**, and **are not** for definitions and the logical consequences of conformant behavior. Behavior that is permitted but is neither always required nor directly controlled by an implementer or administrator, or whose conformance requirement is detailed elsewhere, is described by **can**. Behavior that never occurs in a conformant implementation or system of conformant implementations is described by **can not**. The word **allow** is used as a replacement for the cliché “support the ability for,” and the word **capability** means “can be configured to.”

5.2 Protocol Implementation Conformance Statement (PICS)

The supplier of an implementation that is claimed to conform to this standard shall complete a copy of the PICS proforma provided in Annex A and shall provide the information necessary to identify both the supplier and the implementation.

5.3 Time-aware Bridge and end station requirements

An implementation of timing and synchronization in Bridges shall:

- a) Conform to the requirements of IEEE Std 802.1Q-2005;
- b) Implement the generalized precision time protocol (gPTP) requirements specified in 8.2, 8.4, 8.5, and 8.6;

- c) Support the media-independent slave clock at least on one port (10.2.12), and on each supported port, implement PortSyncSyncReceive function (10.2.7.3) and ClockSlaveSync function (10.2.12.3);
- d) Support the requirements where no best master is present in the domain (10.2.12.2);
- e) Support the following best master clock algorithm (BMCA) requirements (10.3):
 - 1) Support the Time-aware system attributes and requirements (8.6.2);
 - 2) Implement the BMCA (10.3.2);
 - 3) Implement PortAnnounceReceive function (10.3.10);
 - 4) Implement PortAnnounceInformation function (10.3.11);
 - 5) Implement PortRoleSelection function (10.3.12).
- f) Implement SiteSyncSync function (10.2.6).

5.3.1 Time-aware Bridge and end station options

An implementation of Time-aware Bridge may:

- a) Support the following Grandmaster Capability (8.6.2.1 and 10.1.2):
 - 1) Implement ClockMasterSyncSend function (10.2.8);
 - 2) Implement ClockMasterSyncOffset function (10.2.9);
 - 3) Implement ClockMasterReceive function (10.2.10).
- b) Support the media-independent slave clock on more than one port (10.2.6);
- c) Support the following Media Independent Master Capability on at least one port (10.2.11):
 - 1) Implement PortSyncSyncSend function (10.2.11);
 - 2) Implement PortAnnounceTransmit function (10.3.13);
 - 3) Implement AnnounceIntervalSetting function (10.3.14);
 - 4) Conform to Announce message requirements (10.4.3);
 - 5) Support the Announce sequence number requirements (10.4.7);
 - 6) Support the Announce message PDU requirements (10.5).

5.4 MAC-specific timing and synchronization methods for IEEE 802.3 full-duplex links

An implementation of Time-aware Bridges with IEEE 802.3 MAC services to physical ports shall:

- a) Conform to the requirements of IEEE 802.1Q MAC-specific bridging methods;
- b) Support full-duplex operation, as specified in 11.2 and IEEE Std 802.3-2008, 4.2 and Annex 4.

5.5 MAC-specific timing and synchronization methods for IEEE Std 802.11-2007

An implementation of Time-aware Bridges with IEEE 802.11 MAC services to physical ports shall:

- a) Conform to the requirements of IEEE 802.1Q MAC-specific bridging methods;
- b) Conform to the requirements of TIMINGMSMT as specified in IEEE P802.11v (D15.0, September 2010);
- c) Support the requirements as specified in 12.2;
- d) Implement MDSync Message protocol, its message parameters and defaults (12.3).

5.6 MAC-specific timing and synchronization methods for IEEE 802.3 EPON

An implementation of Timing-aware Bridges with IEEE 802.3 EPON MAC services to physical ports shall:

- a) Conform to the requirements of IEEE 802.1Q MAC-specific bridging methods;

- b) Support the requirements as specified in IEEE Std 802.3-2008, Multipoint MAC Control (64.2 and 64.3) and Multipoint PCS and PMA extensions (65);
- c) Implement TIMESYNC Message protocol, and its message parameters and defaults (13.3.1);
- d) Implement requester and responder functions (13.8.1 and 13.8.2).

5.7 MAC-specific timing and synchronization methods for coordinated shared network (CSN)

An implementation of Timing-aware Bridges with CSN MAC services to physical ports shall:

- a) Conform to the requirements of IEEE 802.1Q MAC-specific bridging methods;
- b) Implement path delay calculation, as specified in E.4;
- c) Implement functionality of MDSyncSendSM and MDSyncReceiveSM state machines (E.3);
- d) Implement CSN specific Grandmaster Capability (E.6.1).

6. Conventions

6.1 General

This clause defines various conventions and notation used in the standard, i.e., naming conventions, service specification method and notation, and data type definitions.

6.2 Service specification method and notation

The method and notation for specifying service interfaces is described in 6.1 of IEEE Std 802.1ag-2007.

6.3 Data types and on-the-wire formats

6.3.1 General

The data types specified for the various variables and message fields define logical properties that are necessary for correct operation of the protocol or interpretation of IEEE 1588 precision time protocol (PTP) or IEEE P802.11v message content.

NOTE—Implementations are free to use any internal representation of data types if the internal representation does not change the semantics of any quantity visible via communications using the IEEE 802.1AS protocol or in the specified operations of the protocol.

6.3.2 Primitive data types specifications

All non-primitive data types are derived from the primitive types in Table 6-1. Signed integers are represented in two's complement form.

Table 6-1—Primitive data types

Data type	Definition
Boolean	TRUE or FALSE
EnumerationN	N-bit enumerated value
UIntegerN	N-bit unsigned integer
IntegerN	N-bit signed integer
Nibble	4-bit field not interpreted as a number
Octet	8-bit field not interpreted as a number
OctetN	N-octet field not interpreted as a number, with $N > 1$
Double	Double precision (64-bit) floating-point value

6.3.3 Derived data type specifications

6.3.3.1 ScaledNs

The ScaledNs type represents signed values of time and time interval in units of 2^{-16} ns.

```
typedef Integer96 ScaledNs;
```

For example: -2.5 ns is expressed as:

```
0xFFFF FFFF FFFF FFFF FFFD 8000
```

Positive or negative values of time or time interval outside the maximum range of this data type are encoded as the largest positive or negative value of the data type, respectively.

6.3.3.2 UScaledNs

The UScaledNs type represents unsigned values of time and time interval in units of 2^{-16} ns.

```
typedef UInteger96 UScaledNs;
```

For example: 2.5 ns is expressed as:

```
0x0000 0000 0000 0000 0002 8000
```

Values of time or time interval greater than the maximum value of this data type are encoded as the largest positive value of the data type, respectively.

6.3.3.3 TimeInterval

The TimeInterval type represents time intervals, in units of 2^{-16} ns.

```
struct TimeInterval  
{  
    Integer64 scaledNanoseconds;  
};
```

For example: 2.5 ns is expressed as:

```
0x0000 0000 0002 8000
```

Positive or negative time intervals outside the maximum range of this data type are encoded as the largest positive and negative values of the data type, respectively.

6.3.3.4 Timestamp

The Timestamp type represents a positive time with respect to the epoch.

```
struct Timestamp  
{  
    UInteger48 seconds;  
    UInteger32 nanoseconds;  
};
```

The seconds member is the integer portion of the timestamp in units of seconds.

The nanoseconds member is the fractional portion of the timestamp in units of nanoseconds.

The nanoseconds member is always less than 10^9 .

For example:

+2.000000001 seconds is represented by seconds = 0x0000 0000 0002 and nanoseconds= 0x0000 0001

6.3.3.5 ExtendedTimestamp

The ExtendTimestamp type represents a positive time with respect to the epoch.

```
struct ExtendedTimestamp
{
    UInteger48 seconds;
    UInteger48 fractionalNanoseconds;
};
```

The seconds member is the integer portion of the timestamp in units of seconds.

The fractionalNanoseconds member is the fractional portion of the timestamp in units of 2^{-16} ns.

The fractionalNanoseconds member is always less than $(2^{16})(10^9)$.

For example:

+2.000000001 seconds is represented by seconds = 0x0000 0000 0002 and nanoseconds = 0x0000 0001 0000

6.3.3.6 ClockIdentity

The ClockIdentity type identifies a time-aware system.

```
typedef Octet8 ClockIdentity;
```

6.3.3.7 PortIdentity

The PortIdentity type identifies a port of a time-aware system.

```
struct PortIdentity
{
    ClockIdentity clockIdentity;
    UInteger16 portNumber;
};
```

6.3.3.8 ClockQuality

The ClockQuality represents the quality of a clock.

```
struct ClockQuality
{
    UInteger8 clockClass;
    Enumeration8 clockAccuracy;
    UInteger16 offsetScaledLogVariance;
};
```

6.3.4 Protocol data unit (PDU) formats

6.3.4.1 General

The data types defined in 6.3.2 and 6.3.3 shall be mapped onto the wire according to the mapping rules for the respective medium, e.g., IEEE Std 802.3-2008 and IEEE Std 802.11-2007, and the terms of 6.3.4.

IEEE 802.1AS PDUs consist of the messages defined or referenced in Clause 10, Clause 11, Clause 12, and Clause 13, based on the data types defined in 6.3.2 and 6.3.3. The internal ordering of the fields of the IEEE 802.1AS PDUs is specified in 6.3.4.3 to 6.3.4.5.

6.3.4.2 Numbering of bits within an octet

Bits are numbered with the most significant bit being 8 and the least significant bit being 1.

NOTE—The numbering and ordering of bits within an octet of a PDU, described here, is independent of and unrelated to the order of transmission of the bits on the underlying physical layer.

6.3.4.3 Primitive data types

Numeric primitive data types defined in 6.3.2 shall be formatted with the most significant octet nearest the beginning of the PDU followed in order by octets of decreasing significance.

The Boolean data type TRUE shall be formatted as a single bit equal to 1 and FALSE as a single bit equal to 0.

Enumerations of whatever length shall be formatted as though the assigned values are unsigned integers of the same length, e.g., Enumeration16 shall be formatted as though the value had type UInteger16.

6.3.4.4 Arrays of primitive types

All arrays shall be formatted with the member having the lowest numerical index closest to the start of the PDU followed by successively higher numbered members, without any padding. In octet arrays, the octet with the lowest numerical index is termed the most significant octet.

When a field containing more than one octet is used to represent a numeric value, the most significant octet shall be nearest the start of the PDU, followed by successively less significant octets.

When a single octet contains multiple fields of primitive data types, the bit positions within the octet of each of the primitive types as defined in the message field specification shall be preserved. For example, the first field of the header of PTP messages is a single octet composed of two fields, one of type Nibble bits 5–8, and one of type Enumeration4 bits 1–4, see 11.4.2 and 10.5.2.

6.3.4.5 Derived data types

Derived data types defined as structs shall be formatted with the first member of the struct closest to the beginning of the PDU followed by each succeeding member, without any padding. Each member shall be formatted according to its data type.

Derived data types defined as typedefs shall be formatted according to its referenced data type.

7. Time synchronization model for a bridged local area network

7.1 General

This clause provides a model for understanding the operation of the generalized precision time protocol (gPTP), which specifies the operation of time-aware systems on a bridged packet-switched LAN. Although this standard is based on the precision time protocol (PTP) described in IEEE Std 1588-2008 (and, indeed, is a proper profile of IEEE Std 1588 in particular configurations) there are differences, which are summarized in 7.5.

Although this standard has been written as a stand-alone document, it is useful to understand the IEEE 1588 architecture as described in Clause 6 of that document.

7.2 Architecture of a time-aware bridged local area network

A time-aware bridged LAN consists of a number of time-aware systems interconnected by LANs that support the gPTP defined within this standard. A set of time-aware systems that are interconnected by gPTP-capable LANs is called a *gPTP domain*. There are two types of time-aware systems, as follows:

- a) Time-aware end station, which if not grandmaster, is a recipient of time information, and
- b) Time-aware Bridge, which if not grandmaster, receives time information from the grandmaster (perhaps indirectly through other time-aware Bridges), applies corrections to compensate for delays in the LAN and the Bridge itself, and retransmits the corrected information.

This standard defines mechanisms for delay measurements using standard-based procedures for the following:

- c) IEEE 802.3 Ethernet using full-duplex point-to-point links (Clause 11)
- d) IEEE 802.3 Ethernet using passive optical network (EPON) links (Clause 13)
- e) IEEE 802.11 wireless (Clause 12)
- f) Generic coordinated shared networks (CSNs, e.g., MoCA and G.hn) (Annex E)

Figure 7-1 illustrates an example time-aware network using all those network technologies, where end stations on several local networks are connected to a grandmaster on a backbone network via an EPON access network.

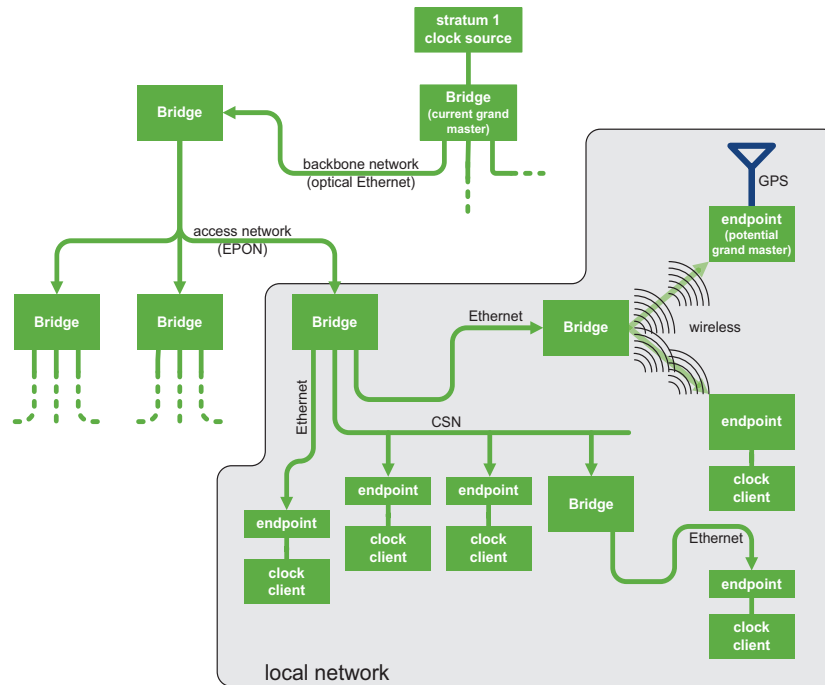

Figure 7-1—Time-aware network example

Any time-aware system with clock sourcing capabilities can be a potential grandmaster, so there is a selection method (the *best master clock algorithm*, or BMCA) that ensures that all of the time-aware systems in a gPTP domain use the same grandmaster.¹³ The BMCA is largely identical to that used in IEEE Std 1588-2008, but somewhat simplified. In Figure 7-1 the BMCA process has resulted in the grandmaster being on the network backbone. If, however, the access network fails, the systems on a local network automatically switch over to one of the potential grandmasters on the local network that is as least as “good” as any other. For example, in Figure 7-2, the access network link has failed, so a potential grandmaster that has a GPS reference source has become the active grandmaster, and there are now two gPTP domains where there used to be one.

¹³ There are, however, short periods during network reconfiguration when more than one grandmaster might be active while the BMCA process is taking place.

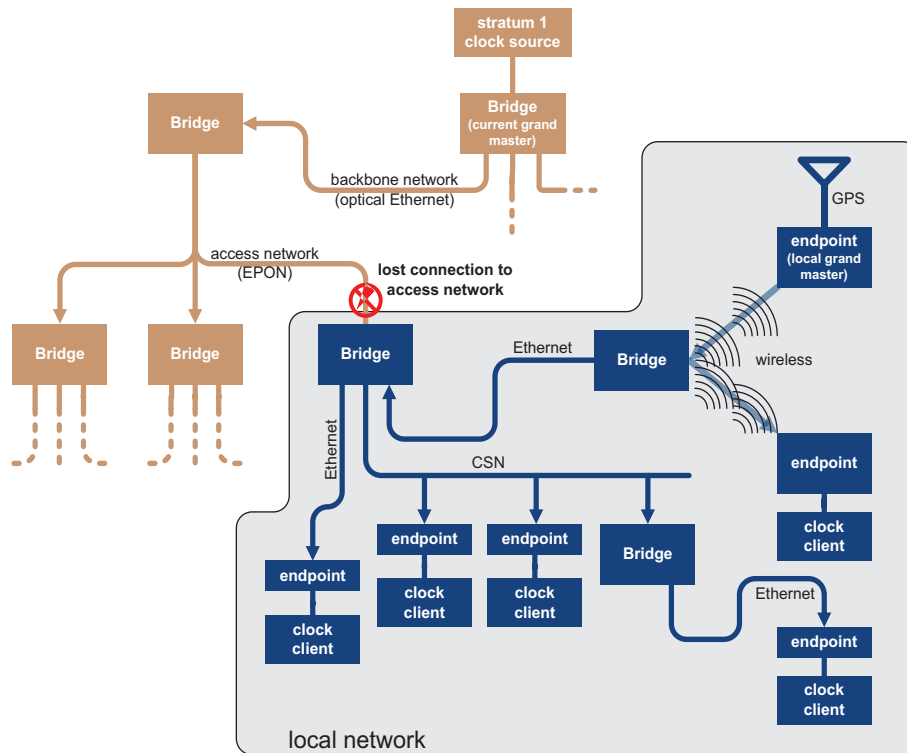

Figure 7-2—Time-aware network of Figure 7-1 after an access network link failure

7.3 Time synchronization

7.3.1 General

Time synchronization in gPTP is done the same way (in the abstract) as is done in IEEE Std 1588-2008: a grandmaster sends information including the current synchronized time to all directly attached time-aware systems. Each of these time-aware systems must correct the received synchronized time by adding the propagation time needed for the information to transit the communication path from the grandmaster. If the time-aware system is a time-aware Bridge, then it must forward the corrected time information (including additional corrections for delays in the forwarding process) to all the other attached time-aware systems.

To make this all work, there are two time intervals that must be precisely known: the forwarding delay (called the *residence time*), and the time taken for the synchronized time information to transit the communication path between two time-aware systems. The residence time measurement is local to a Bridge and easy to compute, while the communication path delay is dependent on many things including media-dependent properties and the length of the path.

7.3.2 Delay measurement

Each type of LAN or communication path has different methods for measuring propagation time, but they are all based on the same principal: measuring the time that a well-known part of a message is transmitted from one device and the time that the same part of the same message is received by the other device, then sending another message in the opposite direction and doing the same measurement as shown in Figure 7-3.

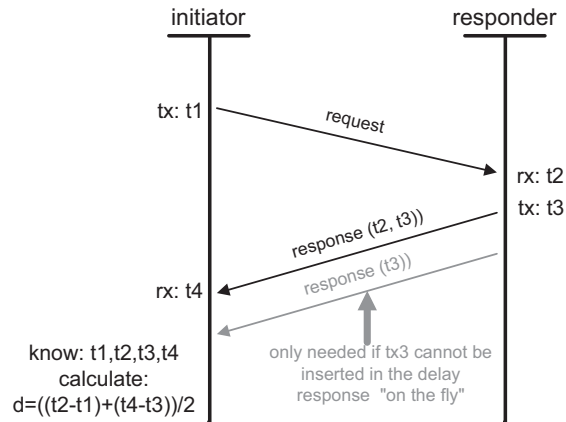

Figure 7-3— Example delay measurement

This basic mechanism is used in the various LANs in the following ways:

- a) Full-duplex Ethernet LANs use the two step peer-to-peer (P2P) path delay algorithm as defined in IEEE Std 1588-2008, where the messages are called Pdelay_Req, Pdelay_Resp, and Pdelay_Resp_Follow_Up.
- a) IEEE 802.11 wireless LANs use the Timing measurement procedure defined in IEEE P802.11v (D15.0, September 2010), where the messages are the “timing measurement action frame” and its corresponding “ACK.”
- a) EPON LANs use the discovery process, where the messages are “GATE” and “REGISTER_REQ.”
- a) CSNs either use the same mechanism as full-duplex Ethernet, or use a method native to the particular CSN (similar to the way native methods are used by IEEE 802.11 and EPON).

7.3.3 Logical syntonization

The time synchronization correction previously described is dependent on the accuracy of the delay and residence time measurements. If the clock used for this purpose is frequency locked (syntonized) to the grandmaster, then all the time interval measurements use the same time base. Since actually adjusting the frequency of an oscillator (e.g., using a PLL) is slow and prone to gain peaking effects, time-aware Bridges can correct time interval measurements using the grandmaster frequency ratio.

Each time-aware system measures, at each port, the ratio of the frequency of the time-aware system at the other end of the link attached to that port to the frequency of its own clock. The cumulative ratio of the grandmaster frequency to the local clock frequency is accumulated in a standard organizational type, length, value (TLV) attached to the Follow_Up message. The frequency ratio of the grandmaster relative to the local clock is used in computing synchronized time, and the frequency ratio of the neighbor relative to the local clock is used in correcting the propagation time measurement.

The grandmaster frequency ratio is measured by accumulating neighbor frequency ratios for two main reasons. First, if there is a network reconfiguration and a new grandmaster is elected, the nearest neighbor frequency ratios do not have to be newly measured as they are constantly measured using the Pdelay messages. This results in the frequency offset relative to the new grandmaster being known when the first Follow_Up message is received, which reduces the duration of any transient in synchronized time during the reconfiguration. This is beneficial to many high-end audio applications. Second, there are no gain peaking

effects because an error in frequency offset at one node, and resulting residence time error, does not directly affect the frequency offset at a downstream node.

7.3.4 Grandmaster (best master) selection and network establishment

All time-aware systems participate in best master selection so that the IEEE 802.1AS protocol can determine the synchronization spanning tree. This synchronization spanning tree may be different from the forwarding spanning tree determined by IEEE 802.1D and IEEE 802.1Q Rapid Spanning Tree Protocol (RSTP) since the spanning tree determined by RSTP can be suboptimal, or even inadequate for synchronization.

gPTP requires that all Bridges and end-stations in the gPTP domain be time-aware-systems, i.e., the protocol does not transfer timing over “ordinary Bridges” (those that meet the requirements of IEEE Std 802.1D-2004 or IEEE Std 802.1Q-2005, but do NOT meet the requirements of this standard). A time-aware system uses the peer delay mechanism on each port to determine if an “ordinary Bridge” is at the other end of the link or in between itself and the Pdelay responder. If, on sending Pdelay_Req

- a) no response is received,
- b) multiple responses are received, or
- c) the measured propagation delay exceeds a specified threshold, then

the protocol concludes that an “ordinary Bridge” or end-to-end TC (see IEEE Std 1588-2008) is present. In this case, the link attached to the port is deemed not capable of running gPTP, and BMCA ignores it. However, the port continues to attempt the measurement of propagation delay using the peer delay mechanism (for full-duplex IEEE 802.3 links), MPCP messages (for EPON), or IEEE P802.11v messages (for IEEE 802.11 links), and periodically checks whether the link is or is not capable of running IEEE 802.1AS.

7.3.5 Energy efficiency

Sending PTP messages at relatively high rates when there is otherwise little or no traffic is counter to the goal of reducing energy consumption. This standard specifies a way to request that a neighbor port reduce the rate of sending Sync (and Follow_Up), peer delay, and Announce messages, and also to inform the neighbor not to compute neighbor rate ratio and/or propagation delay on this link. A time-aware system could do this when it enters low-power mode, but this standard does not specify the conditions under which this is done; it specifies only the actions a time-aware system takes.

7.4 Time-aware system architecture

The model of a time-aware system is shown in Figure 7-4.

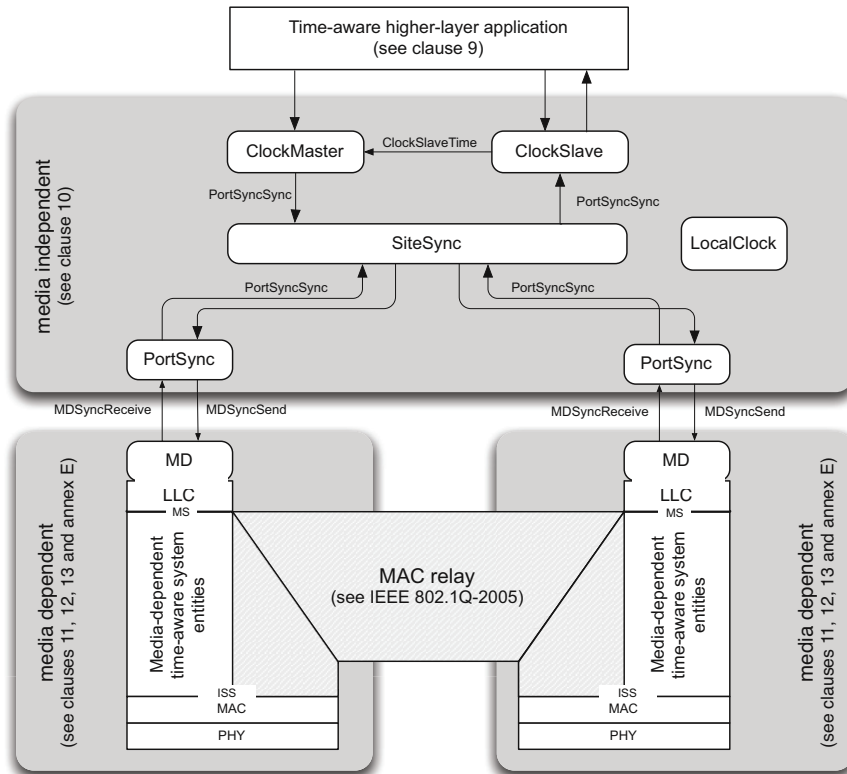

Figure 7-4—Time-aware system model

A time-aware system consists of the following major parts:

- a) If the time-aware system includes application(s) that either use or source time information, then they interface with the gPTP information using the application interfaces specified in Clause 9.
- b) A single media-independent part that consists of ClockMaster, ClockSlave, and SiteSync logical entities, one or more PortSync entities, and a LocalClock entity. The BMCA and forwarding of time information between logical ports and the ClockSlave and ClockMaster is done by the SiteSync entity, while the computation of port-specific delays needed for time synchronization correction is done by the PortSync entities.
- c) Media-dependent ports, which translate the abstract “MDSyncSend” and “MDSyncReceive” structures received from or sent to the media-independent layer and corresponding methods used for the particular LAN attached to the port.

In the case of full-duplex Ethernet ports, IEEE 1588 Sync and Follow_Up messages are used, with an additional TLV in the Follow_up used for communication of rate ratio and information on phase and frequency change when there is a change in grandmaster. The path delay is measured using the two-step IEEE 1588 peer delay mechanism. This is defined in Clause 11.

For IEEE 802.11 ports, timing information is communicated using the MAC Layer Management Entity to request a “timing measurement” [as defined in IEEE P802.11v (D15.0, September 2010)], which also sends everything that would be included in the Follow_up message for full-duplex Ethernet. The timing measurement result includes all the information to determine the path delay. This is defined in Clause 12.

For EPON, timing information is communicated using a “slow protocol” as defined in Clause 13. CSNs use the same communication system used by Ethernet full-duplex, as is defined in Annex E.

7.5 Differences between gPTP and PTP

- a) gPTP assumes all communication between time-aware systems is done only using IEEE 802 MAC PDUs and addressing, while IEEE 1588 supports various layer 2 and layer 3-4 communication methods.
- b) gPTP specifies a media-independent sublayer that simplifies the integration within a single timing domain of multiple different networking technologies with radically different media access protocols. The information exchanged between time-aware systems has been generalized to support different packet formats and management schemes appropriate to the particular networking technology. IEEE 1588, on the other hand, is fully specified only for IP version 4, IP version 6, Ethernet LANs, and several industrial automation control protocols.
- c) In gPTP there are only two types of time-aware systems: end stations and Bridges, while IEEE 1588 has ordinary clocks, boundary clocks, end-to-end transparent clocks, and P2P transparent clocks. A time-aware end station corresponds to an IEEE 1588 ordinary clock, and a time-aware Bridge is a type of IEEE 1588 boundary clock where its operation is very tightly defined, so much so that a time-aware Bridge with Ethernet ports can be shown to be mathematically equivalent to a P2P transparent clock in terms of how synchronization is performed, as shown in 11.1.3. A time-aware system measures link delay and residence time, and communicates these in a correction field.
- d) Time-aware systems only communicate gPTP information directly with other time-aware systems. That is, a gPTP domain consists ONLY of time-aware systems. Non-time-aware Bridges cannot be used to relay gPTP information. In IEEE 1588 it is possible to use non-IEEE-1588-aware Bridges in an IEEE 1588 domain, although this slows timing convergence and introduce extra jitter and wander that must be filtered by any IEEE 1588 clock.
- e) For Ethernet full-duplex links, gPTP requires the use of the peer delay mechanism, while IEEE 1588 also allows the use of end-to-end delay measurement.
- f) For Ethernet full-duplex links, gPTP requires the use of two-step processing (use of Follow_Up and Pdelay_Resp_Follow_Up messages to communicate timestamps), while IEEE 1588 allows one-step processing (embedding timestamps in messages “on the fly” as they are being transmitted).
- g) In steady state, there is only a single active grandmaster in a time-aware network. That is, there is only a single gPTP domain, whereas IEEE 1588 allows multiple overlapping timing domains.
- h) All time-aware systems in a gPTP domain are logically syntonized, meaning that they all measure time intervals using the same frequency. This is done by the process described in 7.3.3, and is mandatory. Syntonization in IEEE 1588 is optional, and the method used is not as direct and takes longer to converge.
- i) The BMCA used in gPTP is the same as that used in IEEE 1588 with the following exceptions: (1) Announce messages received on a slave port that were not sent by the receiving time-aware system are used immediately, i.e., there is no foreign-master qualification, (2) a port that the BMCA determines should be a master port enters the master state immediately, i.e., there is no pre-master state, (3) the uncalibrated state is not needed and, therefore, not used, and (4) all time-aware systems are required to participate in best master selection (even if it is not grandmaster capable).
- j) Finally, this standard includes formal interface definitions for the time-aware applications. (See Clause 9.) IEEE Std 1588-2008 does not define how an application provides or obtains time information.

8. IEEE 802.1AS concepts and terminology

8.1 gPTP domain

A gPTP domain, hereafter referred to as simply a *domain*, consists of one or more time-aware systems and links that meet the requirements of this standard and communicate with each other as defined by the IEEE 802.1AS protocol. A gPTP domain defines the scope of gPTP message communication, state, operations, data sets, and timescale.

The domain number of a gPTP domain shall be 0.

NOTE—In steady state, all time-aware systems in a gPTP domain are traceable to a single grandmaster.

8.2 Timescale

8.2.1 Introduction

The timescale for a gPTP domain, referred to as the *PTP timescale*, is established by the grandmaster. The IEEE 802.1AS timescale is continuous and can be traceable to TAI. The value of the second is the international second, SI, within the accuracy supported by the gPTP domain. The epoch is the PTP epoch (see 8.2.2).

8.2.2 Epoch

The epoch is the origin of the timescale of a gPTP domain.

The PTP epoch is 1 January 1970 00:00:00 TAI, which is 31 December 1969 23:59:51.999918 UTC.

NOTE—The PTP epoch is set such that a direct application of the POSIX algorithm to a PTP time-scale timestamp yields the ISO 8601:2004 [B8] printed representation of TAI.

See Annex C for information on converting between common timescales.

8.2.3 UTC Offset

It is possible to calculate UTC time using the `currentUtcOffset` field value of the time properties data set, if the time source is traceable to TAI and the `currentUtcOffset` field is valid. The value of `currentUtcOffset` shall be: $\text{currentUtcOffset} = \text{TAI} - \text{UTC}$, where TAI is the TAI time and UTC is the UTC time.

NOTE—As of 0 hours 1 January 2009 UTC, UTC was behind TAI by 34 s, i.e., $\text{TAI} - \text{UTC} = +34$ s. At that moment the IEEE 802.1AS defined value of `currentUtcOffset` became +34 s (see *Service de la Rotation Terrestre* [B17] and U.S. Naval Observatory [B19]).

It is possible to calculate local time from the time provided by a gPTP domain using the `currentUtcOffset` field value of the time properties data set and knowledge of the local time zone and whether and when daylight savings time is observed.

8.2.4 Measurement of time within a gPTP domain

Time in a gPTP domain shall be measured as elapsed time since the PTP epoch.

8.3 Communication path asymmetry

This standard requires the measurement of the mean propagation time (also referred to as the *mean propagation delay*) between the two endpoint time-aware systems of a link. The measurement is performed by one of the time-aware systems, the initiator time-aware system, sending a message to the other time-aware system, the responder time-aware system. The responder then sends a message back to the initiator at a later time. The departure of the message sent by the initiator time-aware system is timestamped, and the timestamp value is retained by that system. The arrival of this message at the responder time-aware system is timestamped; the timestamp value is conveyed to the initiator time-aware system in a subsequent message. The departure of the response message sent by the responder time-aware system (in response to the message it receives from the initiator time-aware system) is timestamped, and the timestamp value is conveyed to the initiator time-aware system in a subsequent message. The arrival of this response message at the initiator time-aware system is timestamped, and the timestamp value is retained by that system. The mean propagation time is computed by the initiator time-aware system after receiving the response message, from the four timestamp values it has at this point.

Typically, the propagation time is not exactly the same in both directions, and the degree to which it differs in the two directions is characterized by the delay asymmetry. The relation between the individual propagation times in the two directions, the mean propagation time, and the delay asymmetry is as follows. Let t_{ir} be the propagation time from the initiator to the responder, t_{ri} be the propagation time from the responder to the initiator, meanPathDelay be the mean propagation time, and delayAsymmetry be the delay asymmetry. The propagation times in the two directions are illustrated in Figure 8-1.

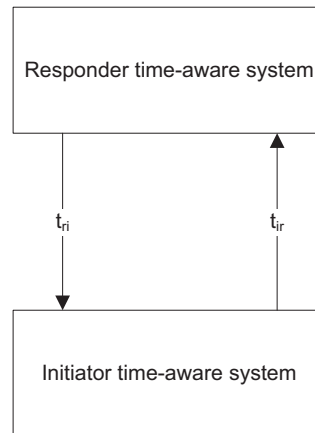

Figure 8-1—Propagation asymmetry

The meanPathDelay is the mean value of t_{ir} and t_{ri} , i.e., $\text{meanPathDelay} = (t_{ir} + t_{ri})/2$. The delayAsymmetry is defined as

$$t_{ir} = \text{meanPathDelay} - \text{delayAsymmetry}, \text{ and}$$

$$t_{ri} = \text{meanPathDelay} + \text{delayAsymmetry}.$$

In other words, delayAsymmetry is defined to be positive when the responder to initiator propagation time is longer than the initiator to responder propagation time.

This standard does not explicitly require the measurement of delayAsymmetry ; however, if delayAsymmetry is modeled, it shall be modeled as specified in this clause.

NOTE—A time-aware system can change the value of delayAsymmetry during operation using methods not specified in this standard.

8.4 Messages

8.4.1 General

All communications occur via PTP messages and/or media-specific messages.

8.4.2 Message attributes

8.4.2.1 General

All messages used in this standard have the following attributes:

- a) Message class
- b) Message type

The message class attribute is defined in this clause. The message type attribute is defined in 3.12. Some messages have additional attributes; these are defined in the subclauses where the respective messages are defined.

8.4.2.2 Message class

There are two message classes, the event message class and the general message class. Event messages are timestamped on egress from a time-aware system and ingress to a time-aware system. General messages are not timestamped. Every message is either an event message or a general message.

8.4.3 Generation of event message timestamps

All event messages are timestamped on egress and ingress. The timestamp shall be the time, relative to the LocalClock entity (see 10.1) at which the message timestamp point passes the reference plane marking the boundary between the time-aware system and the network media.

The definition of the timestamp measurement plane (see 3.22), along with the corrections defined as follows, allows transmission delays to be measured in such a way (at such a low layer) that they appear fixed and symmetrical to gPTP even though the MAC client might otherwise observe substantial asymmetry and transmission variation. For example, the timestamp measurement plane is located below any retransmission and queuing performed by the MAC.

NOTE 1—If an implementation generates event message timestamps using a point other than the message timestamp point, then the generated timestamps should be appropriately corrected by the time interval (fixed or otherwise) between the actual time of detection and the time the message timestamp point passed the reference plane. Failure to make these corrections results in a time offset between time-aware systems.

NOTE 2—In general, the timestamps may be generated at a timestamp measurement plane that is removed from the reference plane. Furthermore, the timestamp measurement plane, and therefore the time offset of this plane from the reference plane, is likely to be different for inbound and outbound event messages. To meet the requirement of this clause, the generated timestamps should be corrected for these offsets. Figure 8-2 illustrates these offsets. Based on this model the appropriate corrections are as follows:

$$\langle \text{egressTimestamp} \rangle = \langle \text{egressMeasuredTimestamp} \rangle + \text{egressLatency}$$

$$\langle \text{ingressTimestamp} \rangle = \langle \text{ingressMeasuredTimestamp} \rangle - \text{ingressLatency}$$

where the timestamps relative to the reference plane, $\langle \text{egressTimestamp} \rangle$ and $\langle \text{ingressTimestamp} \rangle$, are computed from the timestamps relative to the timestamp measurement plane, $\langle \text{egressMeasuredTimestamp} \rangle$ and $\langle \text{ingressMeasuredTimestamp} \rangle$, respectively, using their respective latencies, egressLatency and ingressLatency . Failure to make these corrections results in a time offset between the slave and master clocks.

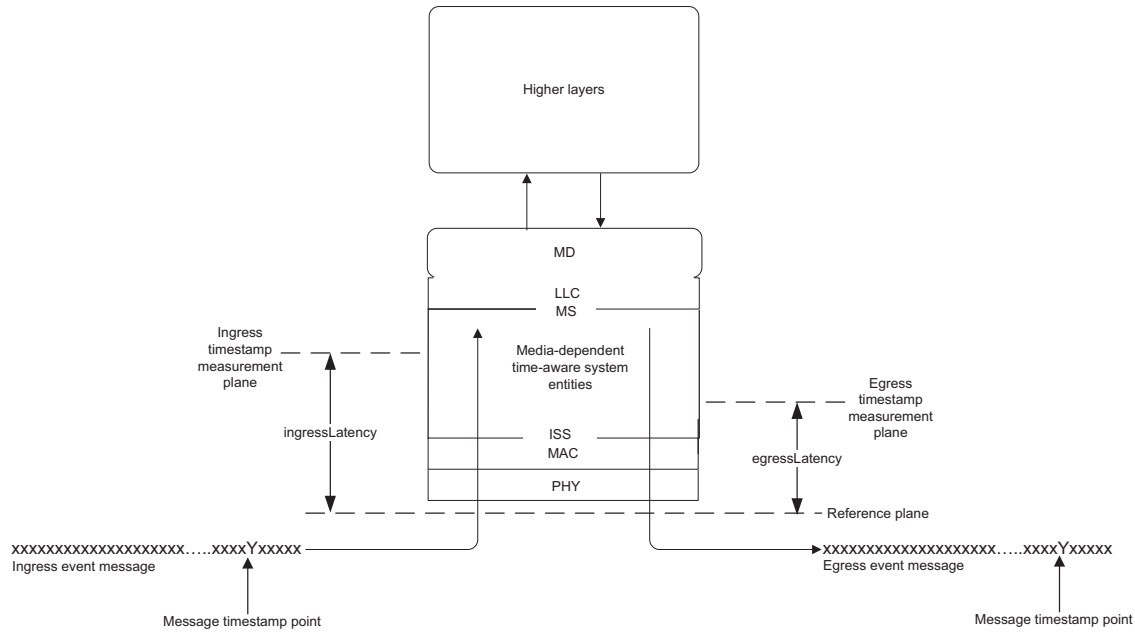

Figure 8-2—Definition of message timestamp point, reference plane, timestamp measurement plane, and latency constants

8.4.4 Priorities

The ISS priority for frames carrying IEEE 802.1AS messages shall be 6.

NOTE—Frames carrying IEEE 802.1AS messages are neither VLAN-tagged nor priority-tagged, i.e., they are untagged, see 11.3.3.

8.5 Ports

8.5.1 General

The time-aware systems in a gPTP domain interface with the network media via physical ports. gPTP defines a logical port in such a way that communication between time-aware systems is point-to-point even over physical ports that are attached to shared media. One logical port, consisting of one PortSync entity and one MD entity, is instantiated for each time-aware system with which the time-aware system communicates. In the case of shared media, multiple logical ports can be associated with a single physical port.

Unless otherwise qualified, each instance of the term *port* refers to a *logical port*.

8.5.2 Port identity

8.5.2.1 General

A port is identified by a port identity of type PortIdentity, see 6.3.3.7. The value is maintained in the portIdentity member of the port parameter data set, see 14.6.2. A port identity consists of the following two attributes:

- a) portIdentity.clockIdentity
- b) portIdentity.portNumber

8.5.2.2 clockIdentity

8.5.2.2.1 General

The clockIdentity is an 8-octet array formed by mapping an IEEE EUI-48 assigned to the time-aware system to IEEE EUI-64 format (i.e., to an array of 8 octets). The EUI-48 shall be an Ethernet MAC address owned by the organization creating the instance of a clockIdentity under the terms of this subclause. The organization owning the MAC address shall ensure that the MAC address is used in generating only a single instance of a clockIdentity, for example by requiring that the MAC address be a MAC address embedded in the device identified by the clockIdentity. The mapping rules for constructing the EUI-64 from the EUI-48 shall be those specified by the IEEE (see [B2]). The 8 octets of the created IEEE EUI-64 shall be assigned in order to the 8-octet array clockIdentity with most significant octet of the IEEE EUI-64 assigned to the clockIdentity octet array member with index 0.

NOTE 1—When using an EUI-48, the first 3 octets, i.e., the OUI portion, of the IEEE EUI-48 are assigned in order to the first 3 octets of the clockIdentity with most significant octet of the IEEE EUI-64, i.e., the most significant octet of the OUI portion, assigned to the clockIdentity octet array member with index 0. Octets with index 3 and 4 have hex values 0xFF and 0xFE respectively. The remaining 3 octets of the IEEE EUI-48 are assigned in order to the last 3 octets of the clockIdentity (see [B2]).

NOTE 2—The least and next to least significant bits of the most significant octet of the OUI indicate respectively: whether the address is an individual or group address, and whether the address is administered universally by the IEEE or locally.

NOTE 3—The clockIdentity is used by this standard as a unique identifier and not as a network address.

NOTE 4—Informative example (see [B2]): The OUI for Company X is 0xACDE48. If Company X wished to use an EUI-48 assigned number of 0xACDE48234567 as part of the clockIdentity, the resulting clockIdentity would be: 0xACDE48FFFE234567, where the 3 octet array 0x234567 would be ensured by Company X to be unique among all Company X assigned EUI-48 numbers. The byte and bit representations are illustrated in Table 8-1, see [B2].

Table 8-1—Illustration of formation of clockIdentity from EUI-48

OUI			EUI-48 assigned values		extension identifier		
octet[0] (most sig- nificant) octet[1]		octet[2]	octet[3]	octet[4]	octet[5]	octet[6]	octet[7] (least sig- nificant)
0xAC	0xDE	0x48	0xFF	0xFE	0x23	0x45	0x67
10101100 (leftmost 1 is most sig- nificant)	11011110b	01001000b	11111111b	11111110b	00100011b	01000101b	01100111b (rightmost 1 is least significant)

8.5.2.2.2 Reserved clockIdentity value

The clockIdentity value consisting of all ones shall be reserved for designating all clocks in the gPTP domain.

8.5.2.3 Port number

The portNumber value for a port on a time-aware end station (i.e., a time-aware system supporting a single port) shall be 1. The portNumber values for the ports on a time-aware Bridge supporting N ports shall be 1, 2, ..., N , respectively.

8.5.2.4 Ordering of clockIdentity and portIdentity values

Two clockIdentity values X and Y are compared as follows. Let x be the unsigned integer formed by concatenating octets 0 through 7 of X such that octet $j+1$ follows octet j (i.e., is less significant than octet j) in x ($j = 0, 1, \dots, 7$). Let y be the unsigned integer formed by concatenating octets 0 through 7 of Y such that octet $j+1$ follows octet j (i.e., is less significant than octet j) in y ($j = 0, 1, \dots, 7$). Then

- a) $X = Y$ if and only if $x = y$,
- b) $X > Y$ if and only if $x > y$, and
- c) $X < Y$ if and only if $x < y$.

Two portIdentity values A and B with members clockIdentity and portNumber are compared as follows. Let a be the unsigned integer formed by concatenating octets 0 through 7 of A .clockIdentity, such that octet $j+1$ follows octet j (i.e., is less significant than octet j) in a ($j = 0, 1, \dots, 7$), followed by octet 0 of A .portNumber, followed by octet 1 of A .portNumber. Let b be the unsigned integer formed by concatenating octets 0 through 7 of B .clockIdentity, such that octet $j+1$ follows octet j (i.e., is less significant than octet j) in b ($j = 0, 1, \dots, 7$), followed by octet 0 of B .portNumber, followed by octet 1 of B .portNumber. Then

- d) $A = B$ if and only if $a = b$,
- e) $A > B$ if and only if $a > b$, and
- f) $A < B$ if and only if $a < b$.

A portIdentity A with members clockIdentity and portNumber and a clockIdentity B are compared as follows. The unsigned integer a is formed from portIdentity A as described above. The unsigned integer b is formed by first forming a portIdentity B' whose clockIdentity is B and portNumber is 0. b is then formed from B' as described above. A and B are then compared as described in items d) through f) above.

8.6 Time-aware system characterization

8.6.1 Time-aware system type

There are two types of time-aware systems used in a gPTP domain, as follows:

- a) time-aware end station
- b) time-aware Bridge

All time-aware systems are identified by clockIdentity.

In addition, time-aware systems are characterized by the following attributes:

- c) priority1
- d) clockClass

- e) clockAccuracy
- f) offsetScaledLogVariance
- g) priority2
- h) clockIdentity
- i) timeSource
- j) numberPorts

NOTE—Attributes c) through i) can be considered to be associated with the ClockMaster entity of the time-aware system.

8.6.2 Time-aware system attributes

8.6.2.1 priority1

priority1 is used in the execution of the BMCA, see 10.3. The value of priority1 is an integer selected from the range 0 through 255. The ordering of priority1 in the operation of the BMCA, see 10.3.4 and 10.3.5, is specified as follows. A ClockMaster A shall be deemed better than a ClockMaster B if the value of priority1 of A is numerically less than that of B.

The value of priority1 shall be 255 for a time-aware system that is not grandmaster-capable. The value of priority1 shall be less than 255 for a time-aware system that is grandmaster-capable. The value 0 shall be reserved for management use, i.e., the value of priority1 shall be set to 0 only via management action and shall not be specified as a default value by a user of this standard. In the absence of a default value set by a user of this standard, the default value shall be set as indicated in Table 8-2.

Table 8-2—Default values for priority1, for the respective media

System type	Default value for priority1
Network infrastructure time-aware system	246
Portable time-aware system	250
Other time-aware systems	248

NOTE 1—The BMCA, see 10.3, considers priority1 before other attributes; the priority1 attribute can therefore be used to force a desired ordering of time-aware end stations for best master selection.

NOTE 2—The previous settings for priority1 guarantee that a time-aware system that is grandmaster-capable is always preferred by the BMCA to a time-aware system that is not grandmaster-capable.

NOTE 3—These values are assigned so that fixed devices that are available are selected as grandmaster over those devices that are more likely to be removed or powered down.

8.6.2.2 clockClass

The clockClass attribute denotes the traceability of the synchronized time distributed by a ClockMaster when it is the grandmaster.

The value shall be selected as follows:

- a) If the Default Parameter Data Set member gmCapable is TRUE, then

- 1) clockClass is set to the value that reflects the combination of the LocalClock and ClockSource entities; else
- 2) if the value that reflects the LocalClock and ClockSource entities is not specified or not known, clockClass is set to 248;
- b) If the Default Parameter Data Set member gmCapable is FALSE (see 8.6.2.1), clockClass is set to 255.

See 7.6.2.4 of IEEE Std 1588-2008 for a more detailed description of clockClass.

NOTE—The time-aware system has a LocalClock entity, which may be the free-running quartz crystal that just meets the IEEE 802.3 requirements, but could also be better. There can be a ClockSource entity, e.g., timing taken from GPS, available in the local system that provides timing to the ClockSource entity. The time provided by the time-aware system, if it is the grandmaster, is reflected by the combination of these two entities, and the clockClass should reflect this combination as specified in 7.6.2.4 of IEEE Std 1588-2008. For example, when the LocalClock entity uses a quartz oscillator that meets the requirements of IEEE Std 802.3-2008 and B.1 of this standard, clockClass may be set to 248. But, if a GPS receiver is present and synchronizes the time-aware system, then the clockClass may be set to the value 6, indicating traceability to a primary reference time source (see 7.6.2.4 of IEEE Std 1588-2008).

8.6.2.3 clockAccuracy

The clockAccuracy attribute indicates the expected time accuracy of a ClockMaster.

The value shall be selected as follows:

- a) clockAccuracy is set to the value that reflects the combination of the LocalClock and ClockSource entities; else
- b) if the value that reflects the LocalClock and ClockSource entities is not specified or unknown, clockAccuracy is set to 254 (FE_{16}).

See 7.6.2.5 of IEEE Std 1588-2008 for more detailed description of clockAccuracy.

8.6.2.4 offsetScaledLogVariance

The offsetScaledLogVariance is scaled, offset representation of an estimate of the PTP variance. The PTP variance characterizes the precision and frequency stability of the ClockMaster. The PTP variance is the square of PTPDEV (see B.1.3.2).

The value shall be selected as follows:

- a) offsetScaledLogVariance is set to the value that reflects the combination of the LocalClock and ClockSource entities; else
- b) if the value that reflects these entities is not specified or not known, offsetScaledLogVariance is set to 16640 (4100_{16}). This value corresponds to the value of PTPDEV for observation interval equal to the default Sync message transmission interval (i.e., observation interval of 0.125 s, see 11.5.2.3 and B.1.3.2).

See 7.6.3 of IEEE Std 1588-2008 for more detailed description of PTP variance and offsetScaledLogVariance (7.6.3.3 of IEEE Std 1588-2008 provides a detailed description of the computation of offsetScaledLogVariance from PTP variance, along with an example).

8.6.2.5 priority2

priority2 is used in the execution of the BMCA, see 10.3. The value of priority2 shall be an integer selected from the range 0 through 255. The ordering of priority2 in the operation of the BMCA is the same as the ordering of priority1, see 8.6.2.1.

The default value of priority2 shall be 248. See 7.6.2.3 of IEEE Std 1588-2008 for a more detailed description of priority2.

8.6.2.6 clockIdentity

The clockIdentity value for a time-aware system shall be as specified in 8.5.2.2.

8.6.2.7 timeSource

The timeSource is an information only attribute indicating the type of source of time used by a ClockMaster. The value is not used in the selection of the grandmaster. The values shall be as specified in Table 8-3. These represent categories. For example, the GPS entry would include not only the GPS system of the U.S. Department of Defense but the European Galileo system and other present and future satellite-based timing systems.

All unused values are reserved.

See 7.6.2.6 of IEEE Std 1588-2008 for a more detailed description of timeSource.

The initialization value is selected as follows:

- a) If the timeSource (8.6.2.7 and Table 8-3) is known at the time of initialization, the value is derived from the table, else
- b) The value is set to A0₁₆ (INTERNAL_OSCILLATOR).

8.6.2.8 numberPorts

The numberPorts indicates the number of ports on the time-aware system.

Table 8-3—timeSource enumeration

Value	Time source	Description
0x10	ATOMIC_CLOCK	Any device, or device directly connected to such a device, that is based on atomic resonance for frequency and that has been calibrated against international standards for frequency and time
0x20	GPS	Any device synchronized to any of the satellite systems that distribute time and frequency tied to international standards
0x30	TERRESTRIAL_RADIO	Any device synchronized via any of the radio distribution systems that distribute time and frequency tied to international standards
0x40	PTP	Any device synchronized to an IEEE 1588 PTP-based source of time external to the gPTP domain. See NOTE.
0x50	NTP	Any device synchronized via NTP to servers that distribute time and frequency tied to international standards
0x60	HAND_SET	Used in all cases for any device whose time has been set by means of a human interface based on observation of an international standards source of time to within the claimed clock accuracy
0x90	OTHER	Any source of time and/or frequency not covered by other values, or for which the source is not known
0xA0	INTERNAL_OSCILLATOR	Any device whose frequency is not based on atomic resonance nor calibrated against international standards for frequency, and whose time is based on a free-running oscillator with epoch determined in an arbitrary or unknown manner
<p>NOTE—For example, a clock that implements both the gPTP domain and another IEEE 1588 (i.e., PTP) domain, and is synchronized by the other IEEE 1588 domain, would have time source of PTP in the gPTP domain.</p>		

9. Application interfaces

9.1 Overview of the interfaces

The following subclauses define one application interface between the ClockSource entity and ClockMaster entity (see 10.1.1) and four application interfaces between the ClockTarget entity and ClockSlave entity (see 10.1.1). The ClockSource is an entity that can be used as an external timing source for the gPTP domain. The ClockSource entity either contains or has access to a clock (see 3.3). The ClockTarget entity represents any application that uses information provided by the ClockSlave entity via any of the application interfaces.

NOTE—The manner in which the ClockSource entity obtains time from a clock is outside the scope of this standard. The manner in which the ClockTarget uses the information provided by application interfaces is outside the scope of this standard.

The five interfaces are illustrated in Figure 9-1. They include the following:

- a) the ClockSourceTime interface, which provides external timing to a time-aware system,
- b) the ClockTargetEventCapture interface, which returns the synchronized time of an event signaled by a ClockTarget entity,
- c) the ClockTargetTriggerGenerate interface, which causes an event to be signaled at a synchronized time specified by a ClockTarget entity,
- d) the ClockTargetClockGenerator interface, which causes a periodic sequence of results to be generated, with a phase and rate specified by a ClockTarget entity, and
- e) the ClockTargetPhaseDiscontinuity interface, which supplies information that an application can use to determine if a discontinuity in grandmaster phase or frequency has occurred.

NOTE—The application interfaces described in this clause are models for behavior and not application program interfaces. Other application interfaces besides items a) through e) above are possible, but are not described here. In addition, there can be multiple instances of a particular interface.

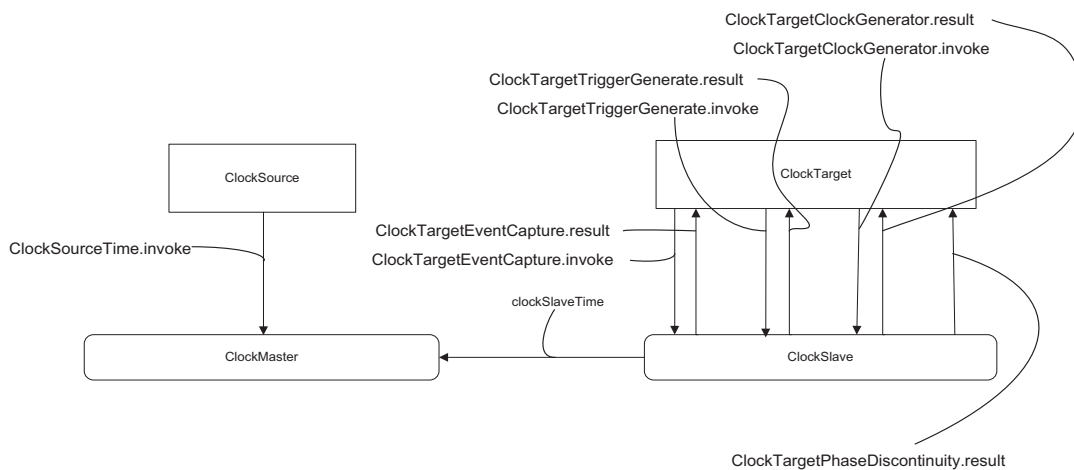

Figure 9-1—Application interfaces

9.2 ClockSourceTime interface

9.2.1 General

This interface is used by the ClockSource entity to provide time to the ClockMaster entity of a time-aware system. The ClockSource entity invokes the ClockSourceTime.invoke function to provide the time, relative to the ClockSource, that this function is invoked.

9.2.2 ClockSourceTime.invoke function parameters

```
ClockSourceTime.invoke {  
    sourceTime,  
    timeBaseIndicator,  
    lastGmPhaseChange,  
    lastGmFreqChange  
}
```

The parameter definitions are as follows:

9.2.2.1 sourceTime (ExtendedTimestamp)

The value of sourceTime is the time this function is invoked by the ClockSource entity.

9.2.2.2 timeBaseIndicator (UInteger16)

The timeBaseIndicator is a binary value that is set by the ClockSource entity. The ClockSource entity changes the value whenever its time base changes. The ClockSource entity shall change the value of timeBaseIndicator if and only if there is a phase or frequency change.

NOTE—While the clock that supplies time to the ClockSource entity can be lost, i.e., the time-aware system can enter holdover, the ClockSource entity itself is not lost. The ClockSource entity ensures that timeBaseIndicator changes if the source of time is lost.

9.2.2.3 lastGmPhaseChange (ScaledNs)

The value of lastGmPhaseChange is the phase change (i.e., change in sourceTime) that occurred on the most recent change in timeBaseIndicator. The value is initialized to 0.

9.2.2.4 lastGmFreqChange (Double)

The value of lastGmFreqChange is the fractional frequency change (i.e., frequency change expressed as a pure fraction) that occurred on the most recent change in timeBaseIndicator. The value is initialized to 0.

9.3 ClockTargetEventCapture interface

9.3.1 General

This interface is used by the ClockTarget entity to request the synchronized time of an event that it signals to the ClockSlave entity of a time-aware system. The ClockTarget entity invokes the ClockTargetEventCapture.invoke function to signal an event to the ClockSlave entity. The ClockSlave entity invokes the ClockTargetEventCapture.result function to return the time of the event relative to the current grandmaster or, if no time-aware system is grandmaster-capable, the LocalClock. The ClockTargetEventCapture.result function also returns gmPresent, to indicate to the ClockTarget whether or not a grandmaster is present.

9.3.2 ClockTargetEventCapture.invoke parameters

```
ClockTargetEventCapture.invoke {  
}
```

The function contains no parameters.

9.3.3 ClockTargetEventCapture.result parameters

```
ClockTargetEventCapture.result {  
    slaveTimeCallback,  
    gmPresent  
}
```

The parameter definitions are:

9.3.3.1 slaveTimeCallback (ExtendedTimestamp)

The value of `slaveTimeCallback` is the time, relative to the grandmaster, that the corresponding `ClockTargetEventCapture.invoke` function is invoked.

NOTE—The invocation of the `ClockTargetEventCapture.invoke` function and the detection of this invocation by the `ClockSlave` entity are simultaneous in this abstract interface.

9.3.3.2 gmPresent (Boolean)

The value of `gmPresent` is set equal to the value of the global variable `gmPresent` (see 10.2.3.13). This parameter indicates to the `ClockTarget` whether or not a grandmaster is present.

9.4 ClockTargetTriggerGenerate interface

9.4.1 General

This interface is used by the `ClockTarget` entity to request that the `ClockSlave` entity send a result at a specified time relative to the grandmaster. The `ClockTarget` entity invokes the `ClockTargetTriggerGenerate.invoke` function to indicate the synchronized time of the event. The `ClockSlave` entity invokes the `ClockTargetTriggerGenerate.result` function to either signal the event at the requested synchronized time or indicate an error condition.

9.4.2 ClockTargetTriggerGenerate.invoke parameters

```
ClockTargetTriggerGenerate.invoke {  
    slaveTimeCallback  
}
```

The parameter definition is:

9.4.2.1 slaveTimeCallback (ExtendedTimestamp)

If `slaveTimeCallback` is nonzero, its value is the synchronized time the corresponding `ClockTargetTriggerGenerate.result` function, i.e., the trigger, is to be invoked. If `slaveTimeCallback` is zero, any previous `ClockTargetTriggerGenerate.invoke` function for which a `ClockTargetTriggerGenerate.result` function has not yet been issued is canceled.

9.4.3 ClockTargetTriggerGenerate.result parameters

```
ClockTargetTriggerGenerate.result {  
    errorCondition,  
    gmPresent  
}
```

The parameter definitions are:

9.4.3.1 errorCondition (Boolean)

A value of FALSE indicates that the ClockTargetTriggerGenerate.result function was invoked at the time, relative to the grandmaster, contained in the corresponding ClockTargetTriggerGenerate.invoke function. A value of TRUE indicates that the ClockTargetTriggerGenerate.result function could not be invoked at the synchronized time contained in the corresponding ClockTargetTriggerGenerate.invoke function.

NOTE—For example, the ClockTargetTriggerGenerate.result function is invoked with errorCondition = TRUE if the requested slaveTimeCallback is a time prior to the synchronized time when the corresponding ClockTargetTriggerGenerate.invoke function is invoked. As another example, the ClockTargetTriggerGenerate.result function is invoked with errorCondition = TRUE if a discontinuity in the synchronized time causes the requested slaveTimeCallback to be skipped over.

9.4.3.2 gmPresent (Boolean)

The value of gmPresent is set equal to the value of the global variable gmPresent (see 10.2.3.13). This parameter indicates to the ClockTarget whether or not a grandmaster is present.

9.4.4 ClockTargetTriggerGenerate interface definition

The invocation of the ClockTargetTriggerGenerate.invoke function causes the ClockSlave entity to store the value of the slaveTimeCallback parameter in an internal variable (replacing any previous value of that variable) until the synchronized time, or LocalClock time if gmPresent is FALSE, equals the value of that variable, at which time the ClockTargetTriggerGenerate.result function is invoked with errorCondition = FALSE. If it is not possible to invoke the ClockTargetTriggerGenerate.result function at slaveTimeCallback, e.g., if slaveTimeCallback is earlier than the synchronized time (or LocalClock time if gmPresent is FALSE) when the ClockTargetTriggerGenerate.invoke function is invoked, the ClockTargetTriggerGenerate.result function is invoked with errorCondition = TRUE. Invocation of the ClockTargetTriggerGenerate.invoke function with slaveTimeCallback = 0 (which is earlier than any synchronized time) is used to cancel a pending request.

9.5 ClockTargetClockGenerator interface

9.5.1 General

This interface is used by the ClockTarget entity to request that the ClockSlave entity deliver a periodic clock signal of specified period and phase. The ClockTarget entity invokes the ClockTargetClockGenerator.invoke function to request that the ClockSlave entity generate the periodic clock signal. The ClockSlave entity invokes the ClockTargetClockGenerator.result function at significant instants of the desired clock signal.

9.5.2 ClockTargetClockGenerator.invoke parameters

```
ClockTargetClockGenerator.invoke {  
    clockPeriod,  
    slaveTimeCallbackPhase  
}
```

The parameter definitions are:

9.5.2.1 clockPeriod (TimeInterval)

The value of clockPeriod is the period between successive invocations of the ClockTargetClockGenerator.result function. A value that is zero or negative causes any existing periodic clock signal generated via this application interface to be terminated.

9.5.2.2 slaveTimeCallbackPhase (ExtendedTimestamp)

The value of slaveTimeCallbackPhase describes phase of the generated clock signal by specifying a point on the PTP timescale such that ClockTargetClockGenerator.result invocations occur at synchronized times that differ from slaveTimeCallbackPhase by $n \times \text{clockPeriod}$, where n is an integer.

NOTE—The value of slaveTimeCallbackPhase can be earlier or later than the synchronized time the ClockTargetClockGenerator.invoke function is invoked; use of a slaveTimeCallbackPhase value in the future does not imply that the initiation of the periodic clock signal is suppressed until that synchronized time.

9.5.3 ClockTargetClockGenerator.result parameters

The semantics of the function are:

```
ClockTargetClockGenerator.result {
    slaveTimeCallback,
}
```

The parameter definition is:

9.5.3.1 slaveTimeCallback (ExtendedTimestamp)

The value of slaveTimeCallback is the synchronized time of this event.

9.6 ClockTargetPhaseDiscontinuity interface

9.6.1 General

This interface provides discontinuity information, sent from the grandmaster, to an application within a station. It is used by the ClockSlave entity to supply sufficient information to the ClockTarget entity to enable the ClockTarget entity to determine whether a phase or frequency discontinuity has occurred. The ClockSlave invokes the ClockTargetPhaseDiscontinuity.result function in the SEND_SYNC_INDICATION block of the ClockSlaveSync state machine (see 10.2.12 and Figure 10-9). The invocation occurs when a PortSyncSync structure is received, after the needed information has been computed by the ClockSlaveSync state machine.

9.6.2 ClockTargetPhaseDiscontinuity.result parameters

```
ClockTargetPhaseDiscontinuity.result {
    gmIdentity,
    gmTimeBaseIndicator,
    lastGmPhaseChange,
    lastGmFreqChange
}
```

The parameter definitions are:

9.6.2.1 gmIdentity (ClockIdentity)

If gmPresent (see 10.2.3.13) is TRUE, the value of gmIdentity is the ClockIdentity of the current grandmaster. If gmPresent is FALSE, the value of gmIdentity is 0x0.

9.6.2.2 gmTimeBaseIndicator (UInteger16)

The value of gmTimeBaseIndicator is the timeBaseIndicator of the current grandmaster.

9.6.2.3 lastGmPhaseChange (ScaledNs)

The value of the global lastGmPhaseChange parameter (see 10.2.3.16) received from the grandmaster.

9.6.2.4 lastGmFreqChange (Double)

The value of lastGmFreqChange parameter (see 10.2.3.17) received from the grandmaster.

10. Media-independent layer specification

10.1 Overview

10.1.1 Model of operation

A time-aware system contains a best master selection function and a synchronization function. These functions include port-specific aspects and aspects associated with the time-aware system as a whole. The functions are distributed among a number of entities, which together describe the behavior of a compliant implementation. The functions are specified by a number of state machines.

The model for the media-independent layer of a time-aware system is shown in Figure 10-1. It includes a single SiteSync entity, ClockMaster entity, and ClockSlave entity for the time-aware system as a whole, plus one PortSync and one MD entity for each port. The MD entity performs media-dependent functions, which are described in the clauses for the respective media. In addition to the entities, Figure 10-1 shows the information that flows between the entities via the PortSyncSync, MDSyncSend, and MDSyncReceive structures (see 10.2.2.3, 10.2.2.1, and 10.2.2.2, respectively).

The SiteSync, ClockMaster, ClockSlave, and PortSync entities each contain a number of cooperating state machines, which are described later in this clause (the MD entity state machines are described in the respective media-dependent clauses). The ClockMaster entity receives information from an external time source, referred to as a ClockSource entity (see 9.2), via an application interface, and provides the information to the SiteSync entity. The ClockSlave entity receives grandmaster time-synchronization and current grandmaster information from the SiteSync entity, and makes the information available to an external application, referred to as a clockTarget entity (see 9.3 through 9.6), via one or more application service interfaces. The SiteSync entity executes the portion of best master clock selection associated with the time-aware system as a whole, i.e., it uses the best master information received on each port to determine which port has received the best information, and updates the roles of all the ports (see 10.3.1 for a discussion of port roles). It also distributes synchronization information received on the SlavePort to all the ports whose role is MasterPort (see 10.3.1). The PortSync entity for a SlavePort receives best master selection information from the time-aware system at the other end of the associated link, compares this to the current best master information that it has, and forwards the result of the comparison to the Site Sync entity. The PortSync entity for a SlavePort also receives time-synchronization information from the MD entity associated with the port, and forwards it to the SiteSync entity. The PortSync entity for a MasterPort sends best master selection and time-synchronization information to the MD entity for the port, which in turn sends the respective messages.

NOTE—This clause does not require a one-to-one correspondence between the PortSync entities of time-aware systems attached to the same gPTP communication path (see 3.9), i.e., more than two time-aware systems can be attached to a gPTP communication path that uses a shared medium and meet the requirements of this clause. However, it is possible for a media-dependent clause to have additional requirements that limit the gPTP communication paths to point-to-point links for that medium; in this case, each link has exactly two PortSync entities, which can be considered to be in one-to-one correspondence. One example of this is the full-duplex, point-to-point media-dependent layer specified in Clause 11. In addition, one or more gPTP communication paths can be logically point-to-point but traverse the same shared medium.

The LocalClock entity is a free-running clock (see 3.3) that provides a common time to the time-aware system, relative to an arbitrary epoch. A time-aware system contains a LocalClock entity. The requirements for the LocalClock entity are specified in B.1. All timestamps are taken relative to the LocalClock entity (see 8.4.3). The LocalClock entity also provides the value of currentTime (see 10.2.3.12), which is used in the state machines to specify the various timers.

NOTE—The epoch for the LocalClock entity may be the time that the time-aware system is powered on.

The time-synchronization state machines are described in 10.2. The best master clock selection state machines are described in 10.3. The attributes and format of the Announce message are described in 10.4 and 10.5. The timing characterization of the protocol is described in 10.6.

10.1.2 Grandmaster-capable time-aware system

A time-aware system may be grandmaster-capable. An implementation may optionally provide the ability to configure a time-aware system as grandmaster-capable via a management interface.

NOTE—While a time-aware system that is not grandmaster-capable can never be the grandmaster of the gPTP domain, such a time-aware system contains a best master selection function, invokes the best master selection algorithm, and conveys synchronization information received from the current grandmaster.

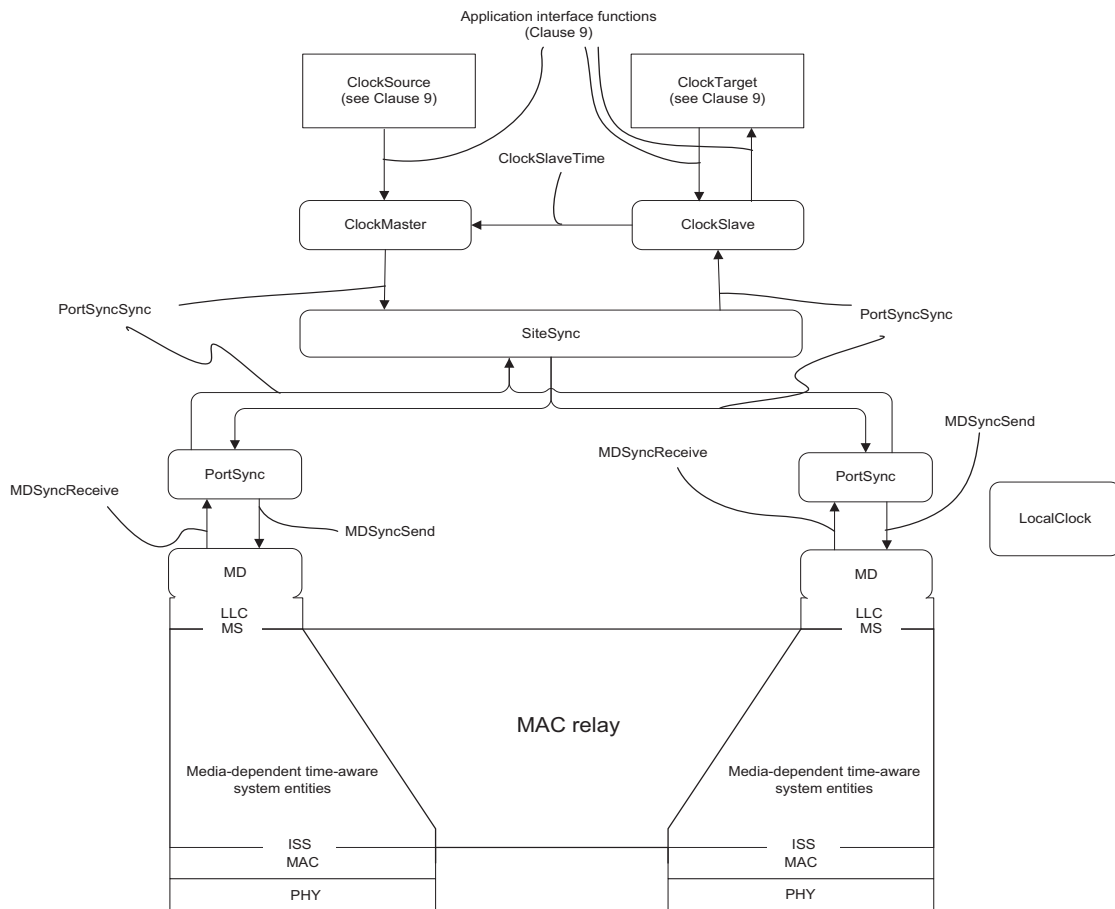

Figure 10-1—Model for media-independent layer of time-aware system

10.2 Time-synchronization state machines

10.2.1 Overview

The time-synchronization function in a time-aware system is specified by a number of cooperating state machines. Figure 10-2 is not itself a state machine, but illustrates the machines, their interrelationships, the principle variables and structures used to communicate between them, their local variables, and performance parameters. Figure 10-2 includes state machines that are described in the media-dependent clauses of this

standard, in order to illustrate the interrelationships between these state machines and the media-independent layer state machines described in this clause. Figure 10-2 does not show the application interface functions described in Clause 9, nor the service interface primitives between the media-dependent layer and the LLC.

The ClockMasterSyncReceive, ClockMasterSyncOffset, and ClockMasterSyncSend state machines are optional for time-aware systems that are not grandmaster-capable (see 8.6.2.1 and 10.1.2). These state machines may be present in a time-aware system that is not grandmaster-capable; however, any information supplied by them, via the ClockMasterSyncSend state machine, to the SiteSyncSync state machine is not used by the SiteSyncSync state machine if the time-aware system is not grandmaster-capable.

The media-independent layer state machines in Figure 10-2 are as follows:

- a) ClockMasterSyncReceive (one instance per time-aware system): receives ClockSourceTime.invoke functions from the ClockSource entity and notifications of LocalClock entity ticks (see 10.2.3.18), updates masterTime, and provides masterTime to ClockMasterSyncOffset and ClockMasterSyncSend state machines. This state machine is optional for time-aware systems that are not grandmaster-capable (see 8.6.2.1 and 10.1.2).
- b) ClockMasterSyncOffset (one instance per time-aware system): receives syncReceiptTime from the ClockSlave entity and masterTime from the ClockMasterSyncReceive state machine, computes phase offset and frequency offset between masterTime and syncReceiptTime if the time-aware system is not the grandmaster, and provides the frequency and phase offsets to the ClockMasterSyncSend state machine. This state machine is optional for time-aware systems that are not grandmaster-capable (see 8.6.2.1 and 10.1.2).
- c) ClockMasterSyncSend (one instance per time-aware system): receives masterTime from the ClockMasterSyncReceive state machine, receives phase and frequency offset between masterTime and syncReceiptTime from the ClockMasterSyncOffset state machine, and provides masterTime (i.e., synchronized time) and the phase and frequency offset to the SiteSync entity using a PortSyncSync structure. This state machine is optional for time-aware systems that are not grandmaster-capable (see 8.6.2.1 and 10.1.2).
- d) PortSyncSyncReceive (one instance per port): receives time-synchronization information from the MD entity of the corresponding port, computes accumulated rateRatio, computes syncReceiptTimeoutTime, and sends the information to the SiteSync entity.
- e) SiteSyncSync (one instance per time-aware system): receives time-synchronization information, accumulated rateRatio, and syncReceiptTimeoutTime from the PortSync entity of the current slave port or from the ClockMaster entity, and sends the information to the PortSync entities of all the ports and to the ClockSlave entity.
- f) PortSyncSyncSend (one instance per port): receives time-synchronization information from the SiteSync entity, requests that the MD entity of the corresponding port send a time-synchronization event message, receives the <syncEventEgressTimestamp> for this event message from the MD entity, uses the most recent time-synchronization information received from the SiteSync entity and the timestamp to compute time-synchronization information that will be sent by the MD entity in a general message (e.g., for full-duplex IEEE 802.3 media) or a subsequent event message (e.g., for IEEE 802.11 media), and sends this latter information to the MD entity.
- g) ClockSlaveSync (one instance per time-aware system): receives time-synchronization information from the SiteSync entity, computes clockSlaveTime and syncReceiptTime, sets syncReceiptLocalTime, GmTimeBaseIndicator, lastGmPhaseChange, lastGmFreqChange, sends clockSlaveTime to the ClockMaster entity, and provides information to the ClockTarget entity (via the ClockTargetPhaseDiscontinuity interface, see 9.6) to enable that entity to determine if a phase or frequency discontinuity has occurred.

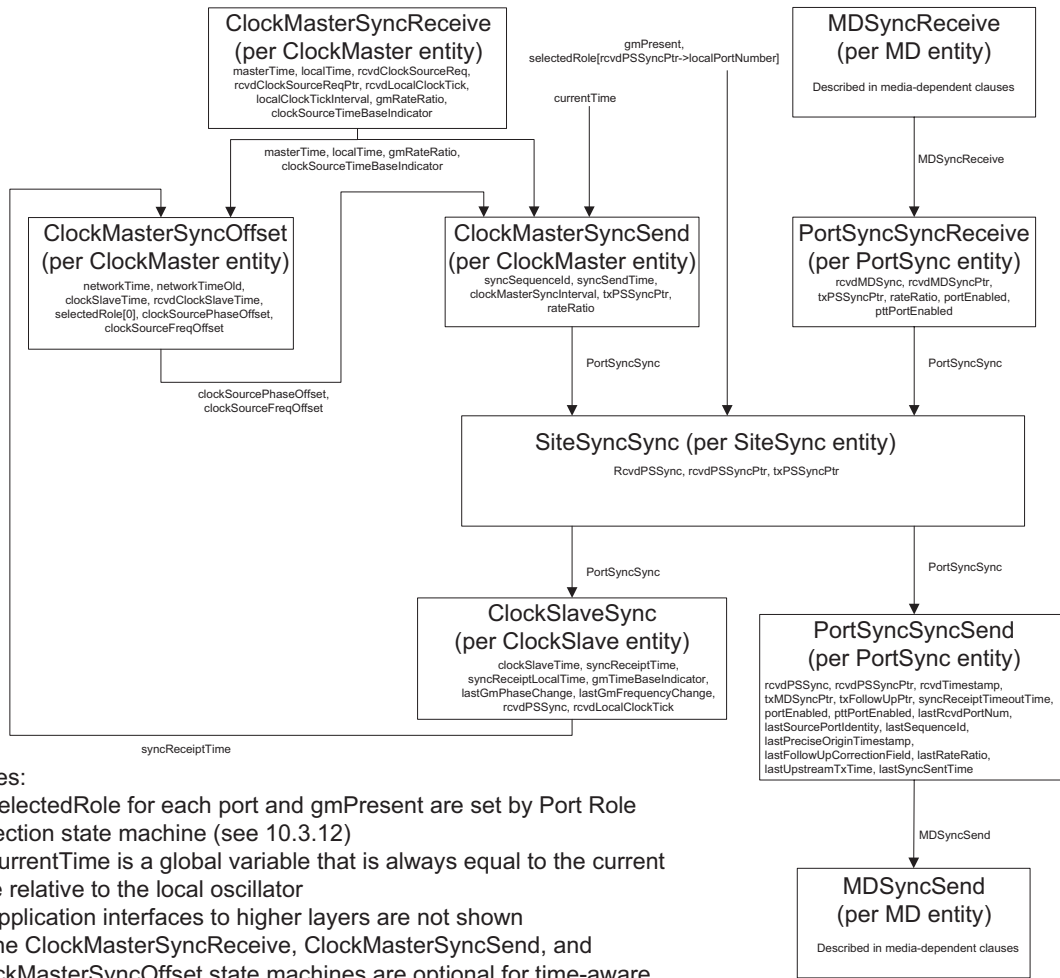

- Notes:
- a) selectedRole for each port and gmPresent are set by Port Role Selection state machine (see 10.3.12)
 - b) currentTime is a global variable that is always equal to the current time relative to the local oscillator
 - c) application interfaces to higher layers are not shown
 - d) the ClockMasterSyncReceive, ClockMasterSyncSend, and ClockMasterSyncOffset state machines are optional for time-aware systems that are not grandmaster-capable.

Figure 10-2—Time-synchronization state machines—overview and interrelationships

10.2.2 Data structures communicated between state machines

The following subclauses describe the data structures communicated between the time-synchronization state machines.

10.2.2.1 MDSyncSend

10.2.2.1.1 General

This structure contains information that is sent by the PortSync entity of a port to the MD entity of that port when requesting that the MD entity cause time-synchronization information to be sent. The structure contains information that reflects the most recent time-synchronization information received by this time-aware system, and is used to determine the contents of the time-synchronization event message and possibly separate general message that will be sent by this port.

The structure is:

```
MDSyncSend {
    followUpCorrectionField,
    sourcePortIdentity,
    logMessageInterval,
    preciseOriginTimestamp,
    upstreamTxTime,
    rateRatio,
    gmTimeBaseIndicator,
    lastGmPhaseChange,
    lastGmFreqChange
}
```

The members of the structure are defined in the following subclauses.

10.2.2.1.2 followUpCorrectionField (ScaledNs)

The followUpCorrectionField contains the accumulated time since the preciseOriginTimestamp was captured by the grandmaster. This is equal to the elapsed time, relative to the grandmaster, between the time the grandmaster sent the received time-synchronization event message, truncated to the nearest nanosecond, and the time at which that event message was sent by the upstream time-aware system. The followUpCorrectionField is equal to the value of the followUpCorrectionField member of the most recently received PortSyncSync structure from the PortSync entity of this port (see 10.2.2.3.4).

10.2.2.1.3 sourcePortIdentity (PortIdentity)

The sourcePortIdentity is the portIdentity of this port (see 8.5.2).

10.2.2.1.4 logMessageInterval (Integer8)

The logMessageInterval is the value of currentLogSyncInterval for this port (see 10.6.2.3).

10.2.2.1.5 preciseOriginTimestamp (Timestamp)

The preciseOriginTimestamp is the sourceTime of the ClockMaster entity of the grandmaster, with any fractional nanoseconds truncated, when the received time-synchronization information was sent by the grandmaster. The preciseOriginTimestamp is the value of the preciseOriginTimestamp member of the most recently received PortSyncSync structure from the PortSync entity of this port (see 10.2.2.3.7).

10.2.2.1.6 upstreamTxTime (UScaledNs)

The upstreamTxTime is the value of the <syncEventIngressTimestamp> corresponding to the receipt of the time-synchronization information, minus the mean propagation time on the link attached to this port divided by neighborRateRatio (see 10.2.4.6). The upstreamTxTime is the value of the upstreamTxTime member of the most recently received PortSyncSync structure from the PortSync entity of this port (see 10.2.2.3.8).

10.2.2.1.7 rateRatio (Double)

The rateRatio is the value of the rateRatio member of the most recently received PortSyncSync structure from the PortSync entity of this port (see 10.2.2.3.9). It is equal to the ratio of the frequency of the grandmaster to the frequency of the LocalClock entity of this time-aware system (see 10.2.7.1.4).

10.2.2.1.8 gmTimeBaseIndicator (UInteger16)

The gmTimeBaseIndicator is the timeBaseIndicator of the ClockSource entity of the current grandmaster. It is set equal to the gmTimeBaseIndicator of the received time-synchronization information. The gmTimeBaseIndicator is the value of the gmTimeBaseIndicator member of the most recently received PortSyncSync structure from the PortSync entity of this port (see 10.2.2.3.10).

10.2.2.1.9 lastGmPhaseChange (ScaledNs)

The lastGmPhaseChange is the time of the current grandmaster minus the time of the previous grandmaster, at the time that the current grandmaster became grandmaster, or the step change in the time of the current grandmaster at the time of the most recent gmTimeBaseIndicator change. It is set equal to the lastGmPhaseChange of the received time-synchronization information. The lastGmPhaseChange is the value of the lastGmPhaseChange member of the most recently received PortSyncSync structure from the PortSync entity of this port (see 10.2.2.3.11).

10.2.2.1.10 lastGmFreqChange (Double)

The lastGmFreqChange is the fractional frequency offset of the current grandmaster relative to the previous grandmaster, at the time that the current grandmaster became grandmaster, or relative to itself prior to the last change in gmTimeBaseIndicator. It is set equal to the lastGmFreqChange of the received time-synchronization information. The lastGmFreqChange is the value of the lastGmFreqChange member of the most recently received PortSyncSync structure from the PortSync entity of this port (see 10.2.2.3.12).

10.2.2.2 MDSyncReceive

10.2.2.2.1 General

This structure contains information that is sent by the MD entity of a port to the PortSync entity of that port. It provides the PortSync entity with master clock timing information and timestamp of receipt of a time-synchronization event message compensated for propagation time on the upstream link. The information is sent to the PortSync entity upon receipt of time-synchronization information by the MD entity of the port. The information is in turn provided by the PortSync entity to the SiteSync entity. The information is used by the SiteSync entity to compute the rate ratio of the local oscillator relative to the master and is communicated to the other PortSync entities for use in computing master clock timing information.

The structure is:

```
MDSyncReceive {
    followUpCorrectionField,
    sourcePortIdentity,
    logMessageInterval,
    preciseOriginTimestamp,
    upstreamTxTime,
    rateRatio,
    gmTimeBaseIndicator,
    lastGmPhaseChange,
    lastGmFreqChange
}
```

The members of the structure are defined in the following subclauses.

10.2.2.2.2 followUpCorrectionField (ScaledNs)

The followUpCorrectionField contains the elapsed time, relative to the grandmaster, between the time the grandmaster sent the received time-synchronization information, truncated to the nearest nanosecond, and the time at which this information was sent by the upstream time-aware system.

NOTE 1—The sum of followUpCorrectionField and preciseOriginTimestamp is the synchronized time that corresponds to the time the most recently received time-synchronization event message was sent by the upstream time-aware system.

NOTE 2—For a medium that uses separate event and general messages (for example, full-duplex, point-to-point media described in Clause 11), the event message corresponding to the most recently received network synchronization information is the event message that corresponds to the most recently received general message. For a medium that places synchronization information based on the event message timestamp in the next event message (for example, IEEE 802.11 media described in Clause 12), the event message corresponding to the most recently received network synchronization information is the previous event message; in this case, the time-synchronization information in the current event message refers to the previous event message.

10.2.2.2.3 sourcePortIdentity (PortIdentity)

The sourcePortIdentity is the value of the sourcePortIdentity of the time-synchronization event message received by this port. It is the portIdentity of the upstream MasterPort that sent the event message.

10.2.2.2.4 logMessageInterval (Integer8)

The logMessageInterval is the value of the logMessageInterval of the time-synchronization event message received by this port. It is the currentLogSyncInterval (see 10.6.2.3) of the upstream MasterPort that sent the event message.

10.2.2.2.5 preciseOriginTimestamp (Timestamp)

The preciseOriginTimestamp is the sourceTime of the ClockMaster entity of the grandmaster, with any fractional nanoseconds truncated, when the time-synchronization event message was sent by the grandmaster.

10.2.2.2.6 upstreamTxTime (UScaledNs)

The upstreamTxTime is the value of the <syncEventIngressTimestamp> corresponding to the receipt of the time-synchronization event message, minus the mean propagation time on the link attached to this port divided by neighborRateRatio (see 10.2.4.6).

10.2.2.2.7 rateRatio (Double)

The rateRatio is the value of rateRatio of the received time synchronization information. It is equal to the ratio of the frequency of the grandmaster to the frequency of the LocalClock entity of the time-aware system at the other end of the link attached to this port, i.e., the time-aware system that sent the most recently received time-synchronization event message (see 10.2.7.1.4).

10.2.2.2.8 gmTimeBaseIndicator (UInteger16)

The gmTimeBaseIndicator is the timeBaseIndicator of the ClockSource entity of the current grandmaster. It is set equal to the gmTimeBaseIndicator of the received time-synchronization information.

10.2.2.2.9 lastGmPhaseChange (ScaledNs)

The lastGmPhaseChange is the time of the current grandmaster minus the time of the previous grandmaster, at the time that the current grandmaster became grandmaster, or the step change in the time of the current grandmaster at the time of the most recent gmTimeBaseIndicator change. It is set equal to the lastGmPhaseChange of the received time-synchronization information.

10.2.2.2.10 lastGmFreqChange (Double)

The lastGmFreqChange is the fractional frequency offset of the current grandmaster relative to the previous grandmaster, at the time that the current grandmaster became grandmaster, or relative to itself prior to the last change in gmTimeBaseIndicator. It is set equal to the lastGmFreqChange of the received time-synchronization information.

10.2.2.3 PortSyncSync

10.2.2.3.1 General

This structure is sent by the PortSync and ClockMaster entities to the SiteSync entity, and also from the SiteSync entity to the PortSync and ClockSlave entities.

When sent from the PortSync or ClockMaster entity, it provides the SiteSync entity with master clock timing information, timestamp of receipt of a time-synchronization event message compensated for propagation time on the upstream link, and the time at which sync receipt timeout occurs if a subsequent Sync message is not received by then. The information is used by the SiteSync entity to compute the rate ratio of the local oscillator relative to the master and is communicated to the other PortSync entities for use in computing master clock timing information.

When sent from the SiteSync entity to the PortSync or ClockMaster entity, the structure contains information needed to compute the synchronization information that will be included in respective fields of the time-synchronization event and general messages that will be sent, and also to compute the synchronized time that the ClockSlave entity will supply to the ClockTarget entity.

The structure is:

```
PortSyncSync {
    localPortNumber,
    syncReceiptTimeoutTime,
    followUpCorrectionField,
    sourcePortIdentity,
    logMessageInterval,
    preciseOriginTimestamp,
    upstreamTxTime,
    rateRatio,
    gmTimeBaseIndicator,
    lastGmPhaseChange,
    lastGmFreqChange
}
```

The parameters of the PortSyncSync structure are defined in the following subclauses for the case where the structure is sent from the PortSync or ClockMaster entity to the SiteSync entity. If the structure is sent from the SiteSync entity to the PortSync or ClockSlave entity, the member values are copied from the most recently received PortSyncSync structure where the port that received this structure has port role of SlavePort.

10.2.2.3.2 localPortNumber (UInteger16)

If the structure is sent by a PortSync entity, the localPortNumber is the port number of the port whose PortSync entity sent this structure. If the structure is sent by a ClockMaster entity, the localPortNumber is zero.

10.2.2.3.3 syncReceiptTimeoutTime (UScaledNs)

If the structure is sent by a PortSync entity, the syncReceiptTimeoutTime is the value of the local time (i.e., the free-running, local oscillator time) at which sync receipt timeout occurs if a subsequent time-synchronization event message is not received by that time. If the structure is sent by a ClockMaster entity, the syncReceiptTimeoutTime is FFFFFFFFFFFFFFFF₁₆ [see 10.2.8.2.1, item h)].

10.2.2.3.4 followUpCorrectionField (ScaledNs)

If the structure is sent by a PortSync entity, the followUpCorrectionField is the value of the followUpCorrectionField member of the MDSyncReceive structure whose receipt caused the sending of this structure (see 10.2.2.2.2). If the structure is sent by a ClockMaster entity, the followUpCorrectionField is the sub-nanosecond portion of the ClockMaster time.

10.2.2.3.5 sourcePortIdentity (PortIdentity)

If the structure is sent by a PortSync entity, the sourcePortIdentity is the value of the sourcePortIdentity member of the MDSyncReceive structure whose receipt caused the sending of this structure (see 10.2.2.2.3). If the structure is sent by a ClockMaster entity, the clockIdentity member of the sourcePortIdentity is the clockIdentity of this time-aware system, and the portNumber member of the sourcePortIdentity is 0.

10.2.2.3.6 logMessageInterval (Integer8)

If the structure is sent by a PortSync entity, the logMessageInterval is the value of the logMessageInterval member of the MDSyncReceive structure whose receipt caused the sending of this structure (see 10.2.2.2.4). If the structure is sent by a ClockMaster entity, the logMessageInterval is the value of clockMasterLogSyncInterval (see 10.6.2.4).

10.2.2.3.7 preciseOriginTimestamp (Timestamp)

If the structure is sent by a PortSync entity, the preciseOriginTimestamp is the value of the preciseOriginTimestamp member of the MDSyncReceive structure whose receipt caused the sending of this structure (see 10.2.2.2.5). If the structure is sent by a ClockMaster entity, the preciseOriginTimestamp is the ClockMaster time truncated to the next lower nanosecond.

10.2.2.3.8 upstreamTxTime (UScaledNs)

If the structure is sent by a PortSync entity, the upstreamTxTime is the value of the upstreamTxTime member of the MDSyncReceive structure whose receipt caused the sending of this structure (see 10.2.2.2.6). If the structure is sent by a ClockMaster entity, the upstreamTxTime is the local oscillator time corresponding to the ClockMaster time.

10.2.2.3.9 rateRatio (Double)

If the structure is sent by a PortSync entity, the rateRatio is the value of the rateRatio member of the MDSyncReceive structure whose receipt caused the sending of this structure (see 10.2.2.2.7). It is equal to the ratio of the frequency of the grandmaster to the frequency of the LocalClock entity of the time-aware system at the other end of the link attached to this port, i.e., the time-aware system that sent the most

recently-received time-synchronization event message (see 10.2.7.1.4). If the structure is sent by a ClockMaster entity, the rateRatio is equal to gmRateRatio (see 10.2.3.14).

10.2.2.3.10 gmTimeBaseIndicator (UInteger16)

If the structure is sent by a PortSync entity, the gmTimeBaseIndicator is the value of the gmTimeBaseIndicator member of the MDSyncReceive structure whose receipt caused the sending of this structure (see 10.2.2.2.8). If the structure is sent by a ClockMaster entity, the gmTimeBaseIndicator is equal to clockSourceTimeBaseIndicator (see 10.2.3.8).

10.2.2.3.11 lastGmPhaseChange (ScaledNs)

If the structure is sent by a PortSync entity, the lastGmPhaseChange is the value of the lastGmPhaseChange member of the MDSyncReceive structure whose receipt caused the sending of this structure (see 10.2.2.2.8). If the structure is sent by a ClockMaster entity, the lastGmPhaseChange is equal to clockSourcePhaseOffset (see 10.2.3.7).

10.2.2.3.12 lastGmFreqChange (Double)

If the structure is sent by a PortSync entity, the lastGmFreqChange is the value of the lastGmFreqChange member of the MDSyncReceive structure whose receipt caused the sending of this structure (see 10.2.2.2.8). If the structure is sent by a ClockMaster entity, the lastGmFreqChange is equal to clockSourceFreqOffset (see 10.2.3.6).

10.2.3 Per-time-aware system global variables

10.2.3.1 BEGIN: a Boolean controlled by the system initialization. If BEGIN is true, all state machines, including per-port state machines, continuously execute their initial state.

10.2.3.2 clockMasterSyncInterval: a variable containing the mean time interval between successive messages providing time-synchronization information by the ClockMaster entity to the SiteSync entity. This value is given by $1000000000 \times 2^{\text{clockMasterLogSyncInterval}}$, where clockMasterLogSyncInterval is the logarithm to base 2 of the mean time between the successive providing of time-synchronization information by the ClockMaster entity (see 10.6.2.3). The data type for clockMasterSyncInterval is UScaledNs.

10.2.3.3 clockSlaveTime: the synchronized time maintained, at the slave, at the granularity of the LocalClock entity [i.e., a new value is computed every localClockTickInterval (see 10.2.3.18) by the ClockSlave entity]. The data type for clockSlaveTime is ExtendedTimestamp.

10.2.3.4 syncReceiptTime: the synchronized time computed by the ClockSlave entity at the instant time-synchronization information, contained in a PortSyncSync structure, is received. The data type for syncReceiptTime is ExtendedTimestamp.

10.2.3.5 syncReceiptLocalTime: the value of currentTime (i.e., the time relative to the LocalClock entity) corresponding to syncReceiptTime. The data type for syncReceiptLocalTime is UScaledNs.

10.2.3.6 clockSourceFreqOffset: the fractional frequency offset of the ClockSource entity frequency relative to the current grandmaster frequency. The data type for clockSourceFreqOffset is Double.

10.2.3.7 clockSourcePhaseOffset: the time provided by the ClockSource entity, minus the synchronized time. The data type for clockSourcePhaseOffset is ScaledNs.

10.2.3.8 clockSourceTimeBaseIndicator: a global variable that is set equal to the timeBaseIndicator parameter of the ClockSourceTime.invoke application interface function (see 9.2.2.2). That parameter is set

by the ClockSource entity and is changed by that entity whenever the time base changes. The data type for clockSourceTimeBaseIndicator is UInteger16.

10.2.3.9 clockSourceTimeBaseIndicatorOld: a global variable that is set equal to the previous value of clockSourceTimeBaseIndicator. The data type for clockSourceTimeBaseIndicatorOld is UInteger16.

10.2.3.10 clockSourceLastGmPhaseChange: a global variable that is set equal to the lastGmPhaseChange parameter of the ClockSourceTime.invoke application interface function (see 9.2.2.3). That parameter is set by the ClockSource entity and is changed by that entity whenever the time base changes. The data type for clockSourceLastGmPhaseChange is ScaledNs.

10.2.3.11 clockSourceLastGmFreqChange: a global variable that is set equal to the lastGmFreqChange parameter of the ClockSourceTime.invoke application interface function (see 9.2.2.4). That parameter is set by the ClockSource entity and is changed by that entity whenever the time base changes. The data type for clockSourceLastGmFreqChange is Double.

10.2.3.12 currentTime: the current value of time relative to the LocalClock entity clock. The data type for currentTime is UScaledNs.

10.2.3.13 gmPresent: a Boolean that indicates whether a grandmaster-capable time-aware system is present in the domain. If TRUE, a grandmaster-capable time-aware system is present; if FALSE, a grandmaster-capable time-aware system is not present.

10.2.3.14 gmRateRatio: the measured ratio of the frequency of the ClockSource entity to the frequency of the LocalClock entity. The data type for gmRateRatio is Double.

10.2.3.15 gmTimeBaseIndicator: the most recent value of gmTimeBaseIndicator provided to the ClockSlaveSync state machine via a PortSyncSync structure. The data type for gmTimeBaseIndicator is UInteger16.

10.2.3.16 lastGmPhaseChange: the most recent value of lastGmPhaseChange provided to the ClockSlaveSync state machine via a PortSyncSync structure. The data type for lastGmPhaseChange is ScaledNs.

10.2.3.17 lastGmFreqChange: the most recent value of lastGmFreqChange provided to the ClockSlaveSync state machine via a PortSyncSync structure. The data type for lastGmFreqChange is Double.

10.2.3.18 localClockTickInterval: the time interval between two successive significant instants (i.e., “ticks”) of the LocalClock entity. The data type for localClockTickInterval is TimeInterval.

10.2.3.19 localTime: the value of currentTime when the most recent ClockSourceTime.invoke function (see 9.2) was received from the ClockSource entity, or when the LocalClock entity most recently updated its time. The data type for localTime is UScaledNs.

10.2.3.20 selectedRole: an Enumeration2 array of length numberPorts+1 (see 8.6.1). selectedRole[j] is set equal to the port role (see Table 10-1) of port whose portNumber is j.

10.2.3.21 masterTime: the time maintained by the ClockMaster entity, based on information received from the ClockSource and LocalClock entities. The data type for masterTime is ExtendedTimestamp.

10.2.3.22 thisClock: the clockIdentity of the current time-aware system. The data type for thisClock is ClockIdentity.

10.2.4 Per-port global variables

10.2.4.1 asCapable: a Boolean that is TRUE if and only if it is determined that this time-aware system and the time-aware system at the other end of the link attached to this port can interoperate with each other via the IEEE 802.1AS protocol. This means that

- a) this time-aware system is capable of executing the IEEE 802.1AS protocol,
- b) the time-aware system at the other end of the link is capable of executing the IEEE 802.1AS protocol, and
- c) there are no non-IEEE-802.1AS systems in between this time-aware system and the time-aware system at the other end of the link that introduce sufficient impairments that the end-to-end time-synchronization performance of B.3 cannot be met.

The determination of asCapable is different for each medium, and is described in the respective media-dependent clauses.

10.2.4.2 syncReceiptTimeoutTimeInterval: the time interval after which sync receipt timeout occurs if time synchronization information has not been received during the interval. The value of syncReceiptTimeoutTimeInterval is equal to syncReceiptTimeout (see 10.6.3.1) multiplied by the syncInterval (see 10.2.4.5) for the port at the other end of the link to which this port is attached. The value of syncInterval for the port at the other end of the link is computed from logMessageInterval of the received Sync message (see 10.5.2.2.11). The data type for syncReceiptTimeoutTimeInterval is UScaledNs.

10.2.4.3 currentLogSyncInterval: the current value of the logarithm to base 2 of the mean time interval, in seconds, between the sending of successive time-synchronization event messages (see 10.6.2.3). This value is set in the LinkDelaySyncIntervalSetting state machine (see 11.2.17). The data type for currentLogSyncInterval is Integer8.

10.2.4.4 initialLogSyncInterval: the initial value of the logarithm to base 2 of the mean time interval, in seconds, between the sending of successive time-synchronization event messages (see 10.6.2.3). The data type for initialLogSyncInterval is Integer8.

10.2.4.5 syncInterval: a variable containing the mean time-synchronization event message transmission interval for the port. This value is set in the LinkDelaySyncIntervalSetting state machine (see 11.2.17). The data type for syncInterval is UScaledNs.

10.2.4.6 neighborRateRatio: the measured ratio of the frequency of the LocalClock entity of the time-aware system at the other end of the link attached to this port, to the frequency of the LocalClock entity of this time-aware system. The data type for neighborRateRatio is Double.

10.2.4.7 neighborPropDelay: the measured propagation delay on the link attached to this port, relative to the LocalClock entity of the time-aware system at the other end of the link (i.e., expressed in the time base of the time-aware system at the other end of the link). The data type for neighborPropDelay is UScaledNs.

10.2.4.8 delayAsymmetry: the asymmetry in the propagation delay on the link attached to this port relative to the grandmaster time base, as defined in 8.3. If propagation delay asymmetry is not modeled, then delayAsymmetry is zero.

10.2.4.9 computeNeighborRateRatio: a Boolean, set by the LinkDelaySyncIntervalSetting state machine (see 11.2.17), that indicates whether neighborRateRatio is to be computed by this port.

10.2.4.10 computeNeighborPropDelay: a Boolean, set by the LinkDelaySyncIntervalSetting state machine (see 11.2.17), that indicates whether neighborPropDelay is to be computed by this port.

10.2.4.11 portEnabled [the term *port* in the following items a) through c) is a physical port]: a Boolean that is set if the time-aware system's MAC Relay Entity and Spanning Tree Protocol Entity can use the MAC Service provided by the Port's MAC entity to transmit and receive frames to and from the attached LAN, i.e., portEnabled is TRUE if and only if:

- a) MAC_Operational (see 6.4.2 of IEEE Std 802.1D-2004) is TRUE; and
- b) Administrative Bridge Port State (see 14.8.2.2 of IEEE Sd 802.1D-2004) for the Port is Enabled; and
- c) AuthControlledPortStatus is Authorized (if the port is a network access port; see IEEE Std 802.1X™-2010 [B5]).

10.2.4.12 pttPortEnabled: a Boolean that is set if the time-synchronization and best master selection functions of the port are enabled.

NOTE—It is expected that the value of pttPortEnabled will be set via the management interface (see 14.6.4). By having both portEnabled and pttPortEnabled variables, a port can be enabled for data transport but not for synchronization transport.

10.2.4.13 thisPort: the portNumber of the current port. The data type for thisPort is UInteger16.

10.2.5 Functions used by multiple state machines

10.2.5.1 random(): returns a uniformly-distributed pseudo-random number whose data type is UInteger16 (i.e., the function returns a uniformly distributed, pseudo-random integer in the range $[0, 2^{16} - 1]$).

10.2.6 SiteSyncSync state machine

10.2.6.1 State machine variables

10.2.6.1.1 rcvdPSSync: a Boolean variable that notifies the current state machine when a PortSyncSync structure (see 10.2.2.3) is received from the PortSyncSyncReceive state machine of a PortSync entity or from the ClockMasterSyncSend state machine of the ClockMaster entity. This variable is reset by this state machine.

10.2.6.1.2 rcvdPSSyncPtr: a pointer to the received PortSyncSync structure indicated by rcvdPSSync.

10.2.6.1.3 txPSSyncPtr: a pointer to the PortSyncSync structure transmitted by the state machine.

10.2.6.2 State machine functions

10.2.6.2.1 setPSSyncSend (rcvdPSSyncIndPtr): creates a PortSyncSync structure to be transmitted, and returns a pointer to this structure. The members are copied from the received PortSyncSync structure pointed to by rcvdPSSyncPtr.

10.2.6.2.2 txPSSync (txPSSyncPtr): transmits a copy of the PortSyncSync structure pointed to by txPSSyncPtr to the PortSyncSyncSend state machine of each PortSync entity and the ClockSlaveSync state machine of the ClockSlave entity of this time-aware system.

10.2.6.3 State diagram

The SiteSyncSync state machine shall implement the function specified by the state diagram in Figure 10-3, the local variables specified in 10.2.6.1, the functions specified in 10.2.6.2, the structure specified in 10.2.2.3, and the relevant global variables and functions specified in 10.2.3 through 10.2.5. The state machine receives time-synchronization information, accumulated rateRatio, and syncReceiptTimeoutTime from the PortSync entity (PortSyncSyncReceive state machine) of the current slave port or from the ClockMaster entity (ClockMasterSyncSend state machine). If the information was sent by a PortSync entity,

the state machine also receives the portIdentity of the port on the upstream time-aware system that sent the information to this time-aware system (if the information was sent by the ClockMaster entity, this portIdentity is zero). The state machine sends a PortSyncSync structure to the PortSync entities of all the ports and to the ClockSlave entity.

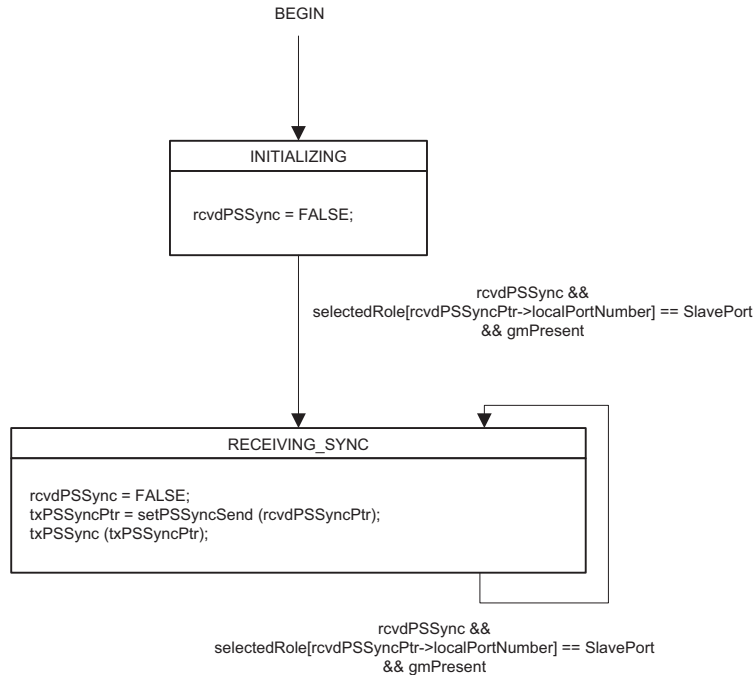

Figure 10-3—SiteSyncSync state machine

10.2.7 PortSyncSyncReceive state machine

10.2.7.1 State machine variables

10.2.7.1.1 rcvdMDSync: a Boolean variable that notifies the current state machine when an MDSyncReceive structure is received from the MDSyncReceiveSM state machine of an MD entity of the same port (see 10.2.2.1). This variable is reset by this state machine.

10.2.7.1.2 rcvdMDSyncPtr: a pointer to the received MDSyncReceive structure indicated by rcvdMDSync.

10.2.7.1.3 txPSSyncPtr: a pointer to the PortSyncSync structure transmitted by the state machine.

10.2.7.1.4 rateRatio: a Double variable that holds the ratio of the frequency of the grandmaster to the frequency of the LocalClock entity. This frequency ratio is computed by (a) measuring the ratio of the grandmaster frequency to the LocalClock frequency at the grandmaster time-aware system and initializing rateRatio to this value in the ClockMasterSend state machine of the grandmaster node, and (b) accumulating, in the PortSyncSyncReceive state machine of each time-aware system, the frequency offset of the LocalClock entity of the time-aware system at the remote end of the link attached to that port to the frequency of the LocalClock entity of this time-aware system.

10.2.7.2 State machine functions

10.2.7.2.1 setPSSyncPSSR (rcvdMDSyncPtr, syncReceiptTimeoutTimeInterval, rateRatio): creates a PortSyncSync structure to be transmitted, and returns a pointer to this structure. The members are set as follows:

- a) localPortNumber is set equal to thisPort,
- b) followUpCorrectionField, sourcePortIdentity, logMessageInterval, and preciseOriginTimestamp are copied from the received MDSyncReceive structure,
- c) upstreamTxTime is set equal to the upstreamTxTime member of the MDSyncReceive structure pointed to by rcvdMDSyncPtr,
- d) syncReceiptTimeoutTime is set equal to currentTime plus syncReceiptTimeoutTimeInterval (see 10.2.4.2), and
- e) the function argument rateRatio is set equal to the local variable rateRatio (computed just prior to invoking setPSSyncReceive (see Figure 10-4). The rateRatio member of the PortSyncSync structure is then set equal to the function argument rateRatio.

10.2.7.2.2 txPSSyncPSSR (txPSSyncPtr): transmits a copy of the PortSyncSync structure pointed to by txPSSyncPtr to the SiteSyncSync state machine of this time-aware system.

10.2.7.3 State diagram

The PortSyncSyncReceive state machine shall implement the function specified by the state diagram in Figure 10-4, the local variables specified in 10.2.7.1, the functions specified in 10.2.7.2, the structures specified in 10.2.2.1 and 10.2.2.3, and the relevant global variables and functions specified in 10.2.3 through 10.2.5. The state machine receives time-synchronization information, accumulated rateRatio, and syncReceiptTimeoutTime from the MD entity (MDSyncReceiveSM state machine) of the same port. The state machine adds, to rateRatio, the fractional frequency offset of the LocalClock entity relative to the LocalClock entity of the upstream time-aware system at the remote end of the link attached to this port. The state machine computes syncReceiptTimeoutTime. The state machine sends this information to the SiteSyncSync entity (SiteSyncSync state machine).

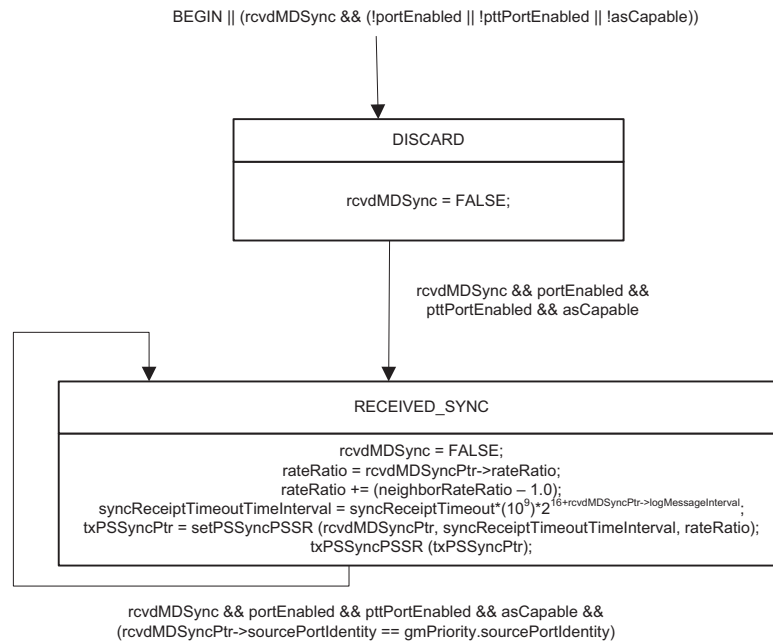

Figure 10-4—PortSyncSyncReceive state machine

10.2.8 ClockMasterSyncSend state machine

10.2.8.1 State machine variables

10.2.8.1.1 syncSendTime: the time in seconds, relative to the LocalClock entity, when synchronization information will next be sent to the SiteSync entity, via a PortSyncSync structure. The data type for syncSendTime is UScaledNs.

10.2.8.1.2 txPSSyncPtr: a pointer to the PortSyncSync structure transmitted by the state machine.

10.2.8.2 State machine functions

10.2.8.2.1 setPSSyncCMSS (gmRateRatio): creates a PortSyncSync structure to be transmitted, and returns a pointer to this structure. The members are set as follows:

- a) localPortNumber is set to 0
- b) preciseOriginTimestamp is set equal to the masterTime, with any fractional nanoseconds truncated
- c) followUpCorrectionField is set equal to the sum of
 - 1) the fractional nanoseconds portion of masterTime.fractionalNanoseconds,
 - 2) the quantity gmRateRatio × (currentTime – localTime)
- d) the clockIdentity member of sourcePortIdentity is set equal to the clockIdentity of this time-aware system
- e) the portNumber member of the sourcePortIdentity is set to 0

NOTE—This quantity and localPortNumber are redundant; both are retained so that the SiteSync entity can process PortSyncSync structures received from a PortSync entity or the ClockMaster entity in the same manner.

- f) logMessageInterval is set to clockMasterLogSyncInterval

- g) upstreamTxTime is set equal to localTime
- h) syncReceiptTimeoutTime is set equal to FFFFFFFF₁₆

NOTE—A ClockMaster entity does not receive Sync messages, and there is no notion of sync receipt timeout. syncReceiptTimeoutTime is set to the largest possible value, approximately 5.84×10^6 years.

- i) rateRatio is set equal to gmRateRatio
- j) gmTimeBaseIndicator is set equal to clockSourceTimeBaseIndicator
- k) lastGmPhaseChange is set equal to clockSourcePhaseOffset, and
- l) lastGmFreqChange is set equal to clockSourceFreqOffset

10.2.8.2.2 txPSSyncCMSS (txPSSyncPtr): transmits a copy of the PortSyncSync structure pointed to by txPSSyncPtr to the SiteSync state machine.

10.2.8.3 State diagram

The ClockMasterSyncSend state machine shall implement the function specified by the state diagram in Figure 10-5, the local variables specified in 10.2.8.1, the functions specified in 10.2.8.2, the structure specified in 10.2.2.3, and the relevant global variables and functions specified in 10.2.3 through 10.2.5. The state machine receives masterTime and clockSourceTimeBaseIndicator from the ClockMasterSyncReceive state machine, and phase and frequency offset between masterTime and syncReceiptTime from the ClockMasterSyncOffset state machine. It provides masterTime (i.e., synchronized time) and the phase and frequency offset to the SiteSync entity via a PortSyncSync structure.

The ClockMasterSyncSend state machine is optional for time-aware systems that are not grandmaster-capable (see 8.6.2.1, 10.1.2, and 10.2.1). This state machine may be present in a time-aware system that is not grandmaster-capable; however, any information supplied by it to the SiteSyncSync state machine is not used by the SiteSyncSync state machine if the time-aware system is not grandmaster-capable.

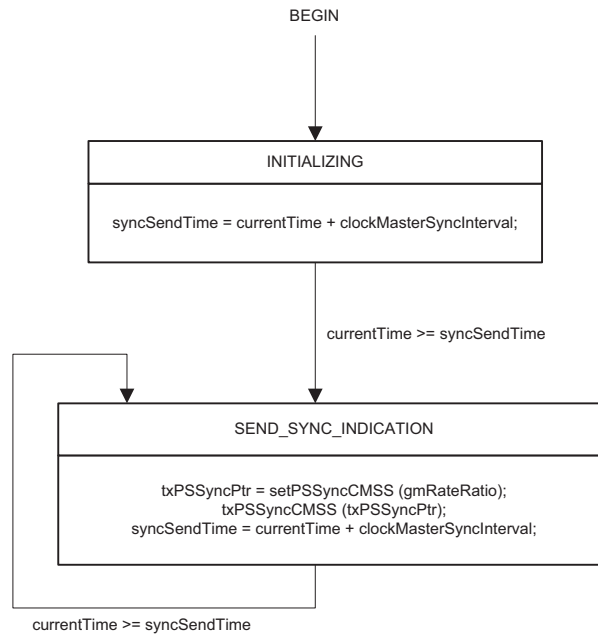

Figure 10-5—ClockMasterSyncSend state machine

10.2.9 ClockMasterSyncOffset state machine

10.2.9.1 State machine variables

10.2.9.1.1 rcvdSyncReceiptTime: a Boolean variable that notifies the current state machine when syncReceiptTime is received from the ClockSlave entity. This variable is reset by this state machine.

10.2.9.2 State machine functions

10.2.9.2.1 computeClockSourceFreqOffset(): computes clockSourceFreqOffset (see 10.2.3.6), using successive values of masterTime computed by the ClockMasterSyncReceive state machine (see 10.2.10) and successive values of syncReceiptTime computed by the ClockSlaveSync state machine (see 10.2.12). Any scheme that uses this information to compute clockSourceFreqOffset is acceptable as long as the performance requirements specified in B.2.4 are met.

NOTE—As one example, clockSourceFreqOffset can be estimated as the ratio of the duration of a time interval measured by the ClockSource entity to the duration of the same time interval computed from networkTime values, minus 1.

10.2.9.3 State diagram

The ClockMasterSyncOffset state machine shall implement the function specified by the state diagram in Figure 10-6, the local variables specified in 10.2.9.1, and the relevant global variables and functions specified in 10.2.3 through 10.2.5. The state machine receives syncReceiptTime from the ClockSlaveSync state machine and masterTime from the ClockMasterSyncReceive state machine. It computes clockSourcePhaseOffset and clockSourceFrequency offset if this time-aware system is not currently the grandmaster, i.e., if selectedRole[0] is equal to PassivePort.

The ClockMasterSyncOffset state machine is optional for time-aware systems that are not grandmaster-capable (see 8.6.2.1, 10.1.2, and 10.2.1). This state machine may be present in a time-aware system that is not grandmaster-capable; however, any information supplied by it, via the ClockMasterSyncSend state machine, to the SiteSyncSync state machine is not used by the SiteSyncSync state machine if the time-aware system is not grandmaster-capable.

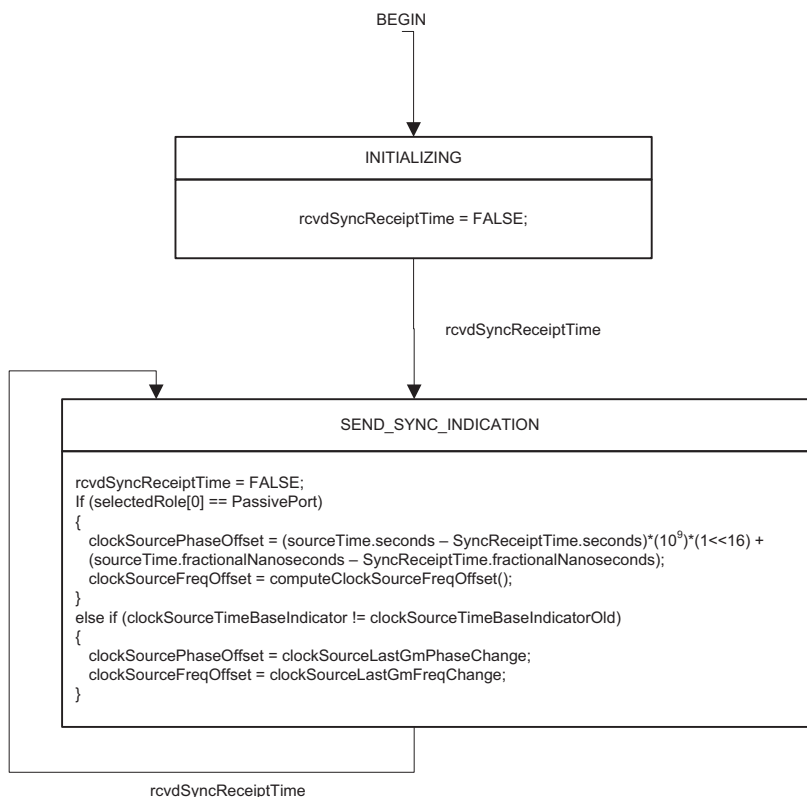

Figure 10-6—ClockMasterSyncOffset state machine

10.2.10 ClockMasterSyncReceive state machine

10.2.10.1 State machine variables

10.2.10.1.1 rcvdClockSourceReq: a Boolean variable that notifies the current state machine when ClockSourceTime.invoke function is received from the Clock source entity. This variable is reset by this state machine.

10.2.10.1.2 rcvdClockSourceReqPtr: a pointer to the received ClockSourceTime.invoke function parameters.

10.2.10.1.3 rcvdLocalClockTick: a Boolean variable that notifies the current state machine when the LocalClock entity updates its time. This variable is reset by this state machine.

10.2.10.2 State machine functions

10.2.10.2.1 computeGmRateRatio(): computes gmRateRatio(see 10.2.3.14), using values of sourceTime conveyed by successive ClockSourceTime.invoke functions (see 9.2.2.1), and corresponding values of

localTime (see 10.2.3.19). Any scheme that uses this information, along with any other information conveyed by the successive ClockSourceTime.invoke functions and corresponding values of localTime, to compute gmRateRatio is acceptable as long as the performance requirements specified in B.2.4 are met.

NOTE—As one example, gmRateRatio can be estimated as the ratio of the elapsed time of the ClockSource entity that supplies time to this time-aware system, to the elapsed time of the LocalClock entity of this time-aware system. This ratio can be computed for the time interval between a received ClockSourceTime.invoke function and a second received ClockSourceTime.invoke function some number of ClockSourceTime.invoke functions later, i.e.,

$$\frac{\text{ClockSourceTime.invoke.sourceTime}_N - \text{ClockSourceTime.invoke.sourceTime}_0}{\text{localTime}_N - \text{localTime}_0}$$

where the successive received ClockSourceTime.invoke functions are indexed from 0 to N , with the first such function indexed as 0, and localTime _{j} is the value of localTime when the ClockSourceTime.invoke function whose index is j is received.

10.2.10.2.2 updateMasterTime(): updates the global variable masterTime (see 10.2.3.21), based on information received from the ClockSource and LocalClock entities. It is the responsibility of the application to filter master times appropriately. As one example, masterTime can be set equal to the sourceTime member of the ClockSourceTime.invoke function when this function is received, and can be incremented by localClockTickInterval (see 10.2.3.18) divided by gmRateRatio (see 10.2.3.14) when rcvdLocalClockTick is TRUE.

10.2.10.3 State diagram

The ClockMasterSyncReceive state machine shall implement the function specified by the state diagram in Figure 10-7, the local variables specified in 10.2.10.1, and the relevant global variables and functions specified in 10.2.3 through 10.2.5. The state machine updates the global variable masterTime with information received from the ClockSource entity via the ClockSourceTime.invoke function and information received from the LocalClock entity. It also computes gmRateRatio, i.e., the ratio of the ClockSource entity frequency and the LocalClock entity frequency.

The ClockMasterSyncReceive state machine is optional for time-aware systems that are not grandmaster-capable (see 8.6.2.1, 10.1.2, and 10.2.1). This state machine may be present in a time-aware system that is not grandmaster-capable; however, any information supplied by it, via the ClockMasterSyncSend state machine, to the SiteSyncSync state machine is not used by the SiteSyncSync state machine if the time-aware system is not grandmaster-capable.

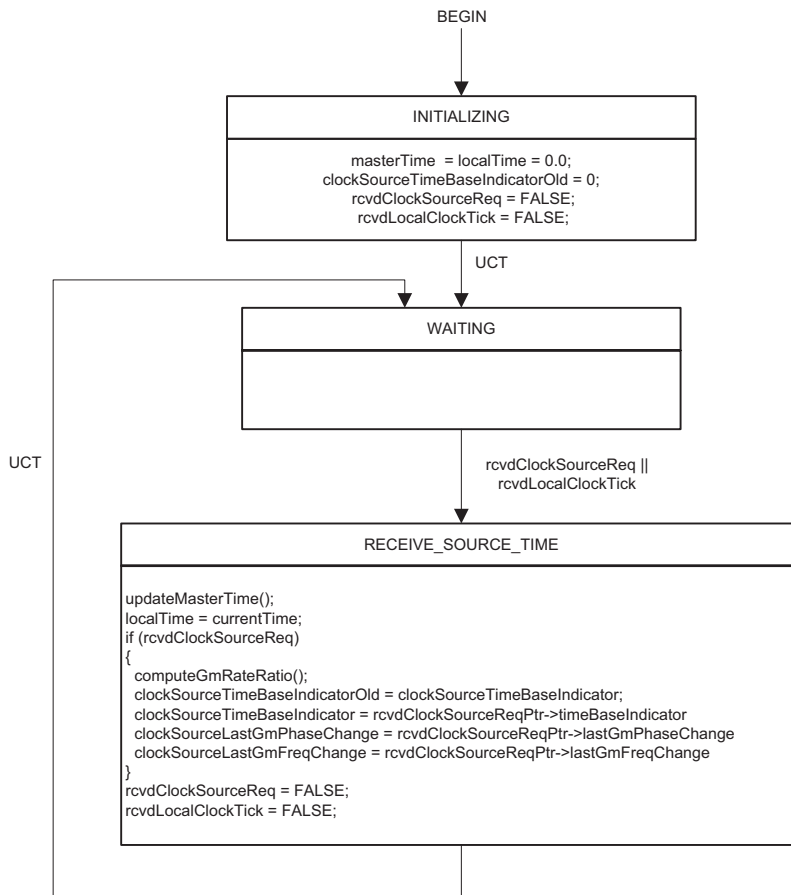

Figure 10-7—ClockMasterSyncReceive state machine

10.2.11 PortSyncSyncSend state machine

10.2.11.1 State machine variables

10.2.11.1.1 rcvdPSSync: a Boolean variable that notifies the current state machine when a PortSyncSync structure is received from the SiteSyncSync state machine of the SiteSync entity of the time-aware system (see 10.2.2.3). This variable is reset by this state machine.

10.2.11.1.2 rcvdPSSyncPtr: a pointer to the received PortSyncSync structure indicated by rcvdPSSync.

10.2.11.1.3 lastSourcePortIdentity: the sourcePortIdentity member of the most recently received PortSyncSync structure. The data type for lastSourcePortIdentity is PortIdentity.

10.2.11.1.4 lastPreciseOriginTimestamp: the preciseOriginTimestamp member of the most recently received PortSyncSync structure. The data type for lastPreciseOriginTimestamp is Timestamp.

10.2.11.1.5 lastFollowUpCorrectionField: the followUpCorrectionField member of the most recently received PortSyncSync member. The data type for lastFollowUpCorrectionField is ScaledNs.

10.2.11.1.6 lastRateRatio: the rateRatio member of the most recently received PortSyncSync structure. The data type for lastRateRatio is Double.

10.2.11.1.7 lastUpstreamTxTime: the upstreamTxTime of the most recently received PortSyncSync member. The data type for lastUpstreamTxTime is UScaledNs.

10.2.11.1.8 lastSyncSentTime: the value of currentTime (i.e., the time relative to the LocalClock entity) when the most recent MDSyncSend structure was sent. The data type for lastSyncSentTime is UScaledNs.

10.2.11.1.9 lastRcvdPortNum: the portNumber of the port on which time-synchronization information was most recently received. The data type for lastReceivedPortNum is UInteger16.

10.2.11.1.10 lastGmTimeBaseIndicator: the gmTimeBaseIndicator of the most recently received PortSyncSync member. The data type for lastGmTimeBaseIndicator is UInteger16.

10.2.11.1.11 lastGmPhaseChange: the lastGmPhaseChange of the most recently received PortSyncSync member. The data type for lastGmPhaseChange is ScaledNs.

10.2.11.1.12 lastGmFreqChange: the lastGmFreqChange of the most recently received PortSyncSync member. The data type for lastGmPhaseChange is Double.

10.2.11.1.13 txMDSyncSendPtr: a pointer to the MDSyncSend structure sent to the MD entity of this port.

10.2.11.1.14 syncReceiptTimeoutTime: the value of the syncReceiptTimeoutTime member of the most recently received PortSyncSync structure. The data type for syncReceiptTimeoutTime is UScaledNs.

10.2.11.2 State machine functions

10.2.11.2.1 setMDSync(): creates an MDSyncSend structure, and returns a pointer to this structure. The members are set as follows:

- a) sourcePortIdentity is set to the portIdentity of this port if the clockIdentity member of lastSourcePortIdentity (see 10.2.11.1.3) is equal to thisClock (see 10.2.3.22); otherwise, it is set to lastSourcePortIdentity
- b) logMessageInterval is set equal to the value of currentLogSyncInterval for this port (see 10.6.2.3)
- c) preciseOriginTimestamp is set equal to lastPreciseOriginTimestamp (see 10.2.11.1.4)
- d) rateRatio is set equal to lastRateRatio (see 10.2.11.1.6)
- e) followUpCorrectionField is set equal to lastFollowUpCorrectionField (see 10.2.11.1.5)
- f) upstreamTxTime is set equal to lastUpstreamTxTime (see 10.2.11.1.7)

10.2.11.2.2 txMDSync(txMDSyncPtr): transmits the MDSyncSend structure pointed to by txMDSyncSendPtr, to the MDSyncSendSM state machine of the MD entity of this port.

10.2.11.3 State diagram

The PortSyncSyncSend state machine shall implement the function specified by the state diagram in Figure 10-8, the local variables specified in 10.2.11.1, the functions specified in 10.2.11.2, the structures specified in 10.2.2.1 through 10.2.2.3, and the relevant global variables and functions specified in 10.2.3 through 10.2.5. The state machine receives time-synchronization information from the SiteSyncSync state machine, corresponding to the receipt of the most recent synchronization information on either the slave port, if this time-aware system is not the grandmaster, or from the ClockMasterSyncSend state machine, if this time-aware system is the grandmaster. The state machine causes time-synchronization information to be sent to the MDSyncSendSM state machine if this port is a MasterPort.

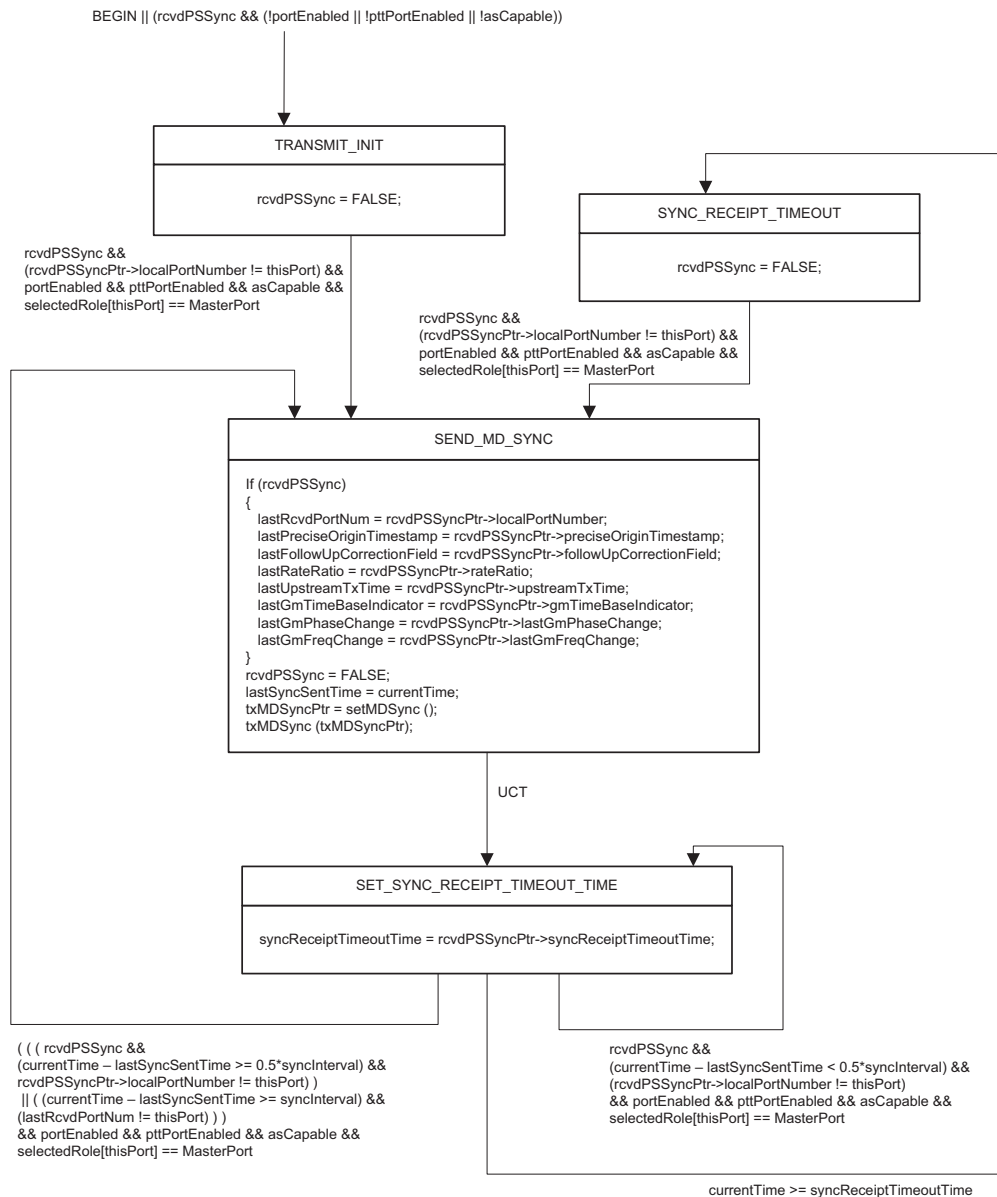

Figure 10-8—PortSyncSyncSend state machine

10.2.12 ClockSlaveSync state machine

10.2.12.1 State machine variables

10.2.12.1.1 rcvdPSSync: a Boolean variable that notifies the current state machine when a PortSyncSync structure is received from the SiteSyncSync state machine of the SiteSync entity. This variable is reset by this state machine.

10.2.12.1.2 rcvdLocalClockTick: a Boolean variable that notifies the current state machine when the LocalClock entity updates its time. This variable is reset by this state machine.

10.2.12.1.3 revdPSSyncPtr: a pointer to the received PortSyncSync structure.

10.2.12.2 State machine functions

10.2.12.2.1 updateSlaveTime(): updates the global variable clockSlaveTime (see 10.2.3.3), based on information received from the SiteSync and LocalClock entities. It is the responsibility of the application to filter slave times appropriately (see B.3 and B.4 for examples). As one example, clockSlaveTime can be incremented by localClockTickInterval (see 10.2.3.18) divided by rateRatio member of the received PortSyncSync structure. If no time-aware system is grandmaster-capable, i.e., gmPresent is FALSE, then clockSlaveTime is set to the time provided by the LocalClock. This function is invoked when revdLocalClockTick is TRUE.

10.2.12.2.2 invokeApplicationInterfaceFunction (functionName): invokes the application interface function whose name is functionName. In the case here, functionName is clockTargetPhaseDiscontinuity.result (see 9.6.2).

10.2.12.3 State diagram

The ClockSlaveSync state machine shall implement the function specified by the state diagram in Figure 10-9, the local variables specified in 10.2.12.1, and the relevant global variables and functions specified in 10.2.3 through 10.2.5. The state machine receives a PortSyncSync structure from the SiteSyncSync state machine. It computes syncReceiptTime and clockSlaveTime, and sets syncReceiptLocalTime (i.e., the time relative to the LocalClock entity corresponding to syncReceiptTime), GmTimeBaseIndicator, lastGmPhaseChange, and lastGmFreqChange. It provides clockSlaveTime to the ClockMasterSyncOffset state machine, and provides information to the ClockTarget entity (via the ClockTargetPhaseDiscontinuity interface, see 9.6) to enable that entity to determine if a phase or frequency discontinuity has occurred.

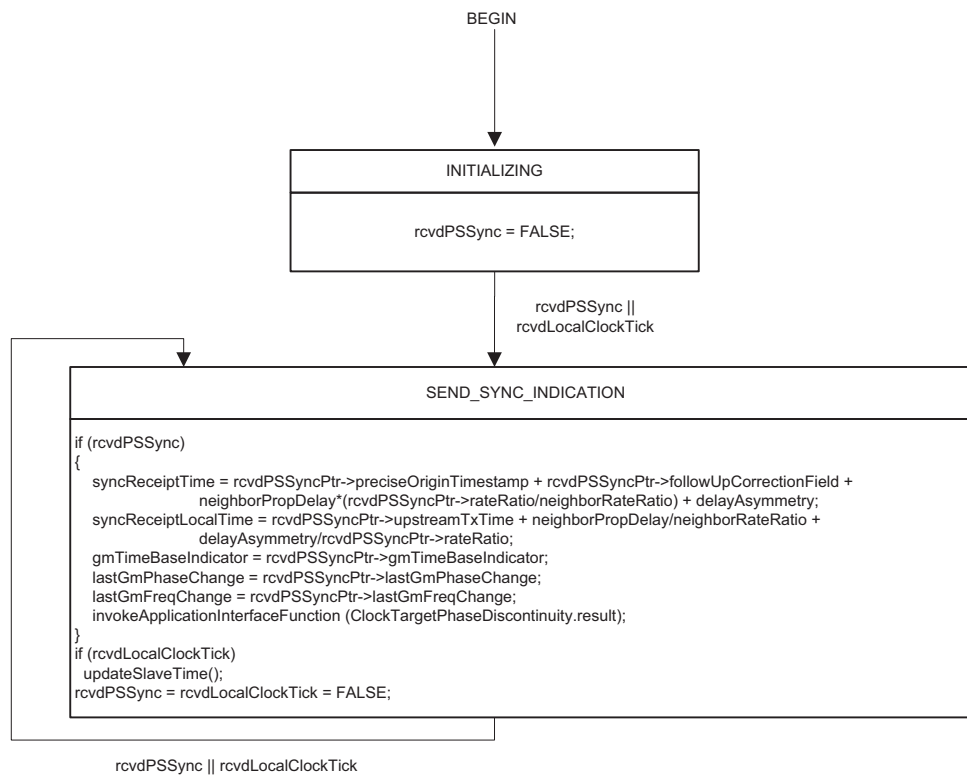

Figure 10-9—ClockSlaveSync state machine

10.3 Best master clock selection and announce interval setting state machines

10.3.1 Best master clock algorithm overview

The BMCA determines the grandmaster for a gPTP domain and constructs a time-synchronization spanning tree with the grandmaster as the root. Synchronized time is transported from the grandmaster to other time-aware systems via the time-synchronization spanning tree. Best master selection information is exchanged between time-aware systems via Announce messages (see 10.4 and 10.5). Each Announce message contains time-synchronization spanning tree vector information that identifies one time-aware system as the root of the time-synchronization spanning tree and, if the time-aware system is grandmaster-capable, the grandmaster. Each time-aware system in turn uses the information contained in the Announce messages it receives, along with its knowledge of itself, to compute which of the time-aware systems that it has knowledge of should be the root and, if grandmaster-capable, the grandmaster.

Once an Announce message is transmitted by a port, subsequent timing information (see 7.4) transmitted by that port shall be derived from the grandmaster indicated in that Announce message.

As part of constructing the time-synchronization spanning tree, each port of each time-aware system is assigned a port role from Table 10-1 by state machines associated with the ports and with the time-aware system as a whole.

Table 10-1—Port role definitions

Port role	Description
MasterPort	Any port, P, of the time-aware system that is closer to the root than any other port of the gPTP communication path connected to P
SlavePort	The one port of the time-aware system that is closest to the root time-aware system. If the root is grandmaster-capable, the SlavePort is also closest to the grandmaster. The time-aware system does not transmit Sync or Announce messages on the SlavePort.
PassivePort	Any port of the time-aware system whose port role is not MasterPort, SlavePort, or DisabledPort.
DisabledPort	Any port of the time-aware system for which portEnabled, pttPortEnabled, and asCapable are not all TRUE.

NOTE 1—Information contained in Sync and associated Follow_Up messages received on ports whose port role is PassivePort is discarded; the SiteSyncSync state machine (see 10.2.6) uses only information received from a port whose port role is SlavePort.

An example master/slave hierarchy of time-aware systems is shown in Figure 10-10. The grandmaster ports all have port role of MasterPort. All the other time-aware systems have exactly one slave port. The time-synchronization spanning tree is formed by the time-aware systems and the links that do not have an endpoint port whose port role is PassivePort.

NOTE 2—The BMCA described in this standard is equivalent to a subset of the BMCA described in IEEE Std 1588-2008. It is also equivalent to a subset of the Rapid Spanning Tree Protocol (RSTP) described in IEEE Std 802.1D-2004 (though the full RSTP described in the latter standard is not equivalent to the full BMCA described in the former standard). The BMCA description here uses the formalism of the RSTP description in the latter standard.

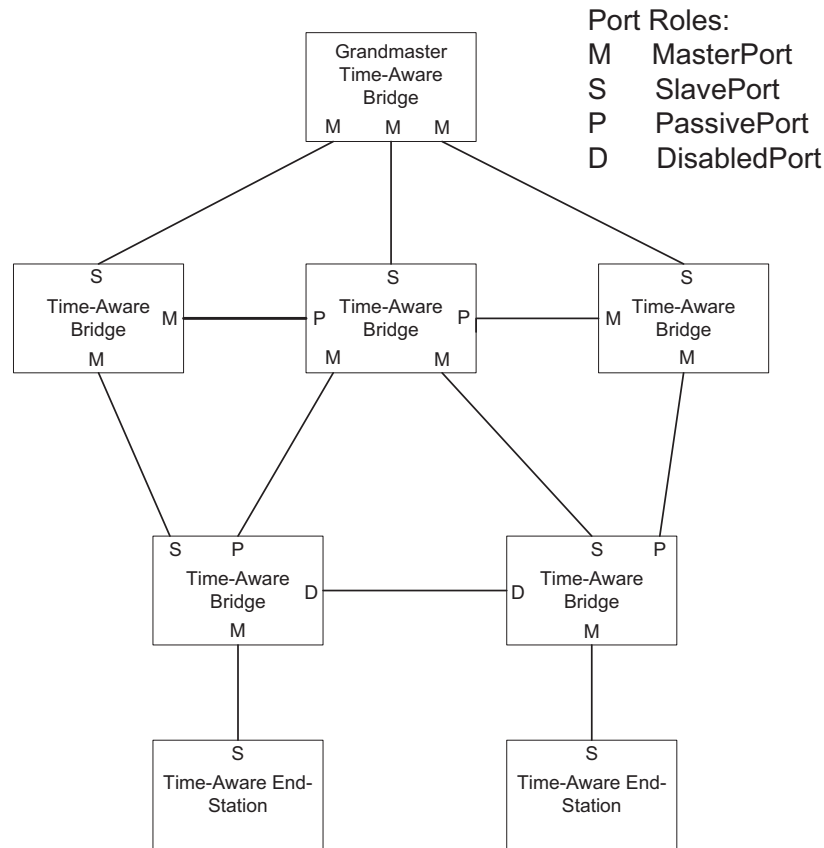

Figure 10-10—Example master/slave hierarchy of time-aware systems

10.3.2 systemIdentity

The systemIdentity attribute of a time-aware system is a UInteger112 (i.e., a 14-byte, unsigned integer) formed by concatenating the following attributes, in the following order, from most significant to least significant bit:

- a) priority1 (1 octet, see 8.6.2.1)
- b) clockClass (1 octet, see 8.6.2.2 and 6.3.3.8)
- c) clockAccuracy (1 octet, see 8.6.2.3 and 6.3.3.8)
- d) offsetScaledLogVariance (2 octets, see 8.6.2.4 and 6.3.3.8)
- e) priority2 (1 octet, see 8.6.2.5)
- f) clockIdentity (8 octets, see 8.5.2.2 and 6.3.3.6)

The systemIdentity attribute is defined for convenience when comparing two time-aware systems to determine which is a better candidate for root and if the time-aware system is grandmaster-capable (i.e., the value of priority1 is less than 255, see 8.6.2.1). Two time-aware systems are compared as follows. Let the systemIdentity of time-aware system A be S_A and the systemIdentity of time-aware system B be S_B . Let the clockIdentity of A be C_A and the clockIdentity of B be C_B . Then, if $C_A \neq C_B$, i.e., A and B represent different time-aware systems:

- g) A is better than B if and only if $S_A < S_B$, and

- h) B is better than A if and only if $S_B < S_A$.

If $C_A = C_B$, i.e., A and B represent the same time-aware system:

- i) $S_A < S_B$ means that A represents an upgrading of the time-aware system compared to B or, equivalently, B represents a downgrading of the time-aware system compared to A,
- j) $S_B < S_A$ means that B represents an upgrading of the time-aware system compared to A or, equivalently, A represents a downgrading of the time-aware system compared to B, and
- k) $S_A = S_B$ means that A and B represent the same time-aware system that has not changed.

Comparisons g) and h) above imply that, with the ordering of attributes in the systemIdentity, the clockIdentity is a tie-breaker for the case where two different time-aware systems that have identical attributes a) through e) are compared.

Comparisons g) and h) also imply that a time-aware system that is grandmaster-capable is always better than another time-aware system that is not grandmaster-capable, because the priority1 is less than 255 if the time-aware system is grandmaster-capable and 255 if it is not grandmaster-capable (see 8.6.2.1).

The cases where A and B represent different time-aware systems and represent the same time-aware system are handled separately in the BMCA. When comparing two different time-aware systems, the better time-aware system is selected as the grandmaster candidate. However, if A and B represent the same time-aware system with attributes that have changed, the time-aware system is considered as having the most recent attributes when doing subsequent comparisons with other time-aware systems.

10.3.3 stepsRemoved

Every time-aware system has a stepsRemoved associated with it. For the root time-aware system, and therefore the grandmaster in the case where the root is grandmaster-capable, it is zero. For all other time-aware systems, it is the number of links in the path from the root to the respective time-aware system.

The port on each time-aware system with the lowest stepsRemoved is assigned the role of SlavePort for that time-aware system (the root time-aware system does not have a SlavePort). This lowest stepsRemoved is also considered the stepsRemoved for the time-aware system. If a time-aware system has two or more ports with the same stepsRemoved, then the port with the smallest portNumber is selected as the SlavePort.

Each gPTP communication path in the network also has an associated stepsRemoved. This is the stepsRemoved of the lowest stepsRemoved time-aware system with a port attached to that communication path. That time-aware system is selected as the master time-aware system for that communication path. Every communication path has exactly one port whose role is MasterPort; the time-aware system of that port is the master time-aware system for that communication path. If there are two or more time-aware systems attached to the communication path with the same stepsRemoved, then the better of the two time-aware systems as determined by the systemIdentity is selected as the master time-aware system.

10.3.4 time-synchronization spanning tree priority vectors

Time-aware systems send best master selection information to each other in Announce messages. The information may be structured in a time-synchronization spanning tree priority vector. time-synchronization spanning tree priority vectors provide the basis for a concise specification of the BMCA's determination of the time-synchronization spanning tree and grandmaster. A priority vector is formed by concatenating the following attributes, in the following order, from most significant to least significant bit:

- a) rootSystemIdentity (14 octets, see 10.3.2)
- b) stepsRemoved (2 octets, see 10.3.3)

- c) sourcePortIdentity (i.e., portIdentity of the transmitting time-aware system; 10 octets, see 8.5.2 and 10.5.2)
- d) portNumber of the receiving port (2 octets, see 8.5.2.3)

The first two components of a priority vector are significant throughout the gPTP domain; they are propagated via Announce messages and updated through invocation of BMCA state machines. The next component is locally significant; it is assigned hop by hop for each communication path or time-aware system and used as a tie-breaker in decisions between time-synchronization spanning tree priority vectors that are otherwise equal. The fourth component is not conveyed in Announce messages, but is used as a tie-breaker within a time-aware system.

The set of all time-synchronization spanning tree priority vectors is totally ordered. For all components, a lesser numerical value is better, and earlier components in the preceding list are more significant. In addition, as mentioned earlier, a priority vector that reflects a root time-aware system that is grandmaster-capable is always better than a priority vector that reflects a root time-aware system that is not grandmaster-capable. As each time-aware system port receives a priority vector, via an Announce message, from ports closer to the root, additions are made to one or more components to yield a worse priority vector. This process of receiving information, adding to it, and passing it on, can be described in terms of the message priority vector received and a set of priority vectors used to facilitate the computation of a priority vector for each port, to be transmitted in further Announce Messages to time-aware systems further from the root.

10.3.5 Priority vector calculations

The portPriorityVector is the time-synchronization spanning tree priority vector held for the port when the reception of Announce messages and any pending update of information has been completed:

$$\text{portPriorityVector} = \{\text{rootSystemIdentity} : \text{stepsRemoved} : \text{sourcePortIdentity} : \text{portNumber}\}$$

A messagePriorityVector is the time-synchronization spanning tree priority vector conveyed in a received Announce Message. For a time-aware system S receiving an Announce Message on Port P_S with portNumber PN_S, from a MasterPort with portIdentity P_M on time-aware system M claiming a rootSystemIdentity of R_M and a stepsRemoved of SR_M:

$$\text{messagePriorityVector} = \{R_M : SR_M : P_M : PN_S\}$$

This messagePriorityVector is superior to the portPriorityVector and will replace it if, and only if, the messagePriorityVector is better than the portPriorityVector, or the Announce message has been transmitted from the same master time-aware system and MasterPort as the portPriorityVector, i.e., if the following is true:

$$\begin{aligned} & ((R_M < \text{rootSystemIdentity})) || \\ & ((R_M == \text{rootSystemIdentity}) \ \&\& \ (SR_M < \text{stepsRemoved})) || \\ & ((R_M == \text{rootSystemIdentity}) \ \&\& \ (SR_M == \text{stepsRemoved}) \ \&\& \ (P_M < \text{sourcePortIdentity (of current master time-aware system)})) || \\ & ((R_M == \text{rootSystemIdentity}) \ \&\& \ (SR_M == \text{stepsRemoved}) \\ & \ \&\& \ (P_M == \text{sourcePortIdentity (of current master time-aware system)}) \ \&\& \ (PN_S < \text{portNumber})) || \\ & ((P_M.\text{clockIdentity} == \text{sourcePortIdentity.clockIdentity (of current master time-aware system)}) \ \&\& \\ & \ (P_M.\text{portNumber} == \text{sourcePortIdentity.PortNumber (of the current master time-aware system)})) || \end{aligned}$$

A `gmPathPriorityVector` can be calculated from a received `portPriorityVector` by adding one to the `stepsRemoved` component:

$$\text{gmPathPriorityVector} = \{R_M : SR_M + 1 : P_M : PN_S\}$$

The `systemPriorityVector` for a time-aware system S with `systemIdentity` S_S and `clockIdentity` C_S is the priority vector that would, with the `portIdentity` of the `SlavePort` set equal to the `portIdentity` of the transmitting port, be used as the message priority vector in Announce Messages transmitted on S 's ports whose role is `MasterPort` if S was selected as the root:

$$\text{systemPriorityVector} = \{S_S : 0 : \{C_S : 0\} : 0\}$$

The `gmPriorityVector` for S is the best of the set comprising the `systemPriorityVector` vector plus every `gmPathPriorityVector` for which the `clockIdentity` of the master time-aware system `portIdentity` is not the `clockIdentity` of S . If the `systemPriorityVector` is best, S has been selected as the root. For the case where the best `gmPathPriorityVector` is that of port PN_S above, then:

$$\text{gmPriorityVector} = \{S_S : 0 : \{C_S : 0\} : 0\} \text{ if } S \text{ is better than } R_M, \text{ or}$$

$$\text{gmPriorityVector} = \{R_M : SR_M + 1 : P_M : PN_S\} \text{ if } S \text{ is worse than } R_M.$$

The `masterPriorityVector` for a port Q on time-aware system S is the `gmPriorityVector` with S 's `clockIdentity` C_S substituted for the `clockIdentity` of the master `portIdentity`, and Q 's `portNumber` PN_Q substituted for the `portNumber` of the master `portIdentity` and for the `portNumber` of the receiving port:

$$\begin{aligned} \text{masterPriorityVector} &= \{S_S : 0 : \{C_S : PN_Q\} : PN_Q\} \text{ if } S \text{ is better than } R_M, \text{ or} \\ \text{masterPriorityVector} &= \{R_M : SR_M + 1 : \{C_S : PN_Q\} : PN_Q\} \text{ if } S \text{ is worse than } R_M. \end{aligned}$$

If the `masterPriorityVector` is better than the `portPriorityVector`, the port will be the `MasterPort` for the attached communication path and the `portPriorityVector` will be updated. The `messagePriorityVector` information in Announce messages transmitted by a port always includes the first three components of the `masterPriorityVector` of the port.

NOTE—The consistent use of lower numerical values to indicate better information is deliberate as the `MasterPort` that is closest to the root, i.e., has a numerically lowest path cost component, is selected from amongst potential alternatives for any given communication path. Adopting the conventions that lower numerical values indicate better information, that where possible more significant priority components are encoded earlier in the octet sequence of an Announce message, and that earlier octets in the encoding of individual components are more significant, allow concatenated octets that compose a priority vector to be compared as if they were a multiple octet encoding of a single number, without regard to the boundaries between the encoded components. To reduce the confusion that naturally arises from having the lesser of two numerical values represent the better of the two, i.e., the one to be chosen all other factors being equal, this clause uses the following consistent terminology. Relative numeric values are described as “least,” “lesser,” “equal,” and “greater,” and their comparisons as “less than,” “equal to,” or “greater than,” while relative time-synchronization spanning tree priorities are described as “best,” “better,” “the same,” “different,” and “worse” and their comparisons as “better than,” “the same as,” “different from,” and “worse than.” The operators “<” and “=” represent less than and equal to respectively. The terms “superior” and “inferior” are used for comparisons that are not simply based on priority but can include the fact that the priority vector of a `MasterPort` can replace an earlier vector transmitted in an Announce message by the same port.

10.3.6 Port role assignments

The BMCA assigns one of the following port roles to each time-aware system Port: `MasterPort`, `SlavePort`, `PassivePort`, or `DisabledPort`.

The `DisabledPort` role is assigned if `portEnabled` is FALSE (see 10.2.4.11), `pttPortEnabled` is FALSE (see 10.2.4.12), or `asCapable` is FALSE (see 10.2.4.1).

A port for which `portEnabled`, `pttPortEnabled`, and `asCapable` are all TRUE has its port role assigned according to the source and relative priority of the time-synchronization spanning tree `portPriorityVector` (see 10.3.4 and 10.3.5) as follows:

- a) If the time-aware system is not the root, the source of the `gmPriorityVector` is the `SlavePort`.
- b) Each port whose `portPriorityVector` is its `masterPriorityVector` is a `MasterPort`.
- c) Each Port, other than the `SlavePort`, whose `portPriorityVector` has been received from another time-aware system or another port on this time-aware system is a `PassivePort`.

10.3.7 Overview of best master clock selection and announce interval setting state machines

The best master clock selection function in a time-aware system is specified by a number of cooperating state machines. Figure 10-11 is not itself a state machine, but illustrates the machines, their interrelationships, the principle variables and structures used to communicate between them, their local variables, and performance parameters.

NOTE—The BMCA state machines are all invoked by the media-independent layer, i.e., by the `SiteSync` and `PortSync` entities. The media-dependent layer, i.e., the MD entity, simply takes an `Announce` message received from the `PortSync` entity of the same port and gives it to the next lower layer (e.g., IEEE 802.3, IEEE 802.11). It is the `PortSync` entity that generates and consumes `Announce` messages.

The media-independent layer state machines in Figure 10-2 are:

- a) `PortAnnounceReceive` (one instance per port): receives `Announce` information from the MD entity of the same port, determines if the `Announce` message is qualified and, if so, sets the `rcvdMsg` variable. This state machine is invoked by the `PortSync` entity of the port.
- b) `PortAnnounceInformation` (one instance per port): receives new qualified `Announce` information from the `PortAnnounceReceive` state machine, determines if the `Announce` information is better than the current best master information it knows about, and updates the current best master information when it receives updated port role information from the `PortRoleSelection` state machine and when announce receipt timeout or, in the case where `gmPresent` is TRUE, sync receipt timeout occurs. This state machine is invoked by the `PortSync` entity of the port.
- c) `PortRoleSelection` (one instance per time-aware system): updates the `gmPathPriority` vector for each port of the time-aware system, the `gmPriorityVector` for the time-aware system, and the `masterPriorityVector` for each port of the time-aware system; determines the port role for each port; and updates `gmPresent`. This state machine is invoked by the `SiteSync` entity of the time-aware system.
- d) `PortAnnounceTransmit` (one instance per port): transmits `Announce` information to the MD entity when an announce interval has elapsed, port roles have been updated, and `portPriority` and `portStepsRemoved` information has been updated with newly determined `masterPriority` and `masterStepsRemoved` information. This state machine is invoked by the `PortSync` entity of the port.

An additional state machine, the `AnnounceIntervalSetting` state machine, receives a `Signaling` message that contains a `Message Interval Request TLV` (see 10.5.4.3), and sets the global variables that give the duration of the mean interval between successive `Announce` messages.

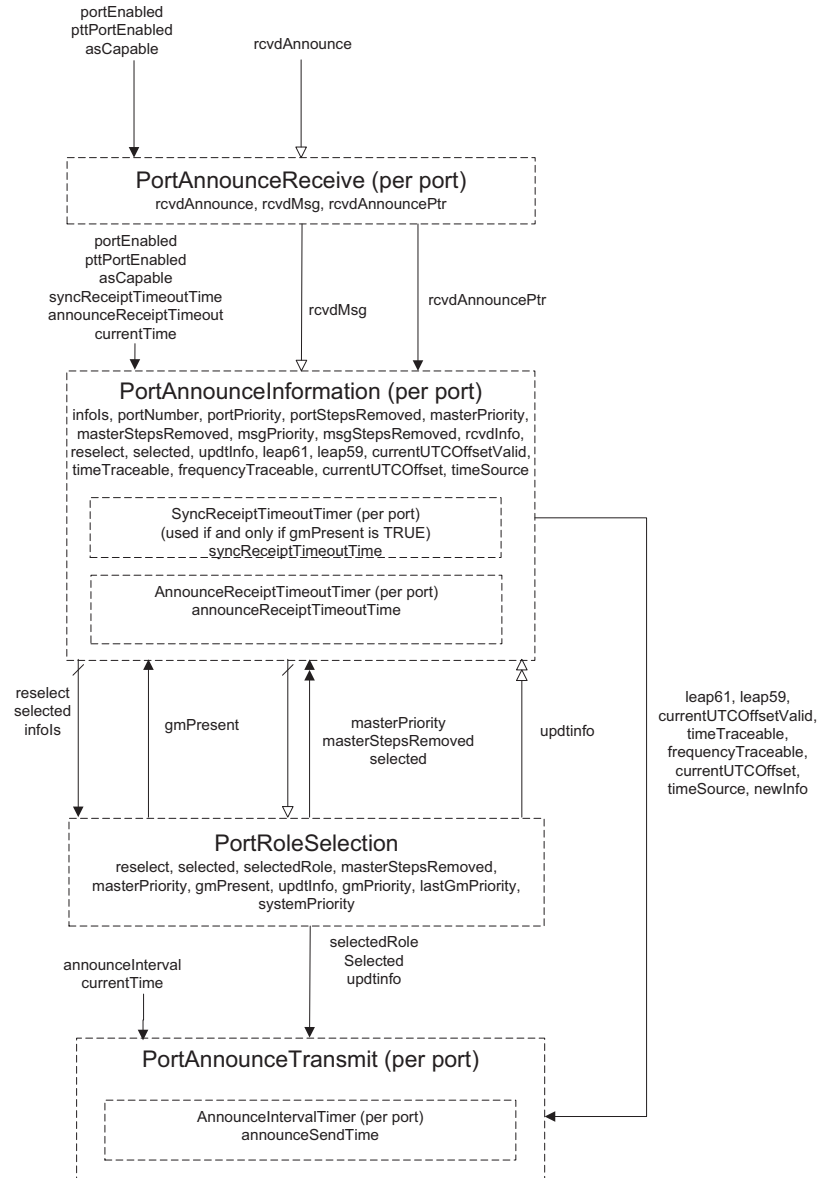

Notation:

Variables are shown both within the machine where they are principally used and between machines where they are used to communicate information. In the latter case a variety of arrow styles, running from one machine to another, show how each is typically used:

- Not changed by the target machine. Where the machines are both per Port, this variable communicates between instances for the same port
- ▷ Set (or cleared) by the originating machine, cleared (or set) by the target machine. Where the machines are both per Port, this communicates between instances for the same port.
- ▶▶ As above, except that the originating per port machine instance communicates with multiple port machine instances (by setting or clearing variables owned by those ports).
- ▷▷ As above, except that multiple per Port instances communicate with (an) other instance(s) (by setting or clearing variables owned by the originating ports).

Figure 10-11—Best master clock selection state machines—overview and interrelationships

10.3.8 Per-time-aware system global variables

10.3.8.1 reselect: a Boolean array of length `numberPorts` (see 8.6.1). Setting `reselect[j]`, where $0 \leq j \leq \text{numberPorts}$, to `TRUE` causes the `ROLE_SELECTION` block of the `PortRoleSelection` state machine (see 10.3.12) to be re-entered, which in turn causes the port role of each port of the time-aware system to be updated (via the function `updateRolesTree()`, see 10.3.12.1.4).

10.3.8.2 selected: a Boolean array of length `numberPorts` (see 8.6.1). `selected[j]`, where $0 \leq j \leq \text{numberPorts}$, is set to `TRUE` immediately after the port roles of all the ports are updated. This indicates to the `PortAnnounceInformation` state machine (see 10.3.11) that it can update the `portPriorityVector` and other variables for each port.

10.3.8.3 masterStepsRemoved: the value of `stepsRemoved` for the time-aware system, after the port roles of all the ports have been updated (see 10.3.12.1.4 for details on the computation of `masterStepsRemoved`).

10.3.8.4 leap61: a Boolean variable whose value is `TRUE` if the last minute of the current UTC day, relative to the current grandmaster, contains 61 s, and `FALSE` if the last minute of the current UTC day does not contain 61 s.

10.3.8.5 leap59: a Boolean variable whose value is `TRUE` if the last minute of the current UTC day, relative to the current grandmaster, contains 59 s, and `FALSE` if the last minute of the current UTC day does not contain 59 s.

10.3.8.6 currentUtcOffsetValid: a Boolean variable whose value is `TRUE` if `currentUtcOffset` (see 10.3.8.9), relative to the current grandmaster, is known to be correct, and `FALSE` if `currentUtcOffset` is not known to be correct.

10.3.8.7 timeTraceable: a Boolean variable whose value is `TRUE` if both `clockSlaveTime` (i.e., the synchronized time maintained at the slave, see 10.2.3.3) and `currentUtcOffset` (see 10.3.8.9) relative to the current grandmaster are traceable to a primary reference, and `FALSE` if one or both are not traceable to a primary reference.

10.3.8.8 frequencyTraceable: a Boolean variable whose value is `TRUE` if the frequency that determines `clockSlaveTime`, i.e., the frequency of the `LocalClockEntity` multiplied by the most recently computed `rateRatio` by the `PortSyncSyncReceive` state machine (see 10.2.7.1.4), is traceable to a primary reference, and `FALSE` if this frequency is not traceable to a primary reference.

10.3.8.9 currentUtcOffset: the difference between TAI time and UTC time, i.e., TAI time minus UTC time, expressed in seconds, and relative to the current grandmaster. The data type for `currentUtcOffset` is `Integer16`.

NOTE—For example, 2006-01-01 00:00:00 UTC and 2006-01-01 00:00:33 TAI represent the same instant of time. At this time, `currentUtcOffset` was equal to 33 s.¹⁴

10.3.8.10 timeSource: the value of the `timeSource` attribute of the current grandmaster (see 8.6.2.7). The data type for `timeSource` is `Enumeration8`.

10.3.8.11 sysLeap61: a Boolean variable whose value is `TRUE` if the last minute of the current UTC day, relative to the `ClockMaster` entity of this time-aware system, contains 61 s, and `FALSE` if the last minute of the current UTC day does not contain 61 s.

¹⁴Note also that a leap second was not added at the end of the last UTC minute of 2005-12-31.

10.3.8.12 sysLeap59: a Boolean variable whose value is TRUE if the last minute of the current UTC day, relative to the ClockMaster entity of this time-aware system, contains 59 s, and FALSE if the last minute of the current UTC day does not contain 59 s.

10.3.8.13 sysCurrentUTCOffsetValid: a Boolean variable whose value is TRUE if currentUtcOffset (see 10.3.8.9), relative to the ClockMaster entity of this time-aware system, is known to be correct, and FALSE if currentUtcOffset is not known to be correct.

10.3.8.14 sysTimeTraceable: a Boolean variable whose value is TRUE if both masterTime (i.e., the time maintained by the ClockMaster entity of this time-aware system, see 10.2.3.21) and currentUtcOffset (see 10.3.8.9) relative to the ClockMaster entity of this time-aware system, are traceable to a primary reference, and FALSE if one or both are not traceable to a primary reference.

10.3.8.15 sysFrequencyTraceable: a Boolean variable whose value is TRUE if the frequency that determines masterTime of the ClockMaster entity of this time-aware system, i.e., the frequency of the LocalClockEntity multiplied by the most recently computed gmRateRatio by the ClockMasterSyncReceive state machine (see 10.2.3.14 and 10.2.10), is traceable to a primary reference, and FALSE if this frequency is not traceable to a primary reference.

10.3.8.16 sysCurrentUtcOffset: the difference between TAI time and UTC time, i.e., TAI time minus UTC time, expressed in seconds, and relative to the ClockMaster entity of this time-aware system. The data type for currentUtcOffset is Integer16.

NOTE—See the NOTE in 10.3.8.9 for more detail on the sign convention.

10.3.8.17 sysTimeSource: the value of the timeSource attribute of the ClockMaster entity of this time-aware system (see 8.6.2.7). The data type for timeSource is Enumeration8.

10.3.8.18 systemPriority: the systemPriority vector for this time-aware system. The data type for masterPriority is UInteger224 (see 10.3.4).

10.3.8.19 gmPriority: the current gmPriorityVector for the time-aware system. The data type for masterPriority is UInteger224 (see 10.3.4).

10.3.8.20 lastGmPriority: the previous gmPriorityVector for the time-aware system, prior to the most recent invocation of the PortRoleSelection state machine. The data type for masterPriority is UInteger224 (see 10.3.4).

10.3.8.21 pathTrace: an array that contains the clockIdentities of the successive time-aware systems that receive, process, and send Announce messages. The data type for pathTrace is ClockIdentity[N], where N is the number of time-aware systems, including the grandmaster, that the Announce information has traversed.

NOTE—N is equal to stepsRemoved+1 (see 10.5.3.2.6). The size of the pathTrace array can change after each reception of an Announce message.

10.3.9 Per-port global variables

10.3.9.1 announceReceiptTimeoutTimeInterval: the time interval after which announce receipt timeout occurs if an Announce message has not been received during the interval. The value of announceReceiptTimeoutTimeInterval is equal to announceReceiptTimeout (see 10.6.3.2) multiplied by the announceInterval (see 10.3.9.6) for the port at the other end of the link to which this port is attached. The value of announceInterval for the port at the other end of the link is computed from logMessageInterval of the received Announce message (see 10.5.2.2.11). The data type for announceReceiptTimeoutTimeInterval is UScaledNs.

10.3.9.2 infoIs: an Enumeration2 that takes the values Received, Mine, Aged, or Disabled, to indicate the origin and state of the port's time-synchronization spanning tree information:

- a) If infoIs is Received, the port has received current information (i.e., announce receipt timeout has not occurred and, if gmPresent is TRUE, sync receipt timeout also has not occurred) from the master time-aware system for the attached communication path.
- b) If infoIs is Mine, information for the port has been derived from the SlavePort for the time-aware system (with the addition of SlavePort stepsRemoved). This includes the possibility that the SlavePort is the port whose portNumber is 0, i.e., the time-aware system is the root of the gPTP domain.
- c) If infoIs is Aged, announce receipt timeout or, in the case where gmPresent is TRUE, sync receipt timeout have occurred.
- d) If portEnabled, pttPortEnabled, and asCapable are not all TRUE, infoIs is Disabled.

10.3.9.3 masterPriority: the masterPriorityVector for the port. The data type for masterPriority is UInteger224 (see 10.3.4).

10.3.9.4 currentLogAnnounceInterval: the current value of the logarithm to base 2 of the mean time interval, in seconds, between the sending of successive Announce messages (see 10.6.2.2). This value is set in the AnnounceIntervalSetting state machine (see 10.3.14). The data type for currentLogAnnounceInterval is Integer8.

10.3.9.5 initialLogAnnounceInterval: the initial value of the logarithm to base 2 of the mean time interval, in seconds, between the sending of successive Announce messages (see 10.6.2.2). The data type for initialLogAnnounceInterval is Integer8.

10.3.9.6 announceInterval: a variable containing the mean Announce message transmission interval for the port. This value is set in the AnnounceIntervalSetting state machine (see 10.3.14). The data type for announceInterval is UScaledNs.

10.3.9.7 messageStepsRemoved: the value of stepsRemoved contained in the received Announce information. The data type for messageStepsRemoved is UInteger16.

10.3.9.8 newInfo: a Boolean variable that is set to cause a port to transmit Announce information; specifically, it is set when an announce interval has elapsed (see Figure 10-15), port roles have been updated, and portPriority and portStepsRemoved information has been updated with newly determined masterPriority and masterStepsRemoved information.

10.3.9.9 portPriority: the portPriorityVector for the port. The data type for portPriority is UInteger224 (see 10.3.4).

10.3.9.10 portStepsRemoved: the value of stepsRemoved for the port. portStepsRemoved is set equal to masterStepsRemoved (see 10.3.8.3) after masterStepsRemoved is updated. The data type for portStepsRemoved is UInteger16.

10.3.9.11 rcvdAnnouncePtr: a pointer to a structure that contains the fields of a received Announce message.

10.3.9.12 rcvdMsg: a Boolean variable that is TRUE if a received Announce message is qualified, and FALSE if it is not qualified.

10.3.9.13 updtInfo: a Boolean variable that is set to TRUE to indicate that the PortAnnounceInformation state machine (see 10.3.11) should copy the newly determined masterPriority and masterStepsRemoved to portPriority and portStepsRemoved, respectively.

10.3.9.14 annLeap61: a global variable in which the leap61 flag (see 10.5.2.2.6) of a received Announce message is saved. The data type for leap61 is Boolean.

10.3.9.15 annLeap59: a global variable in which the leap59 flag (see 10.5.2.2.6) of a received Announce message is saved. The data type for leap59 is Boolean.

10.3.9.16 annCurrentUtcOffsetValid: a global variable in which the currentUtcOffsetValid flag (see 10.5.2.2.6) of a received Announce message is saved. The data type for currentUtcOffsetValid is Boolean.

10.3.9.17 annTimeTraceable: a global variable in which the timeTraceable flag (see 10.5.2.2.6) of a received Announce message is saved. The data type for timeTraceable is Boolean.

10.3.9.18 annFrequencyTraceable: a global variable in which the frequencyTraceable flag (see 10.5.2.2.6) of a received Announce message is saved. The data type for frequencyTraceable is Boolean.

10.3.9.19 annCurrentUtcOffset: a global variable in which the currentUtcOffset field (see 10.5.3.2.1) of a received Announce message is saved. The data type for currentUtcOffset is Integer16.

10.3.9.20 annTimeSource: a global variable in which the timeSource field (see 10.5.3.2.1) of a received Announce message is saved. The data type for timeSource is Enumeration8.

10.3.10 PortAnnounceReceive state machine

10.3.10.1 State machine variables

10.3.10.1.1 rcvdAnnounce: a Boolean variable that notifies the current state machine when Announce message information is received from the MD entity of the same port. This variable is reset by this state machine.

10.3.10.2 State machine functions

10.3.10.2.1 qualifyAnnounce (rcvdAnnouncePtr): qualifies the received Announce message pointed to by rcvdAnnouncePtr as follows:

- a) If the Announce message was sent by the current time-aware system, i.e., if sourcePortIdentity.clockIdentity (see 10.5.2.2.8 and 8.5.2) is equal to thisClock (see 10.2.3.22), the Announce message is not qualified and FALSE is returned;
- b) If the stepsRemoved field is greater than or equal to 255, the Announce message is not qualified and FALSE is returned;
- c) If a path trace TLV is present and one of the elements of the pathSequence array field of the path trace TLV is equal to thisClock (i.e., the clockIdentity of the current time-aware system, see 10.2.3.22), the Announce message is not qualified and FALSE is returned;
- d) Otherwise, the Announce message is qualified and TRUE is returned. If a path trace TLV is present and the portRole of the port is SlavePort, the pathSequence array field of the TLV is copied to the global array pathTrace, and thisClock is appended to pathTrace (i.e., is added to the end of the array).

10.3.10.3 State diagram

The PortAnnounceReceive state machine shall implement the function specified by the state diagram in Figure 10-12, the local variables specified in 10.3.10.1, the functions specified in 10.3.10.2, and the relevant global variables specified in 10.2.3, 10.2.4, 10.3.9, and 11.2.12. The state machine receives Announce information from the MD entity of the same port, determines if the Announce message is qualified, and if so, sets the rcvdMsg variable.

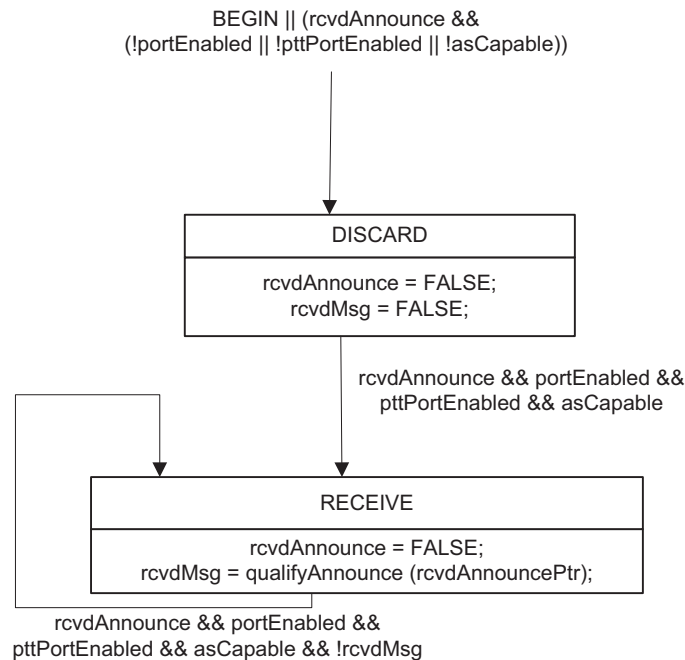

Figure 10-12—PortAnnounceReceive state machine

10.3.11 PortAnnounceInformation state machine

10.3.11.1 State machine variables

10.3.11.1.1 announceReceiptTimeoutTime: a variable used to save the time at which announce receipt timeout occurs. The data type for announceReceiptTimeoutTime is UScaledNs.

10.3.11.1.2 messagePriority: the messagePriorityVector corresponding to the received Announce information. The data type for messagePriority is UInteger224 (see 10.3.4).

10.3.11.1.3 rcvdInfo: an Enumeration2 that holds the value returned by rcvInfo() (see 10.3.11.2.1).

10.3.11.2 State machine functions

10.3.11.2.1 rcvInfo (rcvdAnnouncePtr): decodes the messagePriorityVector (see 10.3.4 and 10.3.5) and stepsRemoved 10.5.3.2.6) field from the Announce information pointed to by rcvdAnnouncePtr (see 10.3.9.11), and then does the following:

- Stores the messagePriorityVector and stepsRemoved field value in msgPriority and msgStepsRemoved, respectively,
- Returns SuperiorMasterInfo if the received message conveys the port role MasterPort, and the messagePriorityVector is superior to the portPriorityVector of the port,
- Returns RepeatedMasterInfo if the received message conveys the port role MasterPort, and the messagePriorityVector is the same as the portPriorityVector of the port,
- Returns InferiorMasterInfo if the received message conveys the port role MasterPort, and the messagePriorityVector is worse than the portPriorityVector of the port,
- Otherwise, returns OtherInfo.

10.3.11.2.2 recordOtherAnnounceInfo(): saves the flags leap61, leap59, currentUtcOffsetValid, timeTraceable, and frequencyTraceable, and the fields currentUtcOffset and timeSource, of the received Announce message for this port. The values are saved in the per-port global variables annLeap61, annLeap59, annCurrentUTCOffsetValid, annTimeTraceable, annFrequencyTraceable, annCurrentUTCOffset, and annTimeSource (see 10.3.9.14 through 10.3.9.20).

10.3.11.3 State diagram

The PortAnnounceInformation state machine shall implement the function specified by the state diagram in Figure 10-13, the local variables specified in 10.3.11.1, the functions specified in 10.3.11.2, and the relevant global variables specified in 10.2.3, 10.2.4, 10.3.8, 10.3.9, and 11.2.12. The state machine receives new qualified Announce information from the PortAnnounceReceive state machine (see 10.3.10) of the same port and determines if the Announce information is better than the current best master information it knows about. The state machine also updates the current best master information when it receives updated port role information from the PortRoleSelection state machine (see 10.3.12), and when announce receipt timeout or, in the case where gmPresent is TRUE, sync receipt timeout occurs.

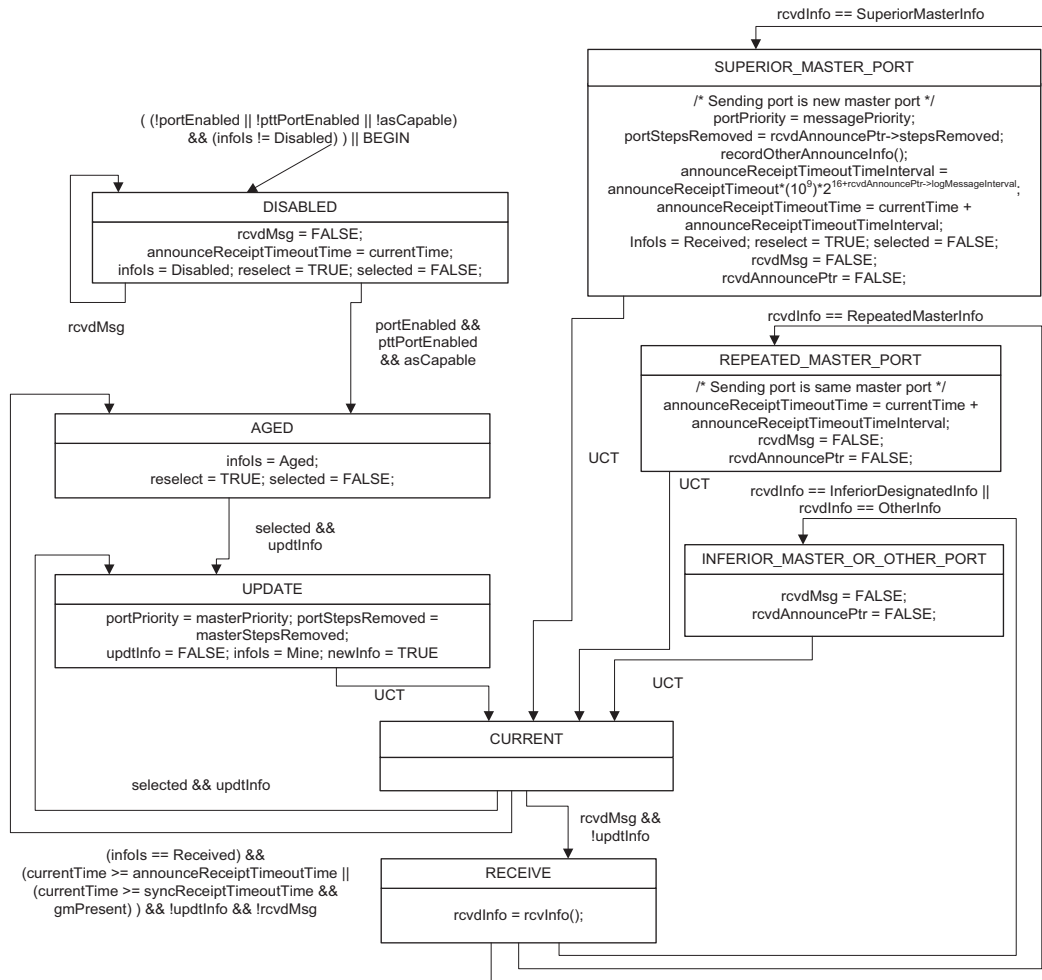

Figure 10-13—PortAnnounceInformation state machine

10.3.12 PortRoleSelection state machine

10.3.12.1 State machine functions

10.3.12.1.1 updtRoleDisabledTree(): sets all the elements of the selectedRole array (see 10.2.3.20) to DisabledPort. Sets lastGmPriority to all ones. Sets the pathTrace array (see 10.3.8.21) to contain the single element thisClock (see 10.2.3.22).

10.3.12.1.2 clearReselectTree(): sets all the elements of the reselect array (see 10.3.8.1) to FALSE.

10.3.12.1.3 setSelectedTree(): sets all the elements of the selected array (see 10.3.8.2) to TRUE.

10.3.12.1.4 updtRolesTree (): performs the following operations (see 10.3.4 and 10.3.5 for details on the priority vectors):

- a) Computes the gmPathPriorityVector for each port that has a portPriorityVector and for which neither announce receipt timeout nor, if gmPresent is TRUE, sync receipt timeout have occurred,
- b) Saves gmPriority (see 10.3.8.19) in lastGmPriority (see 10.3.8.20), computes the gmPriorityVector for the time-aware system and saves it in gmPriority, chosen as the best of the set consisting of the systemPriorityVector (for this time-aware system) and the gmPathPriorityVector for each port for which the clockIdentity of the master port is not equal to thisClock (see 10.2.3.22),
- c) Sets the per-time-aware system global variables leap61, leap59, currentUtcOffsetValid, timeTraceable, frequencyTraceable, currentUtcOffset, and timeSource as follows:
 - 1) If the gmPriorityVector was set to the gmPathPriorityVector of one of the ports, then leap61, leap59, currentUtcOffsetValid, timeTraceable, frequencyTraceable, currentUtcOffset, and timeSource are set to annLeap61, annLeap59, annCurrentUtcOffsetValid, annTimeTraceable, annFrequencyTraceable, annCurrentUtcOffset, and annTimeSource, respectively, for that port.
 - 2) If the gmPriorityVector was set to the systemPriorityVector, then leap61, leap59, currentUtcOffsetValid, timeTraceable, frequencyTraceable, currentUtcOffset, and timeSource are set to sysLeap61, sysLeap59, sysCurrentUtcOffsetValid, sysTimeTraceable, sysFrequencyTraceable, sysCurrentUtcOffset, and sysTimeSource, respectively.
- d) Computes the first three components and the clockIdentity of the fourth component of the masterPriorityVector for each port (i.e., everything except the portNumber of the fourth component)
- e) Computes masterStepsRemoved, which is equal to:
 - 1) messageStepsRemoved (see 10.3.9.7) for the port associated with the gmPriorityVector, incremented by 1, if the gmPriorityVector is not the systemPriorityVector, or
 - 2) 0 if the gmPriorityVector is the systemPriorityVector,
- f) assigns the port role for port j and sets selectedRole[j] equal to this port role, as follows, for j = 1, 2, ..., numberPorts:
 - 3) If the port is disabled (infoIs == Disabled), selectedRole[j] is set to DisabledPort.
 - 4) If announce receipt timeout, or sync receipt timeout with gmPresent set to TRUE, have occurred (infoIs = Aged), updtInfo is set to TRUE and selectedRole[j] is set to MasterPort.
 - 5) If the portPriorityVector was derived from another port on the time-aware system or from the time-aware system itself as the root (infoIs == Mine), selectedRole[j] is set to MasterPort. In addition, updtInfo is set to TRUE if the portPriorityVector differs from the masterPriorityVector or portStepsRemoved differs from masterStepsRemoved.
 - 6) If the portPriorityVector was received in an Announce message and announce receipt timeout, or sync receipt timeout with gmPresent TRUE, have not occurred (infoIs == Received), and the gmPriorityVector is now derived from the portPriorityVector, selectedRole[j] is set to SlavePort and updtInfo is set to FALSE.
 - 7) If the portPriorityVector was received in an Announce message and announce receipt timeout, or sync receipt timeout with gmPresent TRUE, have not occurred (infoIs == Received), the gmPriorityVector is not now derived from the portPriorityVector, the masterPriorityVector is not higher than the portPriorityVector, and the sourcePortIdentity component of the

- portPriorityVector *does not* reflect another port on the time-aware system, selectedRole[j] is set to PassivePort and updInfo is set to FALSE.
- 8) If the portPriorityVector was received in an Announce message and announce receipt timeout, or sync receipt timeout with gmPresent TRUE, have not occurred (infoIs == Received), the gmPriorityVector is not now derived from the portPriorityVector, the masterPriorityVector is not higher than the portPriorityVector, and the sourcePortIdentity component of the portPriorityVector *does* reflect another port on the time-aware system, selectedRole[j] set to PassivePort and updInfo is set to FALSE.
 - 9) If the portPriorityVector was received in an Announce message and announce receipt timeout, or sync receipt timeout with gmPresent TRUE, have not occurred (infoIs == Received), the gmPriorityVector is not now derived from the portPriorityVector, and the masterPriorityVector is better than the portPriorityVector, selectedRole[j] set to MasterPort and updInfo is set to TRUE.
 - g) Updates gmPresent as follows:
 - 10) gmPresent is set to TRUE if the priority1 field of the rootSystemIdentity of the gmPriorityVector is less than 255.
 - 11) gmPresent is set to FALSE if the priority1 field of the rootSystemIdentity of the gmPriorityVector is equal to 255.
 - h) Assigns the port role for port 0, and sets selectedRole[0], as follows:
 - 12) if selectedRole[j] is set to SlavePort for any port with portNumber j, j = 1, 2, ..., numberPorts, selectedRole[0] is set to PassivePort.
 - 13) if selectedRole[j] is *not* set to SlavePort for any port with portNumber j, j = 1, 2, ..., numberPorts, selectedRole[0] is set to SlavePort.
 - i) If the clockIdentity member of the systemIdentity (see 10.3.2) member of gmPriority (see 10.3.8.19) is equal to thisClock (see 10.2.3.22), i.e., if the current time-aware system is the grandmaster, the pathTrace array is set to contain the single element thisClock (see 10.2.3.22).

10.3.12.2 State diagram

The PortRoleSelection state machine shall implement the function specified by the state diagram in Figure 10-14, the functions specified in 10.3.12.1, and the relevant global variables specified in 10.2.3, 10.2.4, 10.3.8, 10.3.9, and 11.2.12. The state machine updates the gmPathPriority vector for each port of the time-aware system, the gmPriorityVector for the time-aware system, and the masterPriorityVector for each port of the time-aware system. The state machine determines the port role for each port and updates gmPresent.

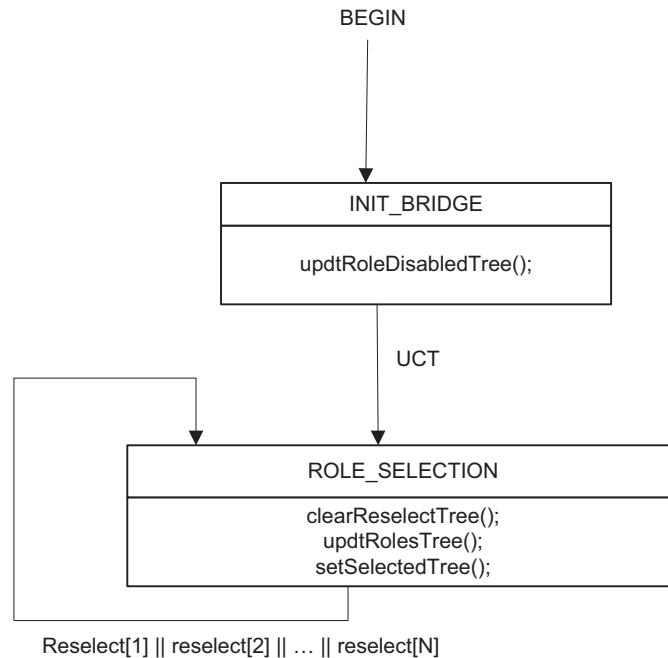

Figure 10-14—PortRoleSelection state machine

10.3.13 PortAnnounceTransmit state machine

10.3.13.1 State machine variables

10.3.13.1.1 announceSendTime: the time, relative to the LocalClock, at which the next transmission of Announce information is to occur. The data type for announceSendTime is UScaledNs.

10.3.13.2 State machine functions

10.3.13.2.1 txAnnounce (): transmits Announce information to the MD entity of this port. The Announce information is set as follows:

- The components of the messagePriorityVector are set to the values of the respective components of the masterPriorityVector of this port.
- The grandmasterIdentity, grandmasterClockQuality, grandmasterPriority1, and grandmasterPriority2 fields of the Announce message are set equal to the corresponding components of the messagePriorityVector.
- The value of the stepsRemoved field of the Announce message is set equal to masterStepsRemoved.
- The Announce message flags leap61, leap59, currentUtcOffsetValid, timeTraceable, and frequencyTraceable, and the Announce message fields currentUtcOffset and timeSource, are set equal to the values of the global variables leap61, leap59, currentUtcOffsetValid, timeTraceable, frequencyTraceable, currentUtcOffset, and timeSource, respectively (see 10.3.8.4 through 10.3.8.10).
- The sequenceId field of the Announce message is set in accordance with 10.4.7.
- A path trace TLV (see 10.5.3.3) is constructed, with its pathSequence field (see 10.5.3.3.4) set equal to the pathTrace array (see 10.3.8.21). If appending the path trace TLV to the Announce message

does not cause the media-dependent layer frame to exceed any respective maximum size, the path trace TLV is appended to the Announce message; otherwise, it is not appended.

10.3.13.3 State diagram

The PortAnnounceTransmit state machine shall implement the function specified by the state diagram in Figure 10-15, the local variables specified in 10.3.13.1, the function specified in 10.3.13.2, and the relevant global variables specified in 10.2.3, 10.2.4, 10.3.9, and 11.2.12. The state machine transmits Announce information to the MD entity when an announce interval has elapsed, port roles have been updated, and portPriority and portStepsRemoved information has been updated with newly determined masterPriority and masterStepsRemoved information.

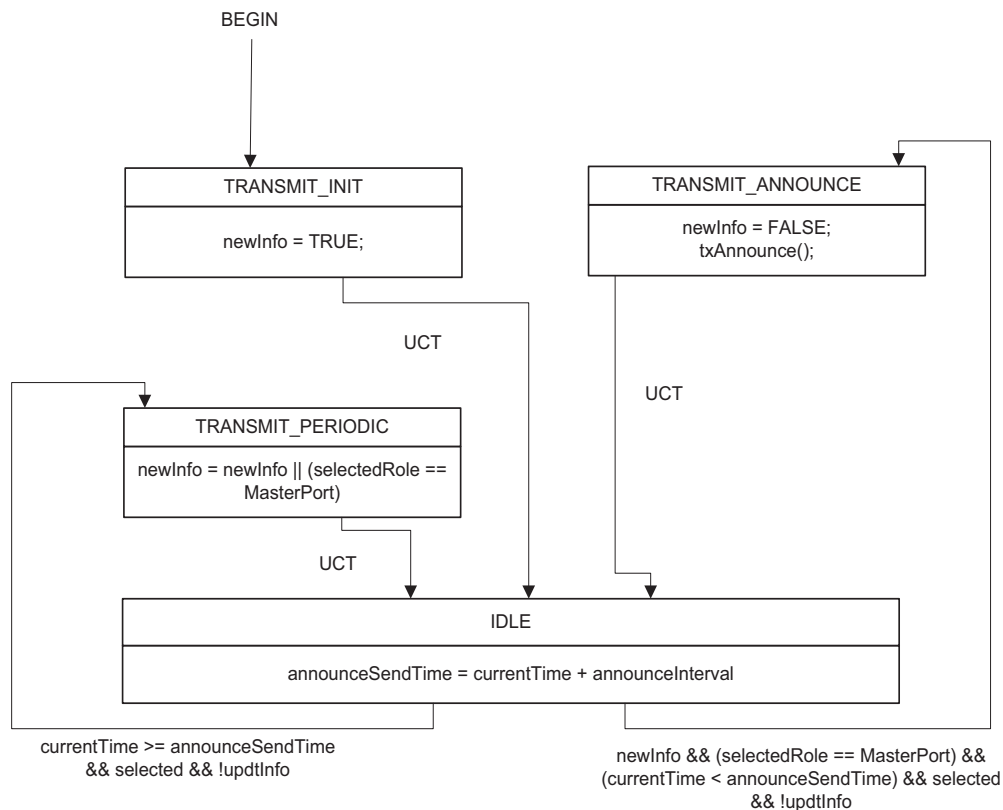

Figure 10-15—PortAnnounceTransmit state machine

10.3.14 AnnounceIntervalSetting state machine

10.3.14.1 State machine variables

The following variables are used in the state diagram of 10.3.14.2:

10.3.14.1.1 rcvdSignalingMsg2: a Boolean variable that notifies the current state machine when a Signaling message that contains a Message Interval Request TLV (see 10.5.4.3) is received. This variable is reset by the current state machine.

10.3.14.1.2 rcvdSignalingPtr: a pointer to a structure whose members contain the values of the fields of the received Signaling message that contains a Message Interval Request TLV (see 10.5.4.3).

10.3.14.2 State diagram

The AnnounceIntervalSetting state machine shall implement the function specified by the state diagram in Figure 10-16, the local variables specified in 10.3.14.1, the messages specified in 10.5, the relevant global variables specified in 10.2.4, and the relevant timing attributes specified in 10.6. This state machine is responsible for setting the global variables that give the duration of the mean interval between successive Announce messages, both at initialization and in response to the receipt of a Signaling message that contains a Message Interval Request TLV (see 10.5.4.3).

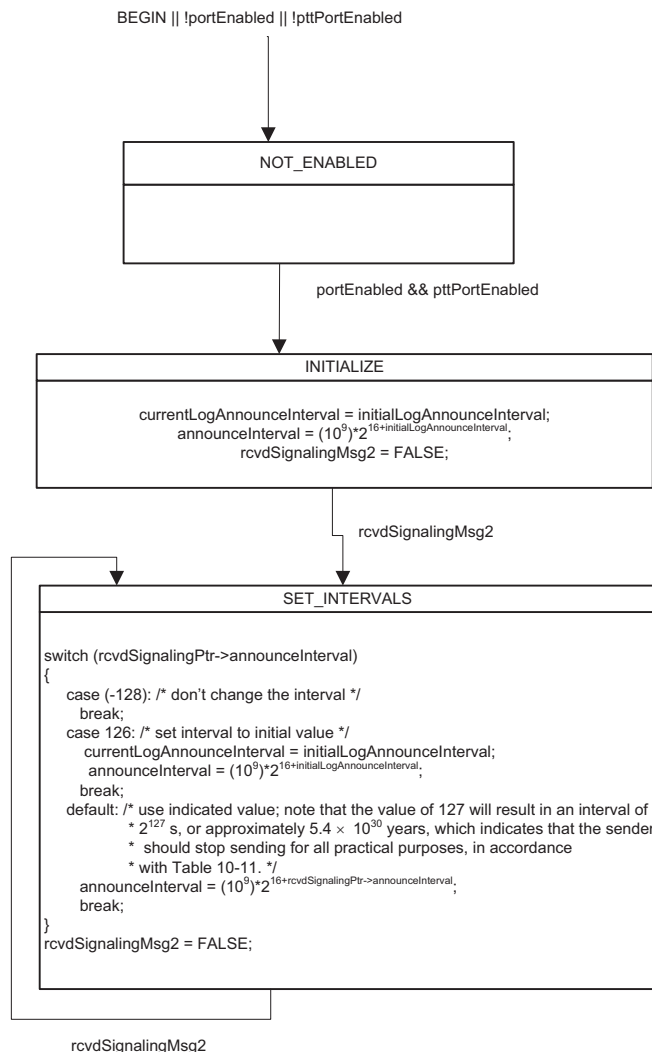

Figure 10-16—AnnounceIntervalSetting state machine

10.4 Message attributes

10.4.1 General

This subclause describes media-independent attributes of the Announce message and the Signaling message that are not described in 8.4.2, and whose descriptions are not generic to all messages used in this standard. This subclause also describes media-independent attributes of all time-synchronization event messages.

10.4.2 Message class

The Announce message is a general message, i.e., it is not timestamped. An Announce message provides status and characterization information of the time-aware system that transmitted the message and the grandmaster. This information is used by the receiving time-aware end station when executing the BMCA.

The Signaling message is a general message, i.e., it is not timestamped. A Signaling message carries information, requests, and/or commands between time-aware systems, via one or more TLVs.

NOTE—In this standard, the Signaling message is used by a port of a time-aware system to request that the port at the other end of the link send time-synchronization event messages, link delay measurement messages, or Announce messages at desired intervals, and to indicate whether the port at the other end of the link should compute neighborRateRatio and/or neighborPropDelay. A single TLV, termed the *message interval request TLV*, is defined to carry this information (see 10.5.4.3). One usage of this functionality is to allow a time-aware system in power-saving mode to remain connected to a gPTP domain via the port on which the Signaling message is sent.

10.4.3 Addresses

The destination address of the Announce and Signaling messages shall be the reserved multicast address given in Table 10-2 unless otherwise specified in a media-dependent clause (see E.2 and 12.2).

Table 10-2—Destination address for Announce and Signaling messages

Destination address
01-80-C2-00-00-0E
NOTE—This address is taken from Table 8-1 of IEEE Std 802.1Q-2005.

NOTE—Frames whose destination address is the address of Table 10-2 are never forwarded, according to IEEE 802.1Q-2005. Use of this address is shared by IEEE 802.1AS and other IEEE 802.1 protocols.

10.4.4 Ethertype

The Ethertype of the Announce and Signaling messages shall be the Ethertype given in Table 10-3.

Table 10-3—Ethertype for Announce and Signaling messages

Ethertype
88F7 ₁₆

NOTE—This Ethertype is used for all PTP messages.

10.4.5 Subtype

The subtype of the Announce and Signaling messages is indicated by the transportSpecific field (see 10.5.2.2.1).

NOTE—The subtype for all PTP messages is indicated by the transportSpecific field.

10.4.6 Source port identity

The Announce message, Signaling message, and all time-synchronization event messages contain a sourcePortIdentity field, see 10.5.2.2.8, that identifies the time-aware end station where the information contained in each message originated.

10.4.7 Sequence number

Each PortSync entity of a time-aware system maintains a separate sequenceId pool for each of the message types Announce and Signaling, respectively, transmitted by the MD entity of the port.

Each Announce and Signaling message contains a sequenceId field, see 10.5.2.2.9, that carries the message sequence number. The sequenceId of an Announce message shall be one greater than the sequenceId of the previous Announce message sent by the transmitting port, subject to the constraints of the rollover of the UInteger16 data type used for the sequenceId field. The sequenceId of a Signaling message shall be one greater than the sequenceId of the previous Signaling message sent by the transmitting port, subject to the constraints of the rollover of the UInteger16 data type used for the sequenceId field.

10.5 Message formats

10.5.1 General

The PTP messages Announce and Signaling each have a header, body, and, if present, a suffix that contains one or more TLVs (see 10.5.2, 10.5.3, 10.5.4, and Clause 14 of IEEE Std 1588-2008). Reserved fields shall be transmitted with all bits of the field 0 and ignored by the receiver, unless otherwise specified. The data type of the field shall be the type indicated in brackets in the title of each subclause.

This subclause defines the path trace TLV, which is carried by the Announce message (see 10.5.3.2.8), and the message interval request TLV, which is carried by the Signaling message (see 10.5.4.3). If a time-aware system cannot parse a TLV, it shall ignore it and attempt to parse the next TLV (see 14.1 of IEEE Std 1588-2008).

NOTE—Any overhead specific to the respective medium is added to each message.

10.5.2 Header

10.5.2.1 General header specifications

The common header for all PTP messages shall be as specified in Table 10-4 and 10.5.2.2 and its subclauses.

10.5.2.2 Header field specifications

10.5.2.2.1 transportSpecific (Nibble)

The value is 0x1.

10.5.2.2.2 messageType (Enumeration4)

The value indicates the type of the message, as defined in Table 10-5.

The most significant bit of the messageType field divides this field in half between event and general messages, i.e., it is 0 for event messages and 1 for general messages.

NOTE—The reserved nibble immediately following messageType is reserved for future expansion of the messageType field.

Table 10-4—PTP message header

Bits								Octets	Offset
8	7	6	5	4	3	2	1		
transportSpecific				messageType				1	0
reserved				versionPTP				1	1
messageLength								2	2
domainNumber								1	4
reserved								1	5
flags								2	6
correctionField								8	8
reserved								4	16
sourcePortIdentity								10	20
sequenceId								2	30
control								1	32
logMessageInterval								1	33

Table 10-5—Values for messageType field

Message type	Message class	Value
Announce	General	0xB
Signaling	General	0xC
NOTE—Values for the messageType field for PTP other messages that are used only for specific media are defined in the respective media-dependent clause(s).		

10.5.2.2.3 versionPTP (UInteger4)

The value is 2.

NOTE—VersionPTP indicates the version number of IEEE 1588 PTP used in the PTP profile contained in this standard.

10.5.2.2.4 messageLength (UInteger16)

The value is the total number of octets that form the PTP message. The counted octets start with and include the first octet of the header and terminate with and include the last octet of the last TLV or, if there are no TLVs, with the last octet of the message as defined in this clause.

NOTE—For example, the Follow_Up message (see 11.4.4) contains a PTP header (34 octets), preciseOriginTimestamp (10 octets), and Follow_Up information TLV (32 octets). The value of the messageLength field is $34+10+32 = 76$.

10.5.2.2.5 domainNumber (UInteger8)

The value is the gPTP domain number specified in 8.1.

10.5.2.2.6 Flags (Octet2)

The value of the bits of the array are defined in Table 10-6. For message types where the bit is not defined in Table 10-6, the value of the bit is set to FALSE.

Table 10-6—Values of flag bits

Octet	Bit	Message Types	Name	Value
1	0	Announce	leap61	The value of the global variable leap61 (see 10.3.8.4)
1	1	Announce	leap59	The value of the global variable leap59 (see 10.3.8.5)
1	2	Announce	currentUtcOffsetValid	The value of the global variable currentUtcOffsetValid (see 10.3.8.6)
1	3	All	ptpTimescale	Reserved as TRUE, ignored on reception
1	4	Announce	timeTraceable	The value of the global variable timeTraceable (see 10.3.8.7)
1	5	Announce	frequencyTraceable	The value of the global variable frequencyTraceable (see 10.3.8.8)

10.5.2.2.7 correctionField (Integer64)

The value is 0.

10.5.2.2.8 sourcePortIdentity (PortIdentity)

The value is the port identity attribute, see 8.5.2, of the port that transmits the PTP message.

10.5.2.2.9 sequenceId (UInteger16)

The sequenceId field is assigned as specified in 10.4.7.

10.5.2.2.10 control (UInteger8)

The value is 0x5.

10.5.2.2.11 logMessageInterval (Integer8)

For an Announce message, the value is the value of currentLogAnnounceInterval, see 10.3.9.4, for the port that transmits the Announce message. For a Signaling message, the value is reserved as 0x7F and ignored on reception.

10.5.3 Announce message

10.5.3.1 General Announce message specifications

The fields of the body of the Announce message shall be as specified in Table 10-7 and 10.5.3.2 and its subclauses.

Table 10-7—Announce message fields

Bits								Octets	Offset
8	7	6	5	4	3	2	1		
header (see 10.5.2)								34	0
reserved								10	34
currentUtcOffset								2	44
reserved								1	46
grandmasterPriority1								1	47
grandmasterClockQuality								4	48
grandmasterPriority2								1	52
grandmasterIdentity								8	53
stepsRemoved								2	61
timeSource								1	63
path trace TLV								4+8N	64

10.5.3.2 Announce message field specifications

10.5.3.2.1 currentUtcOffset (Integer16)

The value is the value of currentUtcOffset (see 10.3.8.9) for the time-aware system that transmits the Announce message.

10.5.3.2.2 grandmasterPriority1 (UInteger8)

The value is the value of the priority1 component of the rootSystemIdentity of the gmPriorityVector (see 10.3.5) of the time-aware system that transmits the Announce message.

10.5.3.2.3 grandmasterClockQuality (ClockQuality)

The value is the clockQuality formed by the clockClass, clockAccuracy, and offsetScaledLogVariance of the rootSystemIdentity of the gmPriorityVector (see 10.3.5) of the time-aware system that transmits the Announce message.

10.5.3.2.4 grandmasterPriority2 (UInteger8)

The value is the value of the priority2 component of the rootSystemIdentity of the gmPriorityVector (see 10.3.5) of the time-aware system that transmits the Announce message.

10.5.3.2.5 grandmasterIdentity (ClockIdentity)

The value is the value of the clockIdentity component of the rootSystemIdentity of the gmPriorityVector (see 10.3.5) of the time-aware system that transmits the Announce message.

10.5.3.2.6 stepsRemoved (UInteger16)

The value is the value of masterStepsRemoved (see 10.3.8.3) for the time-aware system that transmits the Announce message.

10.5.3.2.7 timeSource (Enumeration8)

The value is the value of timeSource (see 10.3.8.10) for the time-aware system that transmits the Announce message.

10.5.3.2.8 Path trace TLV

The Announce message carries the path trace TLV, defined in 10.5.3.3.

10.5.3.3 Path trace TLV definition

10.5.3.3.1 General

The fields of the path TLV shall be as specified in Table 10-8 and in 10.5.4.3.2 through 10.5.4.3.9. This TLV, and its use, are defined in IEEE Std 1588-2008 (see 16.2 and Table 34 of IEEE Std 1588-2008).

Table 10-8—Path trace TLV

Bits								Octets	Offset from start of TLV
8	7	6	5	4	3	2	1		
tlvType								2	0
lengthField								2	2
pathSequence								8N	4

10.5.3.3.2 tlvType (Enumeration16)

The value of the tlvType field is 0x8.

NOTE—This is the value that indicates the TLV is a path trace TLV, as specified in 16.2.7.1 and Table 34 of IEEE Std 1588-2008. The value is specified there as PATH_TRACE, whose value is 0x8.

10.5.3.3.3 lengthField (UInteger16)

The value of the lengthField is 8N.

10.5.3.3.4 pathSequence (ClockIdentity[N])

The value of pathSequence is a ClockIdentity array. The array elements are the clockIdentities of the successive time-aware systems that receive and send an Announce message. The quantity N is the number of time-aware systems, including the grandmaster, that the Announce information has traversed.

NOTE—N is equal to stepsRemoved+1 (see 10.5.3.2.6). The size of the pathSequence array increases by 1 for each time-aware system that the Announce information traverses.

10.5.4 Signaling message

10.5.4.1 General Signaling message specifications

The fields of the body of the Signaling message shall be as specified in Table 10-9 and 10.5.4.2 and its subclauses.

Table 10-9—Signaling message fields

Bits								Octets	Offset
8	7	6	5	4	3	2	1		
header (see 10.5.2)								34	0
targetPortIdentity								10	34
message interval request TLV								16	44

10.5.4.2 Signaling message field specifications

10.5.4.2.1 targetPortIdentity (PortIdentity)

The value is 0xFF.

10.5.4.2.2 Message interval request TLV

The Signaling message carries the message interval request TLV, defined in 10.5.4.3.

10.5.4.3 Message interval request TLV definition

10.5.4.3.1 General

The fields of the message interval request TLV shall be as specified in Table 10-10 and in 10.5.4.3.2 through 10.5.4.3.9. This TLV is a standard organization extension TLV for the Signaling message, as specified in 14.3 of IEEE Std 1588-2008.

10.5.4.3.2 tlvType (Enumeration16)

The value of the tlvType field is 0x3.

NOTE—This is the value that indicates the TLV is a vendor and standard organization extension TLV, as specified in 14.3.2.1 of IEEE Std 1588-2008. The value is specified there as ORGANIZATION_EXTENSION, whose value is 0x3.

Table 10-10—Message interval request TLV

Bits								Octets	Offset from start of TLV
8	7	6	5	4	3	2	1		
tlvType								2	0
lengthField								2	2
organizationId								3	4
organizationSubType								3	7
linkDelayInterval								1	10
timeSyncInterval								1	11
announceInterval								1	12
flags								1	13
reserved								2	14

10.5.4.3.3 lengthField (UInteger16)

The value of the lengthField is 12.

10.5.4.3.4 organizationId (Octet3)

The value of organizationId is 00-80-C2.

10.5.4.3.5 organizationSubType (Enumeration24)

The value of organizationSubType is 2.

10.5.4.3.6 linkDelayInterval (Integer8)

The value is the logarithm to base 2 of the mean time interval, desired by the port that sends this TLV, between successive Pdelay_Req messages sent by the port at the other end of the link. The format and allowed values of linkDelayInterval are the same as the format and allowed values of initialLogPdelayReqInterval, see 11.5.2.2.

The values 127, 126, and –128 are interpreted as defined in Table 10-11.

10.5.4.3.7 timeSyncInterval (Integer8)

The value is the logarithm to base 2 of the mean time interval, desired by the port that sends this TLV, between successive time-synchronization event messages sent by the port at the other end of the link. The format and allowed values of timeSyncInterval are the same as the format and allowed values of initialLogSyncInterval, see 10.6.2.3, 11.5.2.3, 12.6, and 13.9.2.

The values 127, 126, and –128 are interpreted as defined in Table 10-12.

Table 10-11—Interpretation of special values of linkDelayInterval

Value	Instruction to time-aware system that receives this TLV
127	Instructs the port that receives this TLV to stop sending link delay measurement messages.
126	Instructs the port that receives this TLV to set currentLogPdelayReqInterval to the value of initialLogPdelayReqInterval, see 11.5.2.2.
−128	Instructs the port that receives this TLV not to change the mean time interval between successive Pdelay_Req messages.

Table 10-12—Interpretation of special values of timeSyncInterval

Value	Instruction to time-aware system that receives this TLV
127	Instructs the port that receives this TLV to stop sending time-synchronization event messages.
126	Instructs the port that receives this TLV to set currentLogSyncInterval to the value of initialLogSyncInterval, see 10.6.2.3, 11.5.2.3, 12.6, and 13.9.2.
−128	Instructs the port that receives this TLV not to change the mean time interval between successive time-synchronization event messages.

When a signaling message that contains this TLV is sent by a port, the value of syncReceiptTimeoutTimeInterval for that port (see 10.2.4.2) shall be set equal to syncReceiptTimeout (see 10.6.3.1) multiplied by the value of the interval, in seconds, reflected by timeSyncInterval.

10.5.4.3.8 announceInterval (Integer8)

The value is the logarithm to base 2 of the mean time interval, desired by the port that sends this TLV, between successive Announce messages sent by the port at the other end of the link. The format and allowed values of announceInterval are the same as the format and allowed values of initialLogAnnounceInterval, see 10.6.2.2.

The values −128, +126, and +127 are interpreted as defined in Table 10-13.

When a signaling message that contains this TLV is sent by a port, the value of announceReceiptTimeoutTimeInterval for that port (see 10.3.9.1) shall be set equal to announceReceiptTimeout (see 10.6.3.2) multiplied by the value of the interval, in seconds, reflected by announceInterval.

Table 10-13—Interpretation of special values of announceInterval

Value	Instruction to time-aware system that receives this TLV
127	Instructs the port that receives this TLV to stop sending Announce messages.
126	Instructs the port that receives this TLV to set currentLogAnnounceInterval to the value of initialLogAnnounceInterval, see 10.6.2.2.
-128	Instructs the port that receives this TLV not to change the mean time interval between successive Announce messages.

10.5.4.3.9 flags (Octet)

Bits 1 and 2 of the octet are defined in Table 10-14 and take on the values TRUE and FALSE.

Table 10-14—Definitions of bits of flags field of message interval request TLV

Bit	Name
1	computeNeighborRateRatio
2	computeNeighborPropDelay

Bits not defined in Table 10-14 are set to FALSE and ignored on receipt.

NOTE—For full-duplex, point-to-point links (see Clause 11), it is expected that the port sending this TLV will set one or both of these bits to FALSE if this port will not provide valid timing information in its subsequent responses (Pdelay_Resp and Pdelay_Resp_Follow_Up) to Pdelay_Req messages.

10.6 Protocol timing characterization**10.6.1 General**

This subclause specifies timing and timeout attributes for the media-independent sublayer state machines.

10.6.2 Message transmission intervals**10.6.2.1 General interval specification**

The mean time interval between the sending of successive Announce messages, referred to as the *announce interval*, shall be as specified in 10.6.2.2.

The mean time interval between the sending of successive time-synchronization event messages for full-duplex point-to-point, IEEE 802.11, and CSN links, and successive general messages containing time-synchronization information for IEEE 802.3 EPON links, is referred to as the sync interval. The sync interval shall be as specified in 10.6.2.3.

10.6.2.2 Announce message transmission interval

The logarithm to the base 2 of the announce interval (in seconds) is carried in the `logMessageInterval` field of the Announce message.

The `initialLogAnnounceInterval` specifies the announce interval when the port is initialized and the value the announce interval is set to when a message interval request TLV is received with the `announceInterval` field set to 126 (see the `AnnounceIntervalSetting` state machine, 10.3.14). The `currentLogAnnounceInterval` specifies the current value of the announce interval. The default value of `initialLogAnnounceInterval` is 0. Every port supports the value 127; the port does not send Announce messages when `currentLogAnnounceInterval` has this value (see 10.3.14). A port may support other values, except for the reserved values -128 through -125 , inclusive, and 124 through 126, inclusive. A port ignores requests (see 10.3.14) for unsupported values. The `initialLogAnnounceInterval` and `currentLogAnnounceInterval` are per-port attributes.

NOTE 1—The value of `initialLogAnnounceInterval` is the value of the mean time interval between successive Announce messages when the port is initialized. The value of the mean time interval between successive Announce messages may be changed, e.g., if the port receives a Signaling message that carries a message interval request TLV (see 10.5.4.3), and the current value is stored in `currentLogAnnounceInterval`. The value of the mean time interval between successive Announce messages can be reset to the initial value, e.g., by a message interval request TLV for which the value of the field `announceInterval` is 126, see 10.5.4.3.8.

NOTE 2—A port that requests (using a Signaling message that contains a message interval request TLV, see 10.5.4 and 10.3.14) that the port at the other end of the attached link set its `currentLogAnnounceInterval` to a specific value can determine if the request was honored by examining the `logMessageInterval` field of subsequent received Announce messages.

10.6.2.3 time-synchronization event message transmission interval

The logarithm to the base 2 of the sync interval (in seconds) is carried in the `logMessageInterval` field of the time-synchronization messages.

The `initialLogSyncInterval` specifies the sync interval when the port is initialized and the value the sync interval is set to when a message interval request TLV is received with the `timeSyncInterval` field set to 126 (see the `LinkDelaySyncIntervalSetting` state machine, 11.2.17). The default value is media-dependent; the value is specified in the respective media-dependent clauses. The `initialLogSyncInterval` is a per-port attribute.

The `currentLogSyncInterval` specifies the current value of the sync interval, and is a per-port attribute.

NOTE—The value of `initialLogSyncInterval` is the value of the sync interval when the port is initialized. The value of the sync interval may be changed, e.g., if the port receives a Signaling message that carries a message interval request TLV (see 10.5.4.3), and the current value is stored in `currentLogSyncInterval`. The value of the sync interval can be reset to the initial value, e.g., by a message interval request TLV for which the value of the field `timeSyncInterval` is 126, see 10.5.4.3.7.

10.6.2.4 Interval for providing synchronization information by ClockMaster entity

The `clockMasterLogSyncInterval` specifies the mean time interval between successive instants at which the ClockMaster entity provides time-synchronization information to the SiteSync entity. The value is less than

or equal to the smallest `currentLogSyncInterval` (see 10.6.2.3) value for all the ports of the time-aware system. The `clockMasterLogSyncInterval` is an internal, per-time-aware system variable.

10.6.3 Timeouts

10.6.3.1 `syncReceiptTimeout`

The value of this attribute tells a slave port the number of sync intervals to wait without receiving synchronization information, before assuming that the master is no longer transmitting synchronization information, and that the BMC algorithm needs to be run, if appropriate. The condition of the slave port not receiving synchronization information for `syncReceiptTimeout` sync intervals is referred to as *sync receipt timeout*.

The default value shall be 3. The `syncReceiptTimeout` is a per-port attribute.

10.6.3.2 `announceReceiptTimeout`

The value of this attribute tells a slave port the number of announce intervals to wait without receiving an Announce message, before assuming that the master is no longer transmitting Announce messages, and that the BMC algorithm needs to be run, if appropriate. The condition of the slave port not receiving an Announce message for `announceReceiptTimeout` announce intervals is referred to as *announce receipt timeout*.

The default value shall be 3. The `announceReceiptTimeout` is a per-port attribute.

11. Media-dependent layer specification for full-duplex, point-to-point links

11.1 Overview

11.1.1 General

A port attached to a full-duplex, point-to-point link uses the PTP peer delay protocol to measure propagation delay on the link. An overview of the propagation delay measurement is given in 11.1.2. Synchronization information is transported using the PTP messages Sync and Follow_Up. An overview of the transport of synchronization information is given in 11.1.3. An overview of the MD entity model for a full-duplex, point-to-point medium is given in 11.1.4.

11.1.2 Propagation delay measurement

The measurement of propagation delay on a full-duplex, point-to-point link using the peer delay mechanism is illustrated in Figure 11-1. The mechanism is the same as the peer delay mechanism described in IEEE Std 1588-2008, specialized to a two-step clock¹⁵ and sending the requestReceiptTimestamp and the responseOriginTimestamp separately [see 11.4.3 of IEEE Std 1588-2008, item (c)(8)]. The measurement is made by each port at the end of every full-duplex, point-to-point link. Thus, both ports sharing a link will independently make the measurement, and both ports will know the propagation delay as a result. This allows the time-synchronization information described in 11.1.3 to be transported irrespective of the direction taken by a Sync message. The propagation delay measurement is made on ports otherwise blocked by non-PTP algorithms (e.g., Rapid Spanning Tree Protocol) used to eliminate cyclic topologies. This enables either no loss of synchronization or faster resynchronization, after a reconfiguration, because propagation delays are already known and do not have to be initially measured when the reconfiguration occurs.

In Figure 11-1, the propagation delay measurement is initiated by a time-aware system at one end of a link; this time-aware system is referred to as the *peer delay initiator*. For purposes of the measurement, the other time-aware system is the *peer delay responder*. A similar measurement occurs in the opposite direction, with the initiator and responder interchanged and the directions of the messages in Figure 11-1 reversed.

¹⁵See 3.1.47 of IEEE Std 1588-2008 for the definition of a *two-step clock*.

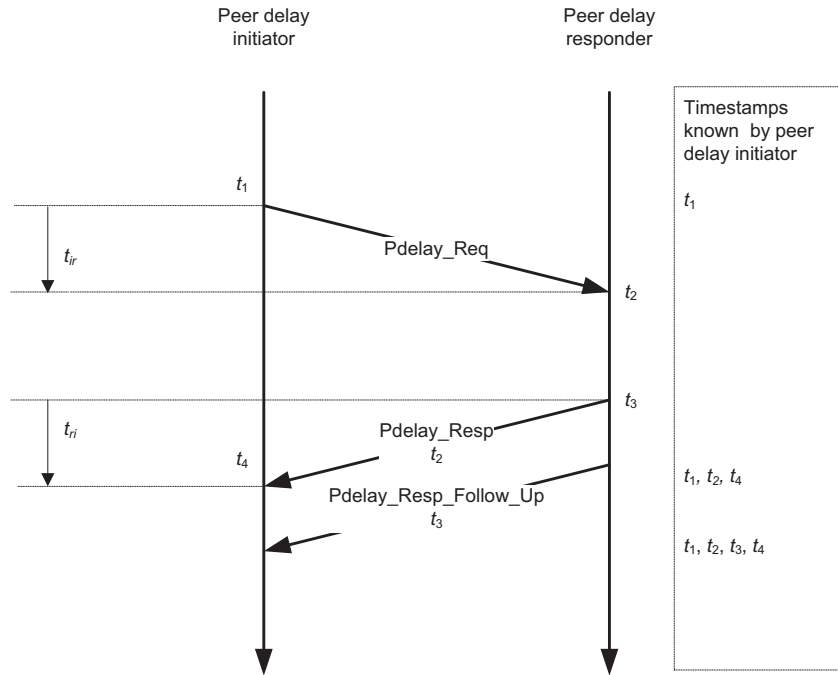

Figure 11-1—Propagation delay measurement using peer delay mechanism

The propagation delay measurement starts with the initiator issuing a `Pdelay_Req` message and generating a timestamp, t_1 . The responder receives this message and timestamps it with time t_2 . The responder returns a `Pdelay_Resp` message and timestamps it with time t_3 . The responder returns the time t_2 in the `Pdelay_Resp` message, and the time t_3 in a `Pdelay_Resp_Follow_Up` message. The initiator generates a timestamp, t_4 , upon receiving the `Pdelay_Resp` message. The initiator then uses these four timestamps to compute the mean propagation delay as shown in Equation (11-1):

$$\begin{aligned}
 t_{ir} &= t_2 - t_1 \\
 t_{ri} &= t_4 - t_3 \\
 D &= \frac{t_{ir} + t_{ri}}{2} = \frac{(t_2 - t_1) - (t_3 - t_2)}{2}
 \end{aligned}
 \tag{11-1}$$

where D is the measured mean propagation delay and the other quantities are defined in Figure 11-1.

Note that it is the mean propagation delay that is measured here. Any link asymmetry is modeled as described in 8.3. Any asymmetry that is not corrected for introduces an error in the transported synchronized time value.

The accuracy of the mean propagation delay measurement depends on how accurately the times t_1 , t_2 , t_3 , and t_4 are measured. In addition, Equation (11-1) assumes that the initiator and responder timestamps are taken relative to clocks that have the same frequency. In practice, t_1 and t_4 are measured relative to the LocalClock entity of the initiator time-aware system, and t_2 and t_3 are measured relative to the LocalClock entity of the responder time-aware system. If the propagation delay measurement is desired relative to the responder time

base, the term $(t_4 - t_1)$ in Equation (11-1) must be multiplied by the rate ratio of the responder relative to the initiator, otherwise there will be an error equal to $0.5y(t_4 - t_1)$, where y is the frequency offset of the responder relative to the initiator. Likewise, if the propagation delay measurement is desired relative to the initiator time base, the term $(t_3 - t_2)$ in Equation (11-1) must be multiplied by the rate ratio of the initiator relative to the responder, otherwise there will be an error equal to $0.5y(t_3 - t_2)$, where y is the frequency offset of the initiator relative to the responder. Finally, if the propagation delay measurement is desired relative to the grandmaster time base, each term must be multiplied by the rate ratio of the grandmaster relative to the time base that term is expressed in.

There can also be an error in measured propagation delay due to time measurement granularity (see B.1.2). For example, if the time measurement granularity is 40 ns (as specified in B.1.2), the timestamps t_1 , t_2 , t_3 , and/or t_4 can undergo 40 ns step changes. When this occurs, the measured propagation delay, D , will change by 20 ns (or by a multiple of 20 ns if more than one of the timestamps has undergone a 40 ns step change). The actual propagation delay has not changed by 20 ns; the effect is due to time measurement granularity. The effect can be reduced, and the accuracy improved, by averaging successive measured propagation delay values. For example, an exponential averaging filter can be used, i.e., as shown in Equation (11-2):

$$D_{avg,k} = aD_{avg,k-1} + (1 - a)D_{k-1} \tag{11-2}$$

where D_k is the k^{th} propagation delay measurement, $D_{avg,k}$ is the k^{th} computed average propagation delay, and k is an index for the propagation delay measurements (i.e., peer delay message exchange). The quantity a is the exponential weighting factor; it can be set so that the weight of a past propagation delay measurement is $1/e$ after M measurements, i.e., as shown in Equation (11-3):

$$a = e^{-\frac{1}{M}} \tag{11-3}$$

The above averager must be initialized. One method is to use a simple average (i.e., the sum of the sample values divided by the number of samples) of the measurements made up to the current measurement until a window of M measurements has been accumulated. In this case, Equation (11-2) is used only for $k > M$. For $k \leq M$, the averaged propagation delay is given by Equation (11-4):

$$D_{avg,k} = \frac{(k - 1)D_{avg,k-1} + D_{k-1}}{k} \tag{11-4}$$

The rate ratio of the responder relative to the initiator is the quantity `neighborRateRatio` (see 10.2.4.6). It is computed by the function `computePdelayRateRatio()` (see 11.2.15.2.3) of the `MDPdelayReq` state machine (see 11.2.15) using successive values of t_3 and t_4 . As indicated in the description of `computePdelayRateRatio()`, any scheme that uses this information is acceptable as long as the performance requirements of B.2.4 are met. One example scheme is given in NOTE 1 of 11.2.15.2.3.

11.1.3 Transport of time-synchronization information

The transport of time-synchronization information by a time-aware system, using `Sync` and `Follow_Up` messages, is illustrated in Figure 11-2. The mechanism is mathematically equivalent to the mechanism described in IEEE Std 1588-2008 for a two-step,¹⁵ peer-to-peer transparent clock that is syntonized (see 11.4.5.1, 11.5.1, and 11.5.2.2 of IEEE Std 1588-2008). However, as will be seen shortly, the processes of transporting synchronization by a two-step, peer-to-peer transparent clock that is syntonized and by a two-step boundary clock are mathematically and functionally equivalent.¹⁶ The main functional difference between the two types of clocks is that the boundary clock participates in best master selection and invokes

¹⁶The same mathematical and functional equivalence exists for one-step boundary and syntonized peer-to-peer transparent clocks. One-step clocks are not discussed here because time-aware systems described in this standard are two-step devices from the standpoint of IEEE Std 1588-2008.

the BMCA, while the peer-to-peer transparent clock does not participate in best master selection and does not invoke the BMCA (and implementations of the two types of clocks can be different).

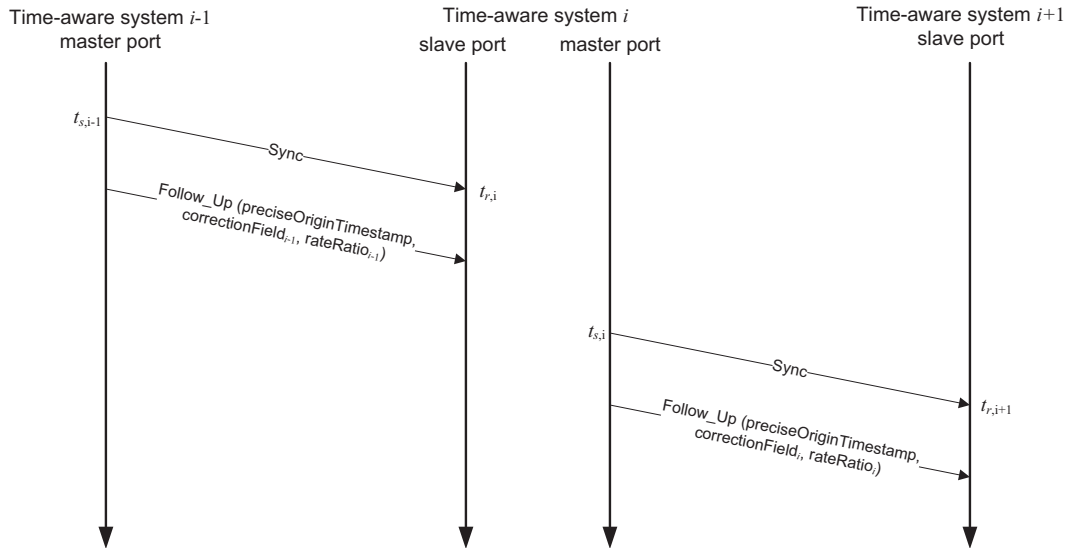

Figure 11-2—Transport of time-synchronization information

Figure 11-2 shows three adjacent time-aware systems, indexed $i-1$, i , and $i+1$. Synchronization is transported from time-aware system $i-1$ to time-aware system i , and then to time-aware system $i+1$. Time-aware system $i-1$ send a Sync message to time-aware system i at time $t_{s,i-1}$, relative to the LocalClock entity of time-aware system $i-1$. At a later time, time-aware system $i-1$ sends an associated Follow_Up message to time-aware system i , which contains a preciseOriginTimestamp, correctionField $_{i-1}$, and rateRatio $_{i-1}$. The preciseOriginTimestamp contains the time of the grandmaster when it originally sent this synchronization information. It is not indexed here because it normally does not change as the Sync and Follow_Up messages traverse the network. The quantity correctionField $_{i-1}$ contains the difference between the synchronized time when the Sync message is sent (i.e., the synchronized time that corresponds to the local time $t_{s,i-1}$) and the preciseOriginTimestamp. The sum of preciseOriginTimestamp and correctionField $_{i-1}$ gives the synchronized time that corresponds to $t_{s,i-1}$. The quantity rateRatio $_{i-1}$ is the ratio of the grandmaster frequency to the frequency of the LocalClock entity of time-aware system $i-1$.

Time-aware system i receives the Sync message from time-aware system $i-1$ at time $t_{r,i}$, relative to its LocalClock entity. It timestamps the receipt of the Sync message, and the timestamp value is $t_{r,i}$. It receives the associated Follow_Up message some time later.

Time-aware system i will eventually send a new Sync message at time $t_{s,i}$, relative to its LocalClock entity. It will have to compute correctionField $_i$, i.e., the difference between the synchronized time that corresponds to $t_{s,i}$ and the preciseOriginTimestamp. To do this, it must compute the value of the time interval between $t_{s,i-1}$ and $t_{s,i}$, expressed in the grandmaster time base. This interval is equal to the sum of the following quantities:

- The propagation delay on the link between time-aware systems $i-1$ and i , expressed in the grandmaster time base, and
- The difference between $t_{s,i}$ and $t_{r,i}$ (i.e., the residence time), expressed in the grandmaster time base.

The mean propagation delay on the link between time-aware systems $i-1$ and i , relative to the LocalClock entity of time-aware system $i-1$, is equal to neighborPropDelay (see 10.2.4.7). This must be divided by

rateRatio_{*i*-1} to express it in the grandmaster time base. The total propagation delay is equal to the mean propagation delay plus the quantity delayAsymmetry (see 8.3 and 10.2.4.8); delayAsymmetry is already expressed in the grandmaster time base. The residence time, $t_{s,i} - t_{r,i}$, must be multiplied by rateRatio_{*i*} to express it in the grandmaster time base.

The preceding computation is organized slightly differently in the state machines of 11.2.13 and 11.2.14. Rather than explicitly expressing the link propagation delay in the grandmaster time base, the local time at time-aware system *i* that corresponds to $t_{s,i-1}$ is computed; this is the upstreamTxTime member of the MDSTSyncReceive structure (see 10.2.2.2.6; recall that $t_{s,i-1}$ is relative to the LocalClock entity of time-aware system *i*-1). upstreamTxTime is equal to the quantity $t_{r,i}$ minus the link propagation delay expressed relative to the LocalClock entity of time-aware system *i*. The link propagation delay expressed relative to the LocalClock entity of time-aware system *i* is equal to the sum of the following:

- c) The quantity neighborPropDelay (see 10.2.4.7) divided by neighborRateRatio (see 10.2.4.6), and
- d) The quantity delayAsymmetry (see 10.2.4.8) divided by rateRatio_{*i*}.

The division of delayAsymmetry by rateRatio_{*i*} is performed after rateRatio_{*i*} has been updated, as described shortly. The computation of upstreamTxTime is done by the MDSTSyncReceiveSM state machine in the function setMDSTSyncReceive() (see 11.2.13.2.1). When time-aware system *i* sends a Sync message to time-aware system *i*+1, it computes the sum of the link propagation delay and residence time, expressed in the grandmaster time base, as:

- e) The quantity $(t_{s,i} - \text{upstreamTxTime})(\text{rateRatio}_i)$.

As in item d) above, this computation is performed after rateRatio_{*i*} has been updated, as described shortly. The quantity of item e) is added to correctionField_{*i*-1} to obtain correctionField_{*i*}. The computation of item e) and correctionField_{*i*} is done by the MDSTSyncSendSM state machine in the function setFollowUp() (see 11.2.14.2.3). The quantity correctionField_{*i*} is inserted in the Follow_Up message sent by time-aware system *i*.

Note that the difference between mean propagation delay relative to the grandmaster time base and relative to the time bases of the time-aware system at the other end of the attached link or of the current time-aware system is usually negligible. To see this, note that the former can be obtained from the latter by multiplying the latter by the ratio of the grandmaster frequency to the frequency of the LocalClock entity of the time-aware system at the other end of the link attached to this port. This ratio differs from 1 by 200 ppm or less. For example, for a worst-case frequency offset of the LocalClock entity of the time-aware system at the other end of the link, relative to the grandmaster, of 200 ppm, and a measured propagation time of 100 ns, the difference in *D* relative to the two time bases is 20 ps. The corresponding difference for link delay asymmetry in this example is also negligible because the magnitude of the link delay asymmetry is of the same order of magnitude as the mean propagation time, or less. However, the difference is usually not negligible for residence time, because residence time can be much larger (see B.2.2).

It was previously indicated that the processes of transporting synchronization by a two-step, peer-to-peer transparent clock that is syntonized and by a two-step boundary clock are mathematically and functionally equivalent. This is because the computations described above compute the synchronized time when the Sync message is sent by the time-aware system. The same computations are done if time-aware system *i* sends a Sync message without having received a new Sync message, i.e., if Sync receipt timeout occurs (see 10.6.3.1). In this case, time-aware system *i* uses the most recently received time-synchronization information from time-aware system *i*-1, which would be prior to time-aware system *i* having sent its most recent Sync message. The synchronized time corresponding to the sending of a Sync message is equal to the sum of the preciseOriginTimestamp and correctionField. Normally a boundary clock places this entire value, except for any sub-nanosecond portion, in the preciseOriginTimestamp, while a transparent clock retains the preciseOriginTimestamp and updates the correction field. However, the sum of the two fields is equal to the synchronized time when the Sync message is sent in both cases.

The ratio of the grandmaster frequency to the frequency of the LocalClock entity at time-aware system i , rateRatio_i , is equal to the same quantity at time-aware system $i-1$, rateRatio_{i-1} , multiplied by the ratio of the frequency of the LocalClock entity at time-aware system $i-1$ to the frequency of the LocalClock entity at time-aware system i , neighborRateRatio (see 10.2.4.6). If neighborRateRatio is sufficiently small, this is approximately equal to the sum of rateRatio_{i-1} and the quantity $\text{neighborRateRatio}-1$, which is the frequency offset of time-aware system $i-1$ relative to time-aware system i . This computation is done by the PortSyncSyncReceive state machine (see 10.2.7).

11.1.4 Model of operation

A time-aware system contains one MD entity per port. This entity contains functions generic to all media, which are described in Clause 10, and functions specific to the respective medium for the link. Functions specific to full-duplex, point-to-point links are described in the current clause.

NOTE—IEEE 802.3 full-duplex, point-to-point links are in the category of links specified in this clause.

The model for a time-aware system with full-duplex, point-to-point links is shown in Figure 11-3. It assumes the presence of one full-duplex, point-to-point MD entity per port. The media-independent entities shown in Figure 11-3 are described in 10.1.1.

A general, media-independent description of the generation of timestamps is given in 8.4.3. A more specific description for PTP event messages is given in 11.3.2.1. A PTP event message is timestamped relative to the LocalClock entity when the message timestamp point (see 3.11) crosses the timestamp measurement plane (see 3.25). The timestamp is corrected for any ingressLatency or egressLatency (see 8.4.3) to produce a timestamp relative to the reference plane (see 3.16). The corrected timestamp value is provided to the MD entity.

The MD entity behavior and detailed state machines specific to full-duplex, point-to-point links are described in 11.2. The behavior of the MD entity that is generic to all media is described in Clause 10.

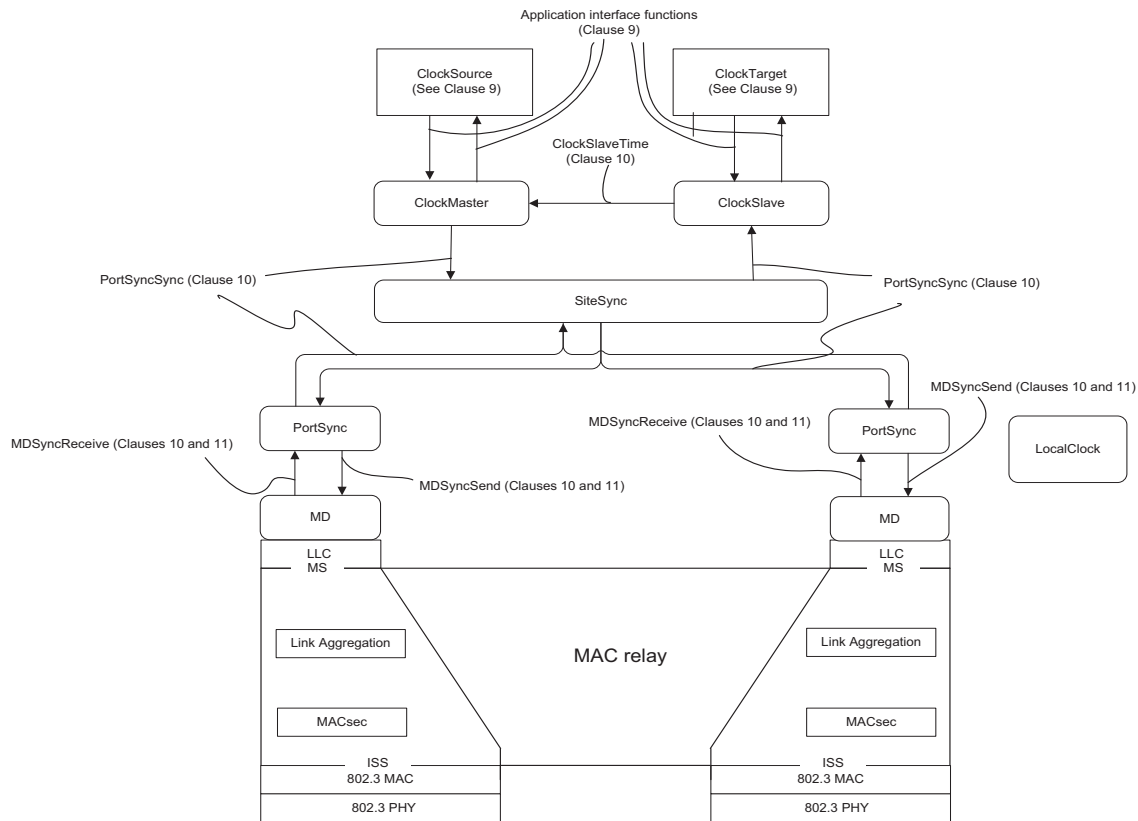

Figure 11-3—Model for time-aware system with full-duplex, point-to-point links

11.2 State machines for MD entity specific to full-duplex, point-to-point links

11.2.1 General

This subclause describes the media-dependent state machines for an MD entity, for the case of full-duplex, point-to-point links. The state machines are all per port, because an instance of each is associated with an MD entity. The state machines are as follows:

- MDSyncReceiveSM (shown in Figure 10-2, and in more detail in Figure 11-4): receives Sync and Follow_Up messages, and sends the time-synchronization information carried in these messages to the PortSync entity of the same port.
- MDSyncSendSM (shown in Figure 10-2, and in more detail in Figure 11-4): receives an MDSyncSend structure from the PortSync entity of the same port, transmits a Sync message, uses the <syncEventEgressTimestamp>, corrected for egressLatency, and information contained in the MDSyncSend structure to compute information needed for the corresponding Follow_Up message, and transmits the Follow_Up message.
- MDPdelayReq (shown in Figure 11-5): transmits a Pdelay_Req message, receives Pdelay_Resp and Pdelay_Resp_Follow_Up messages corresponding to the transmitted Pdelay_Req message, uses the information contained in successive Pdelay_Resp and Pdelay_Resp_Follow_Up messages to compute the ratio of the frequency of the LocalClock entity in the time-aware system at the other end of the attached link to the frequency of the LocalClock entity in this time-aware system, and

- uses the information obtained from the message exchange and the computed frequency ratio to compute propagation delay on the attached link.
- d) MDPdelayResp (shown in Figure 11-5): receives a Pdelay_Req message from the MD entity at the other end of the attached link, and responds with Pdelay_Resp and Pdelay_Resp_Follow_Up messages.
 - e) LinkDelaySyncIntervalSetting state machine (not shown): receives a Signaling message that contains a Message Interval Request TLV (see 10.5.4.3), and sets the global variables that give the duration of the mean intervals between successive Sync and successive Pdelay_Req messages.

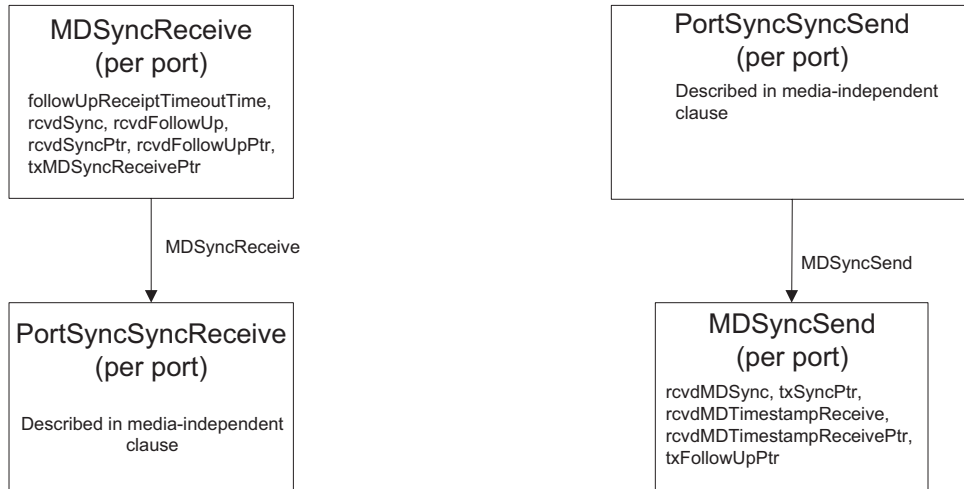

Figure 11-4—Detail of MD entity time-synchronization state machines for full-duplex, point-to-point links

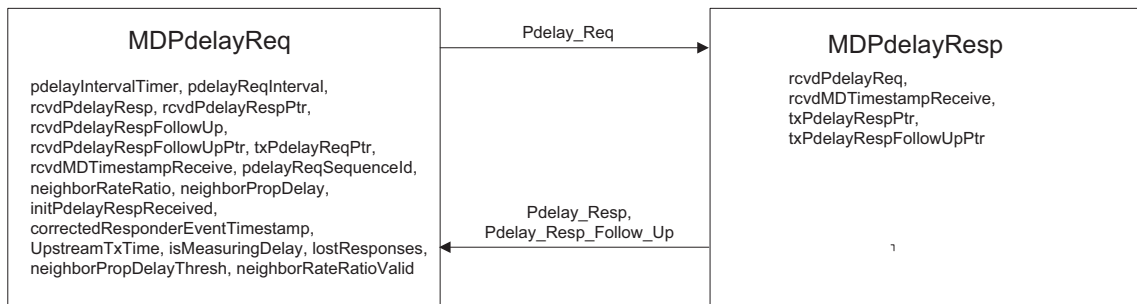

Figure 11-5—Peer delay mechanism state machines—overview and interrelationships

Figure 10-2, Figure 11-4, and Figure 11-5 are not themselves state machines, but illustrate the machines, their interrelationships, the principle variables and messages used to communicate between them, their local variables, and performance parameters. The figures do not show the service interface primitives between the media-dependent layer and the LLC. Figure 11-5 is analogous to Figure 10-2; while Figure 10-2 applies to the general time-synchronization protocol, Figure 11-5 is limited to the peer delay mechanism for measurement of propagation delay in full-duplex, point-to-point links. Figure 11-4 shows greater detail of the MDSyncReceiveSM and MDSyncSendSM state machines than Figure 10-2, for the case of full-duplex, point-to-point links.

The state machines described in 11.2 and its subclauses use some of the global per time-aware system variables defined in 10.2.3, the global per-port variables defined in 10.2.4, and the functions defined in 10.2.5.

11.2.2 Determination of asCapable

The per-port global variable asCapable (see 10.2.4.1) indicates whether or not the IEEE 802.1AS protocol is operating on the link attached to this port, and can provide the time-synchronization performance described in B.3. asCapable is used by the PortSync entity, which is media-independent; however, the determination of asCapable is media-dependent.

For a port attached to a full-duplex, point-to-point link, asCapable shall be set to TRUE if and only if it is determined, via the peer delay mechanism, that the following conditions hold for the port:

- a) The port is exchanging peer delay messages with its neighbor,
- b) The measured delay does not exceed neighborPropDelayThresh,
- c) The port does not receive multiple Pdelay_Resp or Pdelay_Resp_Follow_Up messages in response to a single Pdelay_Req message, and
- d) The port does not receive a response from itself or another port of the same time-aware system.

asCapable is set in the MDPdelayReq state machine (see 11.2.15 and Figure 11-8).

11.2.3 Use of MAC Control PAUSE operation

A time-aware system shall not use the MAC Control PAUSE operation.

11.2.4 Use of priority-based flow control

A time-aware system that implements priority-based flow control shall neither transmit nor honor upon receipt priority-based flow control messages that act on the IEEE 802.1AS message priority code point (see 8.4.4).

11.2.5 Use of link aggregation

The use of link aggregation is not specified. If link aggregation is used, Sync and Pdelay_Resp messages must be part of the same conversation. In addition, if link aggregation is used and the Sync and Pdelay_Resp messages use a different physical link from that used by Pdelay_Req messages in the opposite direction, there can be errors in measured propagation time, i.e., in neighborPropDelay, and measured time offset between the two time-aware systems. The absolute value of the error in neighborPropDelay and measured time offset is equal to the absolute value of one-half the difference between the actual propagation times in the two directions, i.e., the absolute value of the quantity delayAsymmetry (see 8.3 and 10.2.4.8), for the physical links actually used in the two directions.

11.2.6 Service interface primitives and data structures communicated between state machines

The following subclauses describe the service primitives and data structures communicated between the time-synchronization state machines of the MD entity. First the service primitives are described, followed by the data structures.

11.2.7 DL-UNITDATA.request

This service primitive is used by an MD entity to request to the associated LLC the transmission of a Sync, Follow_Up, Pdelay_Req, Pdelay_Resp, or Pdelay_Resp_Follow_Up message. The primitive is described in 2.2.1.1.1 of ISO/IEC 8802-2 [B9].

11.2.8 DL-UNITDATA.indication

This service primitive is used by the LLC to indicate to the associated MD entity the receipt of a Sync, Follow_Up, Pdelay_Req, Pdelay_Resp, or Pdelay_Resp_Follow_Up message. The primitive is described in 2.2.1.1.1 of ISO/IEC 8802-2 [B9].

11.2.9 MDTimestampReceive

11.2.9.1 General

This structure provides the timestamp, relative to the timestamp measurement plane, of the event message that was just sent or just received. The structure is received by the MD entity of the port. The MD entity corrects this timestamp for any ingressLatency or egressLatency (see 8.4.3) before using it and/or passing it to higher layer entities.

The structure is:

```
MDTimestampReceive{  
    timestamp  
}
```

The member of the structure is defined in the following subclause.

11.2.9.2 timestamp (UScaledNs)

The timestamp is the value of the timestamp of the event message (i.e., Sync, Pdelay_Req, Pdelay_Resp) that was just transmitted or received. This timestamp is taken relative to the timestamp measurement plane.

11.2.10 MDSyncReceive

This structure is specified in 10.2.2.2.

11.2.11 MDSyncSend

This structure is specified in 10.2.2.1.

11.2.12 MD entity global variables

11.2.12.1 currentLogPdelayReqInterval: the current value of the logarithm to base 2 of the mean time interval, in seconds, between the sending of successive Pdelay_Req messages (see 11.5.2.2). This value is set in the LinkDelaySyncIntervalSetting state machine (see 11.2.17). The data type for currentLogPdelayReqInterval is Integer8.

11.2.12.2 initialLogPdelayReqInterval: the initial value of the logarithm to base 2 of the mean time interval, in seconds, between the sending of successive Pdelay_Req messages (see 11.5.2.2). The data type for initialLogPdelayReqInterval is Integer8.

11.2.12.3 pdelayReqInterval: a variable containing the mean Pdelay_Req message transmission interval for the port corresponding to this MD entity. The value is set in the LinkDelaySyncIntervalSetting state machine (see 11.2.17). The data type for pdelayReqInterval is UScaledNs.

11.2.12.4 allowedLostResponses: the number of Pdelay_Req messages for which a valid response is not received, above which a port is considered to not be exchanging peer delay messages with its neighbor. The

data type for `allowedLostResponses` is `UInteger16`. The required value of `allowedLostResponses` is given in 11.5.3.

11.2.12.5 `isMeasuringDelay`: a Boolean that is TRUE if the port is measuring link propagation delay. For a full-duplex, point-to-point link, the port is measuring link propagation delay if it is receiving `Pdelay_Resp` and `Pdelay_Resp_Follow_Up` messages from the port at the other end of the link (i.e., it performs the measurement using the peer delay mechanism).

11.2.12.6 `neighborPropDelayThresh`: the propagation time threshold, above which a port is not considered capable of participating in the IEEE 802.1AS protocol. If `neighborPropDelay` (see 10.2.4.7) exceeds `neighborPropDelayThresh`, then `asCapable` (see 11.2.12.4) is set to FALSE. The data type for `neighborPropDelayThresh` is `UScaledNs`.

11.2.12.7 `syncSequenceId`: the `sequenceId` for the next Sync message to be sent by this MD entity. The data type for `syncSequenceId` is `UInteger16`.

11.2.13 MDSyncReceiveSM state machine

11.2.13.1 State machine variables

The following variables are used in the state diagram of 11.2.13.3:

11.2.13.1.1 `followUpReceiptTimeoutTime`: a variable used to save the time at which the information conveyed by a received Sync message will be discarded if the associated `Follow_Up` message is not received by then. The data type for `syncReceiptTimeout` is `UScaledNs`.

11.2.13.1.2 `rcvdSync`: a Boolean variable that notifies the current state machine when a Sync message is received. This variable is reset by the current state machine.

11.2.13.1.3 `rcvdFollowUp`: a Boolean variable that notifies the current state machine when a `Follow_Up` message is received. This variable is reset by the current state machine.

11.2.13.1.4 `rcvdSyncPtr`: a pointer to a structure whose members contain the values of the fields of the Sync message whose receipt is indicated by `rcvdSync` (see 11.2.13.1.2).

11.2.13.1.5 `rcvdFollowUpPtr`: a pointer to a structure whose members contain the values of the fields of the `Follow_Up` message whose receipt is indicated by `rcvdFollowUp` (see 11.2.13.1.3).

11.2.13.1.6 `txMDSyncReceivePtr`: a pointer to a structure whose members contain the values of the parameters of an `MDSyncReceive` structure to be transmitted.

11.2.13.1.7 `upstreamSyncInterval`: the sync interval (see 10.6.2.1) for the upstream port that sent the received Sync message.

11.2.13.2 State machine functions

The following functions are used in the state diagram of 11.2.13.3:

11.2.13.2.1 `setMDSyncReceive()`: creates an `MDSyncReceive` structure, and returns a pointer to this structure. The members of this structure are set as follows:

- a) `followUpCorrectionField` is set equal to the `correctionField` (see 11.4.2.4) of the most recently received `FollowUp` message,
- b) `sourcePortIdentity` is set equal to the `sourcePortIdentity` (see 11.4.2.5) of the most recently received Sync message,

- c) `logMessageInterval` is set equal to the `logMessageInterval` (see 11.4.2.8) of the most recently received Sync message,
- d) `preciseOriginTimestamp` is set equal to the `preciseOriginTimestamp` (see 11.4.4.2.1) of the most recently received Follow_Up message,
- e) `rateRatio` is set equal to the quantity $(\text{cumulativeScaledRateOffset} \times 2^{-41}) + 1.0$, where the `cumulativeScaledRateOffset` field is for the most recently received Follow_Up message (see 11.4.4.3.6),
- f) `upstreamTxTime` is set equal to the `<syncEventIngressTimestamp>` for the most recently received Sync message, minus the mean propagation time on the link attached to this port (`neighborPropDelay`, see 10.2.4.7) divided by `neighborRateRatio` (see 10.2.4.6), minus `delayAsymmetry` (see 10.2.4.8) for this port divided by `rateRatio` [see e) above]. The `<syncEventIngressTimestamp>` is equal to the timestamp value measured relative to the timestamp measurement plane, minus any `ingressLatency` (see 8.4.3),

NOTE 1—The mean propagation time is divided by `neighborRateRatio` to convert it from the time base of the time-aware system at the other end of the attached link to the time base of the current time-aware system. The `delayAsymmetry` is divided by `rateRatio` to convert it from the time base of the grandmaster to the time base of the current time-aware system. The two quotients are then subtracted from `<syncEventIngressTimestamp>`, which is measured relative to the time base of the current time-aware system.

NOTE 2—The difference between the mean propagation time in the grandmaster time base, the time base of the time-aware system at the other end of the link, and the time base of the current time-aware system is usually negligible. The same is true of any `delayAsymmetry`. See NOTE 2 of 11.2.15.2.4.

- g) `gmTimeBaseIndicator` is set equal to the `gmTimeBaseIndicator` of the most recently received Follow_Up message (see 11.4.4),
- h) `lastGmPhaseChange` is set equal to the `lastGmPhaseChange` of the most recently received Follow_Up message (see 11.4.4), and
- i) `lastGmFreqChange` is set equal to the `lastGmFreqChange` of the most recently received Follow_Up message (see 11.4.4).

11.2.13.2.2 txMDSyncReceive (txMDSyncReceivePtr): transmits an `MDSyncReceive` structure to the `PortSyncSyncReceive` state machine of the `PortSync` entity of this port.

11.2.13.3 State diagram

The `MDSyncReceiveSM` state machine shall implement the function specified by the state diagram in Figure 11-6, the local variables specified in 11.2.13.1, the functions specified in 11.2.13.2, the structure specified in 11.2.10 and 10.2.2.1, the messages specified in 11.4, and the relevant global variables and functions specified in 10.2.3 through 10.2.5. The state machine receives Sync and Follow_Up messages, places the time-synchronization information in an `MDSyncReceive` structure, and sends the structure to the `PortSyncSyncReceive` state machine of the `PortSync` entity of this port.

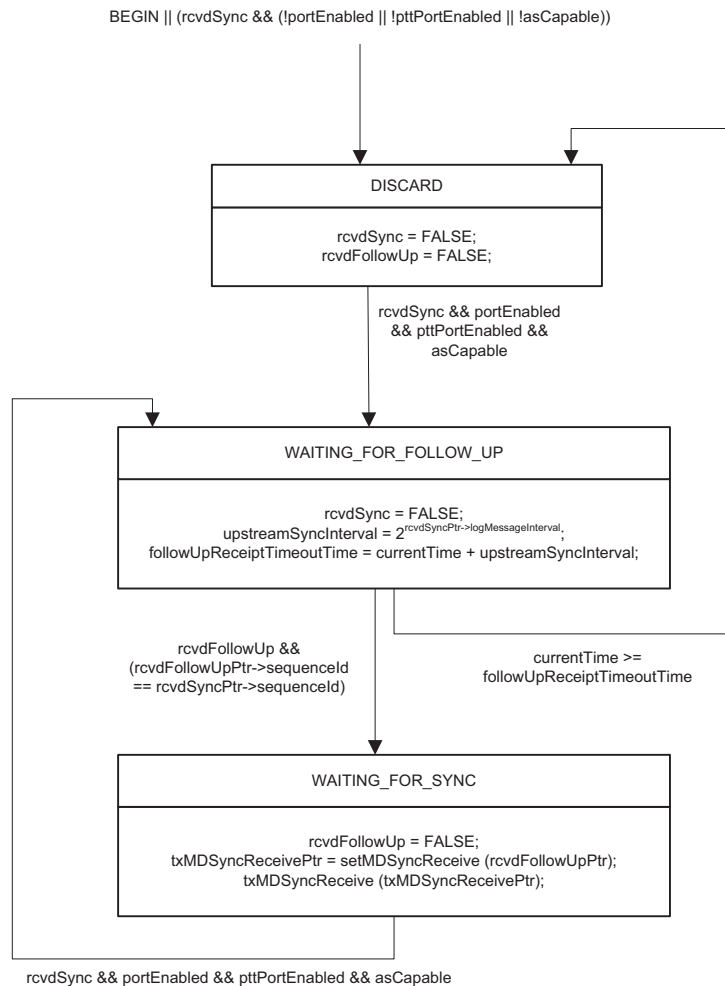

Figure 11-6—MDSyncReceiveSM state machine

11.2.14 MDSyncSendSM state machine

11.2.14.1 State machine variables

The following variables are used in the state diagram of 11.2.14.3:

11.2.14.1.1 rcvdMDSync: a Boolean variable that notifies the current state machine when an MDSyncSend structure is received. This variable is reset by the current state machine.

11.2.14.1.2 txSyncPtr: a pointer to a structure whose members contain the values of the fields of a Sync message to be transmitted.

11.2.14.1.3 rcvdMDTimestampReceive: a Boolean variable that notifies the current state machine when the <syncEventEgressTimestamp> (see 11.3.2.1) for a transmitted Sync message is received. This variable is reset by the current state machine.

11.2.14.1.4 rcvdMDTimestampReceivePtr: a pointer to the received MDTimestampReceive structure (see 11.2.9).

11.2.14.1.5 txFollowUpPtr: a pointer to a structure whose members contain the values of the fields of a Follow_Up message to be transmitted.

11.2.14.2 State machine functions

The following functions are used in the state diagram of 11.2.14.3:

11.2.14.2.1 setSync(): creates a structure whose parameters contain the fields (see 11.4 and its subclauses) of a Sync message to be transmitted, and returns a pointer to this structure. The parameters are set as follows:

- a) correctionField is set equal to 0,
- b) sourcePortIdentity is set equal to the sourcePortIdentity member of the most recently received MDSyncSend structure (see 10.2.2.1 and 11.2.11),
- c) sequenceId is set equal to syncSequenceId (see 11.2.12.4),
- d) logMessageInterval is set equal to the logMessageInterval member of the most recently received MDSyncSend structure (see 10.2.2.1 and 11.2.11), and
- e) remaining fields are set as specified in 11.4.2 and 11.4.3.

11.2.14.2.2 txSync (txSyncPtr): transmits a Sync message from this MD entity, whose fields contain the parameters in the structure pointed to by txSyncPtr (see 11.2.14.1.2).

11.2.14.2.3 setFollowUp(): creates a structure whose parameters contain the fields (see 11.4 and its subclauses) of a Follow_Up message to be transmitted, and returns a pointer to this structure. The parameters are set as follows:

- a) followUpCorrectionField is set equal to the sum of:
 - 1) the followUpCorrectionField member of the most recently received MDSyncSend structure (see 10.2.2.1 and 11.2.11)
 - 2) the quantity

$$\text{rateRatio} \times (\langle \text{syncEventEgressTimestamp} \rangle - \text{upstreamTxTime}),$$

where rateRatio is the rateRatio member of the most recently received MDSyncSend structure (see 10.2.2.1 and 11.2.11), upstreamTxTime is the upstreamTxTime member of the most recently received MDSyncSend structure (see 10.2.2.1 and 11.2.11), and $\langle \text{syncEventEgressTimestamp} \rangle$ is the timestamp pointed to by rcvdMDTimestampReceivePtr, corrected for egressLatency (see 8.4.3).

NOTE—If the time-aware system that contains this PortSync entity is a Bridge, the quantity

$$\langle \text{syncEventEgressTimestamp} \rangle - \text{upstreamTxTime}$$

is the sum of the residence time and link propagation delay on the upstream link, relative to the LocalClock entity, and the quantity

$$\text{rateRatio} \times (\langle \text{syncEventEgressTimestamp} \rangle - \text{upstreamTxTime})$$

is the sum of the residence time and link propagation delay on the upstream link, relative to the grandmaster (see 11.2.13.2.1 for details on the setting of upstreamTxTime).

- b) sourcePortIdentity is set equal to the sourcePortIdentity member of the most recently received MDSyncSend structure (see 10.2.2.1 and 11.2.11),
- c) sequenceId is set equal to syncSequenceId (see 11.2.13.1.6),

- d) `logMessageInterval` is set equal to the `logMessageInterval` member of the most recently received `MDSyncSend` structure (see 10.2.2.1 and 11.2.11),
- e) `preciseOriginTimestamp` is set equal to the `preciseOriginTimestamp` member of the most recently received `MDSyncSend` structure (see 10.2.2.1 and 11.2.11),
- f) `rateRatio` is set equal to the `rateRatio` member of the most recently received `MDSyncSend` structure (see 10.2.2.1 and 11.2.11),
- g) `gmTimeBaseIndicator` is set equal to the `gmTimeBaseIndicator` member of the most recently received `MDSyncSend` structure (see 10.2.2.1 and 11.2.11),
- h) `lastGmPhaseChange` is set equal to the `lastGmPhaseChange` member of the most recently received `MDSyncSend` structure (see 10.2.2.1 and 11.2.11),
- i) `lastGmFreqChange` is set equal to the `scaledLastGmFreqChange` member of the most recently received `MDSyncSend` structure (see 10.2.2.1 and 11.2.11), multiplied by 2^{41} , and
- j) remaining fields are set as specified in 11.4.2 and 11.4.3.

11.2.14.2.4 txFollowUp (txFollowUpPtr): transmits a `Follow_Up` message from this MD entity, whose fields contain the parameters in the structure pointed to by `txFollowUpPtr` (see 11.2.14.1.5).

11.2.14.3 State diagram

The `MDSyncSendSM` state machine shall implement the function specified by the state diagram in Figure 11-7; the local variables specified in 11.2.14.1; the functions specified in 11.2.14.2; the structures specified in 11.2.9, 11.2.11 and 10.2.2.1; the messages specified in 11.4; the MD entity global variables specified in 11.2.12; and the relevant global variables and functions specified in 10.2.3 through 10.2.5. The state machine receives an `MDSyncSend` structure from the `PortSyncSyncSend` state machine of the `PortSync` entity of this port and transmits a `Sync` and corresponding `Follow_Up` message.

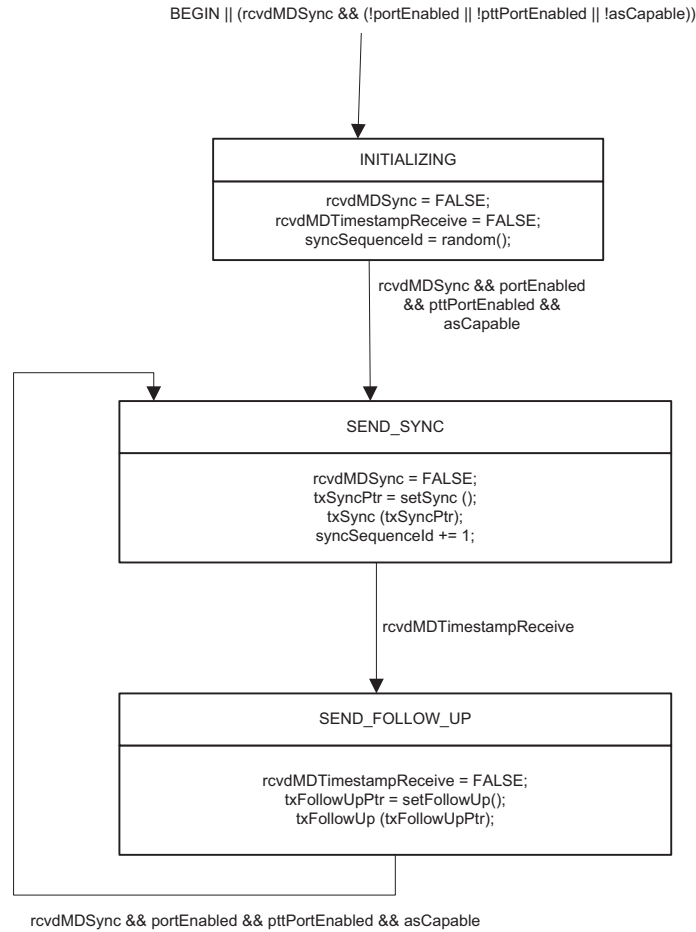

Figure 11-7—MDSyncSendSM state machine

11.2.15 MDPdelayReq state machine

11.2.15.1 State machine variables

The following variables are used in the state diagram of 11.2.15.3:

11.2.15.1.1 pdelayIntervalTimer: a variable used to save the time at which the Pdelay_Req interval timer is started, see Figure 11-8. A Pdelay_Req message is sent when this timer expires. The data type for pdelayIntervalTimer is UScaledNs.

11.2.15.1.2 rcvdPdelayResp: a Boolean variable that notifies the current state machine when a Pdelay_Resp message is received. This variable is reset by the current state machine.

11.2.15.1.3 rcvdPdelayRespPtr: a pointer to a structure whose members contain the values of the fields of the Pdelay_Resp message whose receipt is indicated by rcvdPdelayResp (see 11.2.15.1.2).

11.2.15.1.4 rcvdPdelayRespFollowUp: a Boolean variable that notifies the current state machine when a Pdelay_Resp_Follow_Up message is received. This variable is reset by the current state machine.

11.2.15.1.5 rcvdPdelayRespFollowUpPtr: a pointer to a structure whose members contain the values of the fields of the Pdelay_Resp_Follow_Up message whose receipt is indicated by rcvdPdelayRespFollowUp (see 11.2.15.1.4).

11.2.15.1.6 txPdelayReqPtr: a pointer to a structure whose members contain the values of the fields of a Pdelay_Req message to be transmitted.

11.2.15.1.7 rcvdMDTimestampReceive: a Boolean variable that notifies the current state machine when the <pdelayReqEventEgressTimestamp> (see 11.3.2.1) for a transmitted Pdelay_Req message is received. This variable is reset by the current state machine.

11.2.15.1.8 pdelayReqSequenceId: a variable that holds the sequenceId for the next Pdelay_Req message to be transmitted by this MD entity. The data type for pdelayReqSequenceId is UInteger16.

11.2.15.1.9 initPdelayRespReceived: a Boolean variable that indicates whether or not initial Pdelay_Resp and Pdelay_Resp_Follow_Up messages have been received when initializing the neighborRateRatio measurement. This variable is initialized to FALSE when the port initializes or re-initializes, and after a Pdelay_Resp and/or Pdelay_Resp_Follow_Up message are not received in response to a sent Pdelay_Req message.

11.2.15.1.10 lostResponses: a count of the number of consecutive Pdelay_Req messages sent by the port, for which Pdelay_Resp and/or Pdelay_Resp_Follow_Up messages are not received. The data type for lostResponses is UInteger16.

11.2.15.1.11 neighborRateRatioValid: a Boolean variable that indicates whether or not the function computePdelayRateRatio() (see 11.2.15.2.3) successfully computed neighborRateRatio (see 10.2.4.6).

11.2.15.2 State machine functions

The following functions are used in the state diagram of 11.2.15.3:

11.2.15.2.1 setPdelayReq(): creates a structure containing the parameters (see 11.4 and its subclauses) of a Pdelay_Req message to be transmitted, and returns a pointer, txPdelayReqPtr (see 11.2.15.1.6), to this structure. The parameters are set as follows:

- 1) sourcePortIdentity is set equal to the port identity of the port corresponding to this MD entity (see 8.5.2),
- 2) sequenceId is set equal to pdelayReqSequenceId (see 11.2.15.1.8), and
- 3) remaining parameters are set as specified in 11.4.2 and 11.4.5.

11.2.15.2.2 txPdelayReq(txPdelayReqPtr): transmits a Pdelay_Req message from the MD entity, containing the parameters in the structure pointed to by txPdelayReqPtr (see 11.2.15.1.6).

11.2.15.2.3 computePdelayRateRatio(): computes neighborRateRatio (see 10.2.4.6) using the following information conveyed by successive Pdelay_Resp and Pdelay_Resp_Follow_Up messages:

- a) The <pdelayRespEventIngressTimestamp> (see 11.3.2.1) values for the respective Pdelay_Resp messages
- b) The correctedResponderEventTimestamp values, whose date type is UScaledNs, obtained by adding the following fields of the received Pdelay_Resp_Follow_Up message:
 - 1) The seconds field of the responseOriginTimestamp field, multiplied by 10^9 ,
 - 2) The nanoseconds field of the responseOriginTimestamp parameter, and
 - 3) The correctionField, divided by 2^{16} .

Any scheme that uses the preceding information, along with any other information conveyed by the successive Pdelay_Resp and Pdelay_Resp_Follow_Up messages, to compute neighborRateRatio is

acceptable as long as the performance requirements specified in B.2.4 are met. If `neighborRateRatio` is successfully computed, the Boolean `neighborRateRatioValid` (see 11.2.15.1.11) is set to TRUE. If `neighborRateRatio` is not successfully computed (e.g., if the MD entity has not yet exchanged a sufficient number of peer delay messages with its peer), the Boolean `neighborRateRatioValid` is set to FALSE.

NOTE 1—As one example, `neighborRateRatio` can be estimated as the ratio of the elapsed time of the `LocalClock` entity of the time-aware system at the other end of the link attached to this port, to the elapsed time of the `LocalClock` entity of this time-aware system. This ratio can be computed for the time interval between a set of received `Pdelay_Resp` and `Pdelay_Resp_Follow_Up` messages and a second set of received `Pdelay_Resp` and `Pdelay_Resp_Follow_Up` messages some number of `Pdelay_Req` message transmission intervals later, i.e.,

$$\frac{\langle \text{correctedResponderEventTimestamp} \rangle_N - \langle \text{correctedResponderEventTimestamp} \rangle_0}{\langle \text{pdelayRespEventIngressTimestamp} \rangle_N - \langle \text{pdelayRespEventIngressTimestamp} \rangle_0}$$

where N is the number of `Pdelay_Req` message transmission intervals separating the first set of received `Pdelay_Resp` and `Pdelay_Resp_Follow_Up` messages and the second set, and the successive sets of received `Pdelay_Resp` and `Pdelay_Resp_Follow_Up` messages are indexed from 0 to N with the first set indexed 0.

NOTE 2—This function must account for non-receipt of `Pdelay_Resp` and/or `Pdelay_Resp_Follow_Up` for a `Pdelay_Req` message, and also for receipt of multiple `Pdelay_Resp` messages within one `Pdelay_Req` message transmission interval.

11.2.15.2.4 computePropTime(): computes the mean propagation delay on the link attached to this MD entity, D , and returns this value. D is given by Equation (11-5):

$$D = \frac{r \cdot (t_4 - t_1) - (t_3 - t_2)}{2} \quad (11-5)$$

where

t_4 = `<pdelayRespEventIngressTimestamp>` (see 11.3.2.1) for the `Pdelay_Resp` message received in response to the `Pdelay_Req` message sent by the MD entity, expressed in ns; the `<pdelayRespEventIngressTimestamp>` is equal to the timestamp value measured relative to the timestamp measurement plane, minus any `ingressLatency` (see 8.4.3)

t_1 = `<pdelayReqEventEgressTimestamp>` (see 11.3.2.1) for the `Pdelay_Req` message sent by the `P2PPort` entity, expressed in ns

t_2 = sum of (1) the ns field of the `requestReceiptTimestamp`, (2) the seconds field of the `requestReceiptTimestamp` multiplied by 10^9 , and (3) the correction field divided by 2^{16} (i.e., the correction field is expressed in ns plus fractional ns), of the `Pdelay_Resp` message received in response to the `Pdelay_Req` message sent by the MD entity

t_3 = sum of (1) the ns field of the `responseOriginTimestamp`, (2) the seconds field of the `responseOriginTimestamp` multiplied by 10^9 , and (3) the correction field divided by 2^{16} (i.e., the correction field is expressed in ns plus fractional ns), of the `Pdelay_Resp_Follow_Up` message received in response to the `Pdelay_Req` message sent by the MD entity

r = current value of `neighborRateRatio` for this MD entity (see 10.2.4.6)

Propagation delay averaging may be performed, as described in 11.1.2 by Equation (11-2), Equation (11-3), and Equation (11-4). In this case, the successive values of propagation delay computed using Equation (11-5) are input to either Equation (11-2) or Equation (11-4), and the computed average propagation delay is returned by this function.

NOTE 1—Equation (11-5) defines D as the mean propagation delay relative to the time base of the time-aware system at the other end of the attached link. It is divided by `neighborRateRatio` (see 10.2.4.6) to convert it to the time base of the current time-aware system when adding to `<syncEventIngressTimestamp>` to compute `upstreamTxTime` [see 11.2.13.2.1 f)].

NOTE 2—The difference between mean propagation delay relative to the grandmaster time base and relative to the time base of the time-aware system at the other end of the attached link is usually negligible. To see this, note that the former can be obtained from the latter by multiplying the latter by the ratio of the grandmaster frequency to the frequency of the LocalClock entity of the time-aware system at the other end of the link attached to this port. This ratio differs from 1 by 200 ppm or less. For example, for a worst-case frequency offset of the LocalClock entity of the time-aware system at the other end of the link, relative to the grandmaster, of 200 ppm, and a measured propagation time of 100 ns, the difference in D relative to the two time bases is 20 ps.

11.2.15.3 State diagram

The MDPdelayReq state machine shall implement the function specified by the state diagram in Figure 11-8, the local variables specified in 11.2.15.1, the functions specified in 11.2.15.2, the messages specified in 11.4, and the relevant global variables and functions specified in 11.2.12 and 10.2.3 through 10.2.5. This state machine is responsible for the following:

- a) Sending Pdelay_Req messages and restarting the pdelayIntervalTimer,
- b) Detecting that the peer mechanism is running,
- c) Detecting if Pdelay_Resp and/or Pdelay_Resp_Follow_Up messages corresponding to a Pdelay_Req message sent are not received,
- d) Detecting whether more than one Pdelay_Resp is received within one Pdelay_Req message transmission interval (see 11.5.2.2),
- e) Computing propagation time on the attached link when Pdelay_Resp and Pdelay_Resp_Follow_Up messages are received, and
- f) Computing the ratio of the frequency of the LocalClock entity of the time-aware system at the other end of the attached link to the frequency of the LocalClock entity of the current time-aware system.

NOTE—The ratio of the frequency of the LocalClock entity of the time-aware system at the other end of the attached link to the frequency of the LocalClock entity of the current time-aware system, pdelayRateRatio, retains its most recent value when a Pdelay_Resp and/or Pdelay_Resp_Follow_Up message is lost.

11.2.16 MDPdelayResp state machine

11.2.16.1 State machine variables

The following variables are used in the state diagram of 11.2.16.3:

11.2.16.1.1 rcvdPdelayReq: a Boolean variable that notifies the current state machine when a Pdelay_Req message is received. This variable is reset by the current state machine.

11.2.16.1.2 rcvdMDTimestampReceive: a Boolean variable that notifies the current state machine when the <pdelayRespEventEgressTimestamp> (see 11.3.2.1) for a transmitted Pdelay_Resp message is received. This variable is reset by the current state machine.

11.2.16.1.3 txPdelayRespPtr: a pointer to a structure whose members contain the values of the fields of a Pdelay_Resp message to be transmitted.

11.2.16.1.4 txPdelayRespFollowUpPtr: a pointer to a structure whose members contain the values of the fields of a Pdelay_Resp_Follow_Up message to be transmitted.

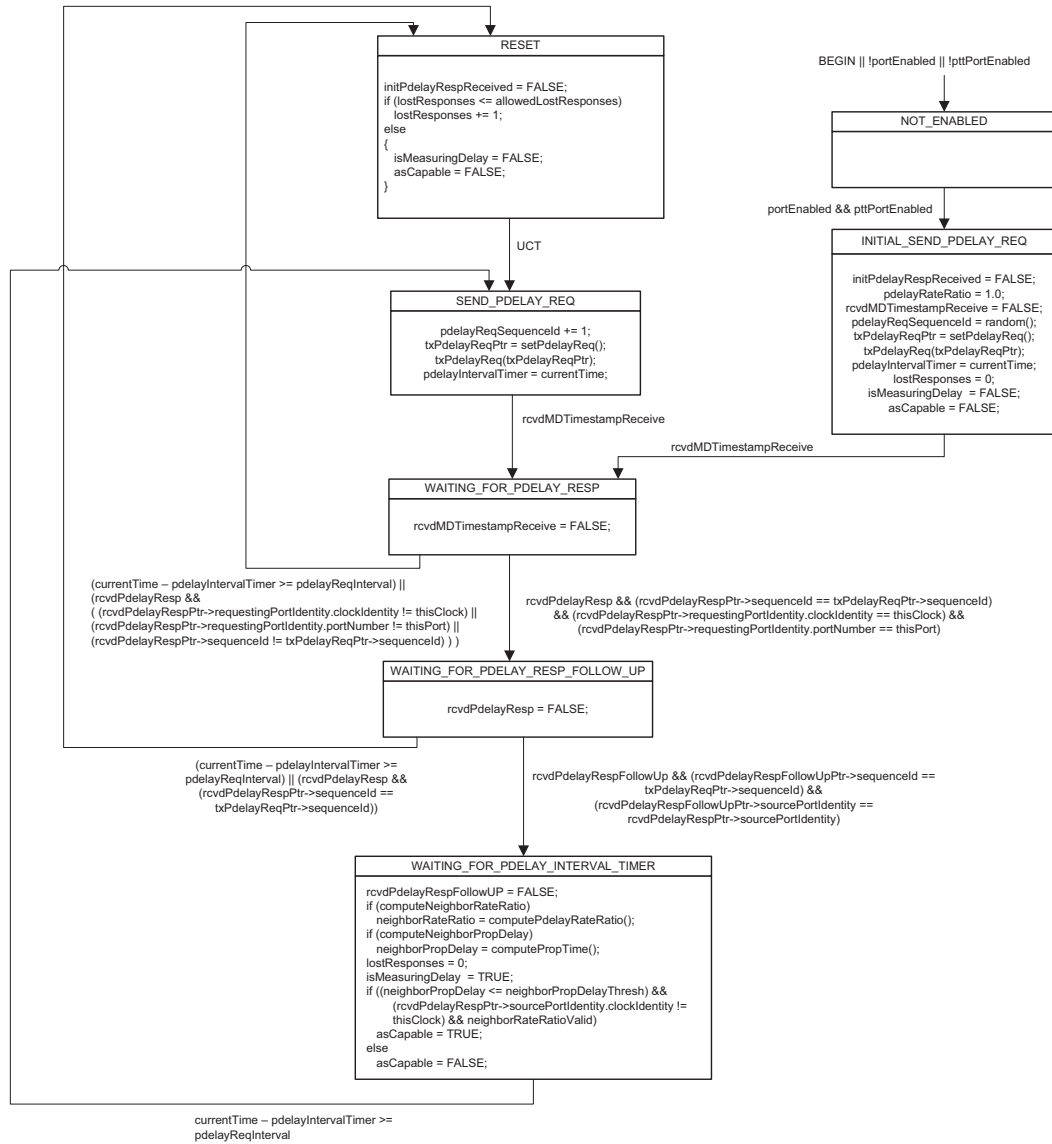

Figure 11-8—MDPdelayReq state machine

11.2.16.2 State machine functions

The following functions are used in the state diagram of 11.2.16.3:

11.2.16.2.1 setPdelayResp(): creates a structure containing the parameters (see 11.4 and its subclauses) of a Pdelay_Resp message to be transmitted, and returns a pointer, txPdelayRespPtr (see 11.2.16.1.3), to this structure. The parameters are set as follows:

- sourcePortIdentity is set equal to the port identity of the port corresponding to this MD entity (see 8.5.2),
- sequenceId is set equal to the sequenceId field of the corresponding Pdelay_Req message,

- c) requestReceiptTimestamp is set equal to the <pdelayReqEventIngressTimestamp> (see 11.3.2) of the corresponding Pdelay_Req message, with any fractional ns portion truncated,
- d) correctionField is set equal to the fractional ns portion of the <pdelayReqEventIngressTimestamp> of the corresponding Pdelay_Req message,
- e) requestingPortIdentity is set equal to the sourcePortIdentity field of the corresponding Pdelay_Req message, and
- f) remaining parameters are set as specified in 11.4.2 and 11.4.6.

11.2.16.2.2 txPdelayResp(txPdelayRespPtr): transmits a Pdelay_Resp message from the MD entity, containing the parameters in the structure pointed to by txPdelayRespPtr (see 11.2.16.1.3).

11.2.16.2.3 setPdelayRespFollowUp(): creates a structure containing the parameters (see 11.4 and its subclauses) of a Pdelay_Resp_Follow_Up message to be transmitted, and returns a pointer, txPdelayRespFollowUpPtr (see 11.2.16.1.4), to this structure. The parameters are set as follows:

- a) sourcePortIdentity is set equal to the port identity of the port corresponding to this MD entity (see 8.5.2),
- b) sequenceId is set equal to the sequenceId field of the corresponding Pdelay_Req message,
- c) responseOriginTimestamp is set equal to the <pdelayRespEventEgressTimestamp> (see 11.3.2) of the corresponding Pdelay_Resp message, with any fractional ns truncated,
- d) correctionField is set equal to the fractional ns portion of the <pdelayRespEventEgressTimestamp> of the corresponding Pdelay_Resp message,
- e) requestingPortIdentity is set equal to the sourcePortIdentity field of the corresponding Pdelay_Req message, and
- f) remaining parameters are set as specified in 11.4.2 and 11.4.6.

11.2.16.2.4 txFollowUp(txFollowUpPtr): transmits a Pdelay_Resp_Follow_Up message from the P2PPort entity containing the parameters in the structure pointed to by txPdelayRespFollowUpPtr (see 11.2.16.1.4).

11.2.16.3 State diagram

The MDPdelayResp state machine shall implement the function specified by the state diagram in Figure 11-9, the local variables specified in 11.2.16.1, the functions specified in 11.2.16.2, the messages specified in 11.4, and the relevant global variables and functions specified in 10.2.3 through 10.2.5. This state machine is responsible for responding to Pdelay_Req messages, received from the MD entity at the other end of the attached link, with Pdelay_Resp and Pdelay_Resp_Follow_Up messages.

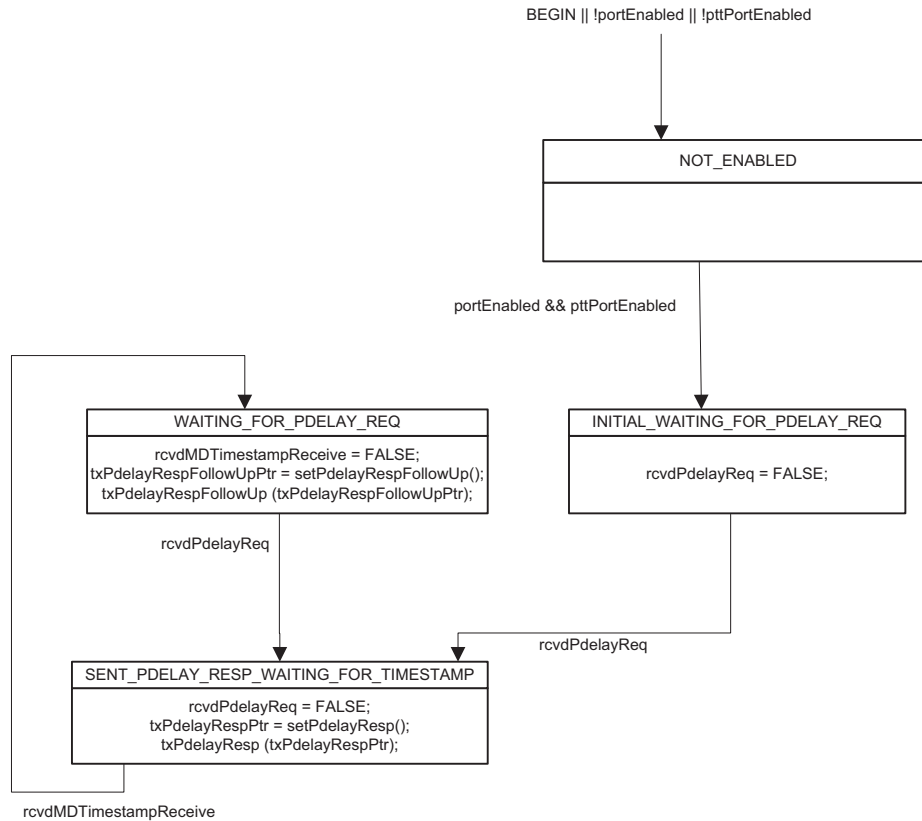

Figure 11-9—MDPdelayResp state machine

11.2.17 LinkDelaySyncIntervalSetting state machine

11.2.17.1 State machine variables

The following variables are used in the state diagram of 11.2.17.2:

11.2.17.1.1 rcvdSignalingMsg1: a Boolean variable that notifies the current state machine when a Signaling message that contains a Message Interval Request TLV (see 10.5.4.3) is received. This variable is reset by the current state machine.

11.2.17.1.2 rcvdSignalingPtr: a pointer to a structure whose members contain the values of the fields of the received Signaling message that contains a Message Interval Request TLV (see 10.5.4.3).

11.2.17.2 State diagram

The LinkDelaySyncIntervalSetting state machine shall implement the function specified by the state diagram in Figure 11-10, the local variables specified in 11.2.17.1, the messages specified in 10.5 and 11.4, the relevant global variables specified in 10.2.4 and 11.2.12, and the relevant timing attributes specified in 10.6 and 11.5. This state machine is responsible for setting the global variables that give the duration of the mean intervals between successive Sync and successive Pdelay_Req messages, both at initialization and in response to the receipt of a Signaling message that contains a Message Interval Request TLV (see 10.5.4.3).

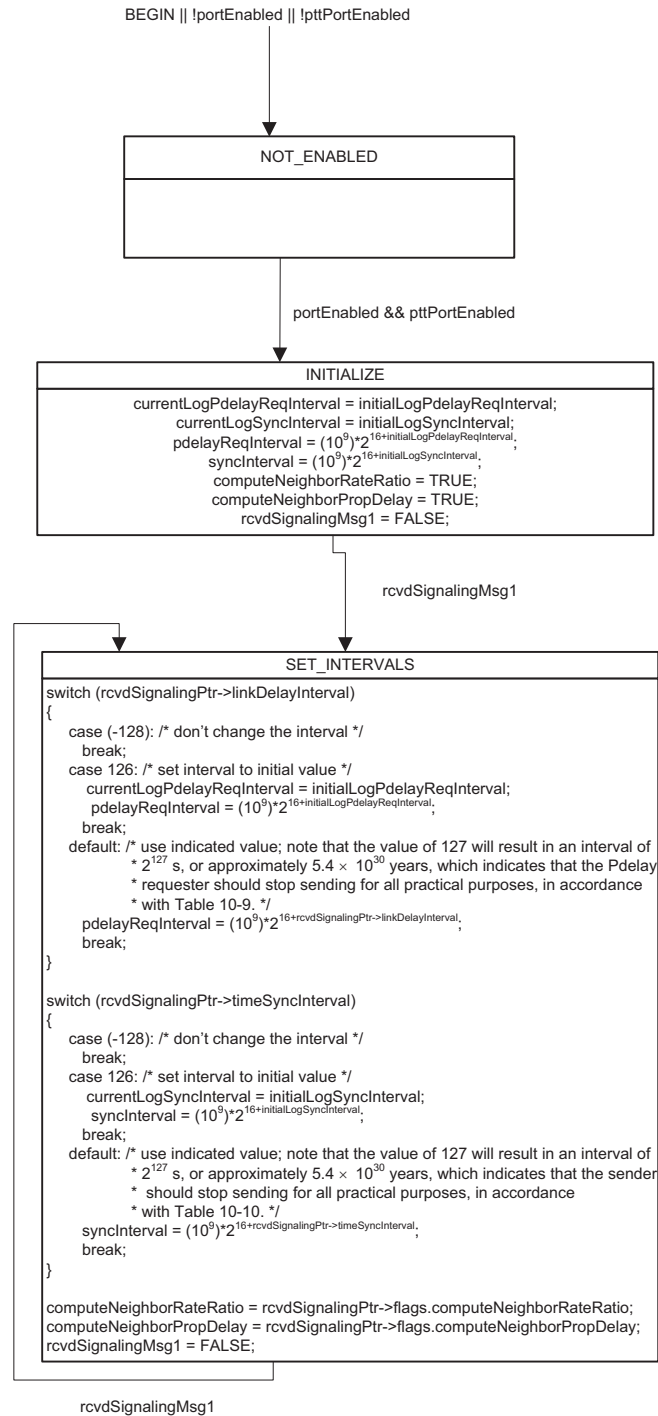

Figure 11-10—LinkDelaySyncIntervalSetting state machine

11.3 Message attributes

11.3.1 General

This subclause describes attributes of the Sync, Follow_Up, Pdelay_Req, Pdelay_Resp, and Pdelay_Resp_Follow_Up messages that are not described in 8.4.2.

11.3.2 Message types contained in each message class

11.3.2.1 Event message class

The event message class contains the following message types:

- a) Sync: A Sync message contains time-synchronization information that originates at a ClockMaster entity. The appearance of a Sync message at the reference plane of the port corresponding to an MD entity is an event to which the LocalClock assigns a timestamp, the <syncEventIngressTimestamp> or <syncEventEgressTimestamp>, based on the time of the LocalClock. The <syncEventIngressTimestamp> and <syncEventEgressTimestamp> are measured relative to the timestamp measurement plane; the MD entity corrects them for ingress and egress latencies, respectively (see 8.4.3). The Sync message is followed by a Follow_Up message containing synchronization information that is based in part on the sum of the <syncEventEgressTimestamp> and any egressLatency (see 8.4.3).
- b) Pdelay_Req: A Pdelay_Req message is transmitted by an MD entity to another MD entity as part of the peer delay mechanism (see 11.2.15 and 11.2.16.2) to determine the delay on the link between them. The appearance of a Pdelay_Req message at the reference plane of the port of an MD entity is an event to which the LocalClock assigns a timestamp, the <pdelayReqEventIngressTimestamp> or <pdelayReqEventEgressTimestamp>, based on the time of the LocalClock. The <pdelayReqEventIngressTimestamp> and <pdelayReqEventEgressTimestamp> are measured relative to the timestamp measurement plane; the MD entity corrects them for ingress and egress latencies, respectively (see 8.4.3).
- c) Pdelay_Resp: A Pdelay_Resp message is transmitted by an MD entity to another MD entity in response to the receipt of a Pdelay_Req message. The Pdelay_Resp message contains the <pdelay-req-ingress-timestamp> of the Pdelay_Req message that it is transmitted in response to. The appearance of a Pdelay_Resp message at the reference plane of the port of an MD entity is an event to which the LocalClock assigns a timestamp, the <pdelayRespEventIngressTimestamp> or <pdelayRespEventEgressTimestamp>, based on the time of the LocalClock. The <pdelayRespEventIngressTimestamp> and <pdelayRespEventEgressTimestamp> are measured relative to the timestamp measurement plane; the MD entity corrects them for ingress and egress latencies, respectively (see 8.4.3). The Pdelay_Resp message is followed by a Pdelay_Resp_Follow_Up message containing the sum of the <pdelayRespEventEgressTimestamp> and any egressLatency (see 8.4.3).

Event messages shall be assigned the timestamps previously defined, in accordance with 8.4.3.

11.3.2.2 General message class

The general message class contains the following message types:

- a) Follow_Up: A Follow_Up message communicates the value of the <syncEventEgressTimestamp> for the associated Sync message.
- b) Pdelay_Resp_Follow_Up: A Pdelay_Resp_Follow_Up message communicates the value of the <PdelayRespEventEgressTimestamp> for the associated Pdelay_Resp message.

General messages are not required to be timestamped.

11.3.3 VLAN tag

A frame that carries an IEEE 802.1AS message shall not have a VLAN tag nor a priority tag.

11.3.4 Addresses

The destination address of Sync, Follow_Up, Pdelay_Req, Pdelay_Resp, and Pdelay_Resp_Follow_Up messages shall be the reserved multicast address given in Table 11-1.

Table 11-1—Destination address for Sync, Follow_Up, Pdelay_Req, Pdelay_Resp, and Pdelay_Resp_Follow_Up messages

Destination address
01-80-C2-00-00-0E
NOTE—This address is taken from Table 8-1 of IEEE Std 802.1Q-2005.

All Sync, Follow_Up, Pdelay_Req, Pdelay_Resp, and Pdelay_Resp_Follow_Up messages shall use the MAC address of the respective egress physical port as the source address.

11.3.5 Ethertype

The Ethertype of Sync, Follow_Up, Pdelay_Req, Pdelay_Resp, and Pdelay_Resp_Follow_Up messages shall be the Ethertype given in Table 11-2.

Table 11-2—Ethertype for Sync, Follow_Up, Pdelay_Req, Pdelay_Resp, and Pdelay_Resp_Follow_Up messages

Ethertype
88F7 ₁₆

11.3.6 Subtype

The subtype of the Sync, Follow_Up, Pdelay_Req, Pdelay_Resp, and Pdelay_Resp_Follow_Up messages is indicated by the transportSpecific field (see 10.5.2.2.1)

NOTE—The subtype for all PTP messages is indicated by the transportSpecific field.

11.3.7 Source port identity

The Sync and Follow_Up messages each contain a sourcePortIdentity field, see 11.4.2.5, that identifies the time-aware end station where the information contained in each message originated (see 10.4.6).

The Pdelay_Req, Pdelay_Resp, and Pdelay_Resp_Follow_Up messages each contain a sourcePortIdentity field (see 11.4.2.5) that identifies the egress port (see 8.5) on which the respective message is sent.

11.3.8 Sequence number

Each MD entity shall maintain a separate sequenceId pool for each of the message types Sync and Pdelay_Req, respectively.

Each Sync and Pdelay_Req message contains a sequenceId field, see 11.4.2.6, that carries the message sequence number. The sequenceId of a Sync message shall be one greater than the sequenceId of the previous Sync message sent by the transmitting port, subject to the constraints of the rollover of the

UInteger16 data type used for the sequenceId field. The sequenceId of a Pdelay_Req message shall be one greater than the sequenceId of the previous Pdelay_Req message sent by the transmitting port, subject to the constraints of the rollover of the UInteger16 data type used for the sequenceId field.

Separate pools of sequenceId are not maintained for the following message types:

- a) Pdelay_Resp
- b) Follow_Up
- c) Pdelay_Resp_Follow_Up

For these exceptions, the sequenceId value is specified in 11.4.2.6, Table 11-6.

11.3.9 Event message timestamp point

The message timestamp point for a PTP event message shall be the beginning of the first symbol following the start of frame delimiter.

11.4 Message formats

11.4.1 General

The PTP messages Sync, Follow_Up, Pdelay_Req, Pdelay_Resp, and Pdelay_Resp_Follow_Up shall each have a header, body, and if present, a suffix that contains one or more TLVs (see 10.5.2, 11.4.3, 11.4.4, 11.4.5, 11.4.6, 11.4.7, and Clause 14 of IEEE 1588-2008). Reserved fields shall be transmitted with all bits of the field 0 and ignored by the receiver, unless otherwise specified. The data type of the field shall be the type indicated in brackets in the title of each subclause.

This subclause defines the Follow_Up information TLV, which is carried by the Follow_Up message (see 11.4.4.3). The Follow_Up information TLV shall be the first TLV of a Follow_Up message. If a time-aware system cannot parse a TLV, it shall ignore it and attempt to parse the next TLV (see 14.1 of IEEE Std 1588-2008).

NOTE—The standard Ethernet header and FCS (18 bytes total) must be added to each message.

11.4.2 Header

The common header for the PTP messages Sync, Follow_Up, Pdelay_Req, Pdelay_Resp, and Pdelay_Resp_Follow_Up shall be as specified in 10.5.2 and its subclauses, except as noted in the following subclauses.

11.4.2.1 messageType (Enumeration4)

The value indicates the type of the message, as defined in Table 11-3.

The most significant bit of the message ID field divides this field in half between event and general messages, i.e., it is 0 for event messages and 1 for general messages.

NOTE—The reserved nibble immediately following messageType is reserved for future expansion of the messageType field.

Table 11-3—Values for messageType field

Message type	Message class	Value
Sync	Event	0x0
Pdelay_Req	Event	0x2
Pdelay_Resp	Event	0x3
Follow_Up	General	0x8
Pdelay_Resp_Follow_Up	General	0xA
NOTE—Other values for the messageType field, except for 0xB that is used for the Announce message and 0xC that is used for the Signaling message (see 10.5.2.2.2), are not used in this standard.		

11.4.2.2 messageLength (UInteger16)

The value is the total number of octets that form the PTP message. The counted octets start with and include the first octet of the header and terminate with and include the last octet of the last TLV or, if there are no TLVs, with the last octet of the message as defined in this subclause.

NOTE—See 10.5.2.2.4 for an example.

11.4.2.3 Flags (Octet2)

The value of the bits of the array are defined in Table 11-4. For message types where the bit is not defined in Table 11-4, the value of the bit is set to FALSE.

Table 11-4—Values of flag bits

Octet	Bit	Message type	Name	Value
0	1	Sync, Pdelay_Resp	twoStepFlag	Reserved as TRUE, ignored on reception

11.4.2.4 correctionField (Integer64)

The correctionField is the value of the correction as specified in Table 11-5, measured in nanoseconds and multiplied by 2^{16} . For example, 2.5 ns is represented as 0x00000000000028000.

A value of one in all bits, except the most significant, of the field, indicates that the correction is too big to be represented.

11.4.2.5 sourcePortIdentity (PortIdentity)

The value is the portIdentity of the egress port (see 8.5.2) on which the respective message is sent.

Table 11-5—Value of correction field

Message type	Value
Follow_Up	Corrections for fractional nanoseconds (see 10.2.8 and Figure 10-5), difference between preciseOriginTimestamp field and current synchronized time (see 11.2.14.2.3 and Figure 11-7), and asymmetry corrections (see 8.3, 11.2.13.2.1, and 11.2.14.2.3; the quantity delayAsymmetry is used in the computation of upstreamTxTime in 11.2.13.2.1, and upstreamTxTime is used in computing an addition to the correction field in 11.2.14.2.3)
Pdelay_Req, Pdelay_Resp, Pdelay_Resp_Follow_Up	Corrections for fractional nanoseconds (see Figure 11-8 and Figure 11-9)
NOTE—IEEE Std 1588-2008 describes asymmetry corrections for the Pdelay_Req and Pdelay_Resp messages. However, the peer delay mechanism computes the mean propagation delay. In the case here where the communication path is a full-duplex, point-to-point link, these corrections cancel in the mean propagation delay computation and therefore are not needed.	

11.4.2.6 sequenceId (UInteger16)

The value is assigned by the originator of the message in conformance with 11.3.8, except in the case of Follow_Up, Pdelay_Resp, and Pdelay_Resp_Follow_Up messages. The sequenceId field values for these exceptions are defined in the state diagrams given in the figures referenced in Table 11-6.

Table 11-6—References for sequenceId value exceptions

Message type	Reference
Follow_Up	See 11.2.14 and Figure 11-7
Pdelay_Resp	See 11.2.16.2 and Figure 11-9
Pdelay_Resp_Follow_Up	See 11.2.16.2 and Figure 11-9

11.4.2.7 control (UInteger8)

The value is as specified in Table 11-7.

Table 11-7—Value of control field

Message type	Value
Sync	0x0
Follow_Up	0x2
Announce, Pdelay_Req, Pdelay_Resp, Pdelay_Resp_Follow_Up	0x5

11.4.2.8 logMessageInterval (Integer8)

For Sync and Follow_Up messages, the value is the value of currentLogSyncInterval, see 10.2.4.3 and 10.6.2.3. For Pdelay_Req messages, the value is the value of currentLogPdelayReqInterval. For Pdelay_Resp and Pdelay_Resp_Follow_Up messages, the value is reserved as 0x7F and ignored on reception.

11.4.3 Sync

The fields of the Sync message shall be as specified in Table 11-8.

Table 11-8—Sync message fields

Bits								Octets	Offset
8	7	6	5	4	3	2	1		
header (see 11.4.2)								34	0
reserved								10	34

11.4.4 Follow_Up

11.4.4.1 General Follow_Up message specifications

The fields of the Follow_Up message shall be as specified in Table 11-9 and 11.4.4.2 and its subclauses.

Table 11-9—Follow_Up message fields

Bits								Octets	Offset
8	7	6	5	4	3	2	1		
header (see 11.4.2)								34	0
preciseOriginTimestamp								10	34
Follow_Up information TLV								32	44

11.4.4.2 Follow_Up message field specifications

11.4.4.2.1 preciseOriginTimestamp (Timestamp)

The value of the preciseOriginTimestamp field is the sourceTime of the ClockMaster entity of the grandmaster, when the associated time synchronization event message was sent by that grandmaster, with any fractional nanoseconds truncated (see 10.2.8).

The sum of the correction fields in the Follow_Up and associated time synchronization event messages, added to the preciseOriginTimestamp field of the Follow_Up message, is the value of the synchronized time corresponding to the <syncEventEgressTimestamp> at the time-aware system that sent the associated time synchronization event message, including any fractional nanoseconds.

11.4.4.2.2 Follow_Up information TLV

The Follow_Up message carries the Follow_Up information TLV, defined in 11.4.4.3. This TLV shall be the first TLV after the fixed fields.

11.4.4.3 Follow_Up information TLV

11.4.4.3.1 General

The fields of the Follow_Up information TLV shall be as specified in Table 11-10 and in 11.4.4.3.2 through 11.4.4.3.9. This TLV is a standard organization extension TLV for the Follow_Up message, as specified in 14.3 of IEEE Std 1588-2008.

Table 11-10—Follow_Up information TLV

Bits								Octets	Offset
8	7	6	5	4	3	2	1		
tlvType								2	0
lengthField								2	2
organizationId								3	4
organizationSubType								3	7
cumulativeScaledRateOffset								4	10
gmTimeBaseIndicator								2	14
lastGmPhaseChange								12	16
scaledLastGmFreqChange								4	28

11.4.4.3.2 tlvType (Enumeration16)

The value of the tlvType field is 0x3.

NOTE—This is the value that indicates the TLV is a vendor and standard organization extension TLV, as specified in 14.3.2.1 of IEEE Std 1588-2008. The value is specified there as ORGANIZATION_EXTENSION, whose value is 0x3.

11.4.4.3.3 lengthField (UInteger16)

The value of the lengthField is 28.

11.4.4.3.4 organizationId (Octet3)

The value of organizationId is 00-80-C2.

11.4.4.3.5 organizationSubType (Enumeration24)

The value of organizationSubType is 1.

11.4.4.3.6 cumulativeScaledRateOffset (Integer32)

The value of cumulativeScaledRateOffset is equal to $(\text{rateRatio} - 1.0) \times (2^{41})$, truncated to the next smaller signed integer, where rateRatio is the ratio of the frequency of the grandMaster to the frequency of the LocalClock entity in the time-aware system that sends the message.

NOTE—The above scaling allows the representation of fractional frequency offsets in the range $[-(2^{-10} - 2^{-41}), 2^{-10} - 2^{-41}]$, with granularity of 2^{-41} . This range is approximately $[-9.766 \times 10^{-4}, 9.766 \times 10^{-4}]$.

11.4.4.3.7 gmTimeBaseIndicator (UInteger16)

The value of gmTimeBaseIndicator is the timeBaseIndicator of the ClockSource entity for the current grandmaster (see 9.2.2.2).

NOTE—The timeBaseIndicator is supplied by the ClockSource entity to the ClockMaster entity via the ClockSourceTime.invoke function (see 9.2.2.2).

11.4.4.3.8 lastGmPhaseChange (ScaledNs)

The value of lastGmPhaseChange is the time of the current grandmaster minus the time of the previous grandmaster, at the time that the current grandmaster became grandmaster. The value is copied from the lastGmPhaseChange member of the MDSyncSend structure whose receipt causes the MD entity to send the Follow_Up message (see 11.2.11).

11.4.4.3.9 scaledLastGmFreqChange (Integer32)

The value of scaledLastGmFreqChange is the fractional frequency offset of the current grandmaster relative to the previous grandmaster, at the time that the current grandmaster became grandmaster, or relative to itself prior to the last change in gmTimeBaseIndicator, multiplied by 2^{41} and truncated to the next smaller signed integer. The value is obtained by multiplying the lastGmFreqChange member of MDSyncSend whose receipt causes the MD entity to send the Follow_Up message (see 11.2.11) by 2^{41} , and truncating to the next smaller signed integer.

NOTE—The above scaling allows the representation of fractional frequency offsets in the range $[-(2^{-10} - 2^{-41}), 2^{-10} - 2^{-41}]$, with granularity of 2^{-41} . This range is approximately $[-9.766 \times 10^{-4}, 9.766 \times 10^{-4}]$.

11.4.5 Pdelay_Req message

The fields of the Pdelay_Req message shall be as specified in Table 11-11.

Table 11-11—Pdelay_Req message fields

Bits								Octets	Offset
8	7	6	5	4	3	2	1		
header (see 11.4.2)								34	0
reserved								10	34
reserved								10	44

11.4.6 Pdelay_Resp message

11.4.6.1 General Pdelay_Resp message specifications

The fields of the Pdelay_Resp message shall be as specified in Table 11-12 and 11.4.6.2 and its subclauses.

Table 11-12—Pdelay_Resp message fields

Bits								Octets	Offset
8	7	6	5	4	3	2	1		
header (see 11.4.2)								34	0
requestReceiptTimestamp								10	34
requestingPortIdentity								10	44

11.4.6.2 Pdelay_Resp message field specifications

11.4.6.2.1 requestReceiptTimestamp (Timestamp)

The value is the seconds and nanoseconds portion of the <pdelayReqEventIngressTimestamp> of the associated Pdelay_Req message, see 11.2.16.2.

11.4.6.2.2 requestingPortIdentity (PortIdentity)

The value is the value of the sourcePortIdentity field of the associated Pdelay_Req message, see 11.2.16.2.

11.4.7 Pdelay_Resp_Follow_Up message

11.4.7.1 General Pdelay_Resp_Follow_Up message specifications

The fields of the Pdelay_Resp_Follow_Up message shall be as specified in Table 11-13 and 11.4.7.2 and its subclauses.

Table 11-13—Pdelay_Resp_Follow_Up message fields

Bits								Octets	Offset
8	7	6	5	4	3	2	1		
header (see 11.4.2)								34	0
responseOriginTimestamp								10	34
requestingPortIdentity								10	44

11.4.7.2 Pdelay_Resp_Follow_Up message field specifications

11.4.7.2.1 responseOriginTimestamp (Timestamp)

The value is the seconds and nanoseconds portion of the <pdelayRespEventEgressTimestamp> of the associated Pdelay_Resp message, see 11.2.16.2.

11.4.7.2.2 requestingPortIdentity (PortIdentity)

The value is the value of the sourcePortIdentity field of the associated Pdelay_Req message, see 11.2.16.2.

11.5 Protocol timing characterization

11.5.1 General

This subclause specifies timing attributes for the media-dependent sublayer specified in this clause.

11.5.2 Message transmission intervals

11.5.2.1 General interval specification

The mean time interval between successive Pdelay_Req messages is represented as the logarithm to the base 2 of this time interval measured in seconds. The value of this logarithmic attribute shall be as specified in 11.5.2.2.

The mean time interval between successive Sync messages shall be as specified in 10.6.2.1, 10.6.2.3, and 11.5.2.3.

11.5.2.2 Pdelay_Req message transmission interval

The initialLogPdelayReqInterval specifies the following:

- a) The mean time interval between successive Pdelay_Req messages sent over a link when the port is initialized, and
- b) The value the mean time interval between successive Pdelay_Req messages is set to when a message interval request TLV is received with the linkDelayIntervalField set to 126 (see 11.2.17).

The currentLogPdelayReqInterval specifies the current value of the mean time interval between successive Pdelay_Req messages. The default value of initialLogPdelayReqInterval is 0. Every port supports the value 127; the port does not send Pdelay_Req messages when currentLogPdelayReqInterval has this value (see 11.2.17). A port may support other values, except for the reserved values –128 through –125, inclusive, and 124 through 126, inclusive. A port shall ignore requests (see 11.2.17) for unsupported values. The initialLogPdelayReqInterval and currentLogPdelayReqInterval are per-port attributes.

NOTE 1—The value of initialLogPdelayReqInterval is the value of the mean time interval between successive Pdelay_Req messages when the port is initialized. The value of the mean time interval between successive Pdelay_Req messages may be changed, e.g., if the port receives a Signaling message that carries a message interval request TLV, see 10.5.4.3, and the current value is stored in currentLogPdelayReqInterval. The value of the mean time interval between successive Pdelay_Req messages can be reset to the initial value, e.g., by a message interval request TLV for which the value of the field linkDelayInterval is 126, see 10.5.4.3.6.

NOTE 2—A port that requests (using a Signaling message that contains a message interval request TLV, see 10.5.4 and 11.2.17) that the port at the other end of the attached link set its currentLogPdelayReqInterval to a specific value can determine if the request was honored by examining the logMessageInterval field of subsequent received Pdelay_Req messages.

11.5.2.3 Sync message transmission interval default value

The default value of `initialLogSyncInterval` (see 10.6.2.3) is `-3`. Every port supports the value `127`; the port does not send Sync messages when `currentLogSyncInterval` has this value (see 11.2.17). A port may support other values, except for the reserved values `-128` through `-125`, inclusive, and `124` through `126`, inclusive. A port ignores requests (see 11.2.17) for unsupported values.

NOTE—A port that requests (using a Signaling message that contains a message interval request TLV, see 10.5.4 and 11.2.17) that the port at the other end of the attached link set its `currentLogSyncInterval` to a specific value can determine if the request was honored by examining the `logMessageInterval` field of subsequent received Sync messages.

11.5.3 `allowedLostResponses`

The variable `allowedLostResponse` (see 11.2.12.4) is the number of `Pdelay_Req` messages for which a valid response is not received, above which a port is considered to not be exchanging peer delay messages with its neighbor. The value of `allowedLostResponses` shall be `3`.

12. Media-dependent layer specification for IEEE 802.11 links

12.1 Overview

Accurate synchronized time is distributed across a domain through time measurements between adjacent time-aware systems in a bridged LAN. Time is communicated from the root of the clock spanning tree (i.e., the grandmaster) to the leaves of the tree, by recursively propagating time from a leaf-facing “master” port to some number of root-facing “slave” ports in devices at the next level of the tree through measurements made across the links connecting the devices. While the time semantics are consistent across the time-aware bridged LAN, the method for communicating synchronized time from a master port to the immediate downstream link partner varies depending on the type of link interconnecting the two stations/Bridges.

This clause specifies the interface primitives and state machines that provide accurate synchronized time across wireless IEEE 802.11 links as part of a bridged LAN. This clause builds upon time measurement features defined in IEEE P802.11v (D15.0, September 2010), and makes no distinction between stations with an Access Point function and stations without an Access Point function.

12.1.1 IEEE P802.11v timing measurement procedure

IEEE P802.11v (D15.0, September 2010) defines a family of wireless measurements, including “timing measurement,” which captures timestamps of the transmit time and receive time of a round-trip message exchange between associated WLAN stations.

In contrast to the protocol defined for full-duplex point-to-point links, this clause does not define any new frames nor the transmission of any frames. Rather, it makes use of a MAC Layer Management Entity (MLME) interface, which causes the IEEE 802.11 layer to not only take timestamps of measurement frames as they are transmitted and received, but to also *generate* and *consume* the measurement frames, all within the IEEE 802.11 MLME layer, and then to provide timestamp information from the MLME to this media-dependent layer through a set of well-defined service primitives. However, as an aid to the reader, the protocol and frames used by the IEEE 802.11 MLME for time measurement are described briefly as follows and illustrated in Figure 12-1.

Time measurement is accomplished through a round-trip frame exchange. The first frame of the round-trip measurement (the “request” frame) is generated within the IEEE 802.11 MLME when the MLME-TIMINGMSMT.request primitive is invoked by the requesting station. As defined by IEEE Std 802.11-2007, upon receipt of the resulting unicast (action) frame, the receiving station transmits an IEEE 802.11 ACK control frame to the requesting station. Four timestamps are captured during this two-frame exchange, as follows:

- a) $t1$ is when (in the requesting station’s time base) the request frame is transmitted
- b) $t2$ is when (in the responding station’s time base) the request frame is received
- c) $t3$ is when (in the responding station’s time base) the ACK control frame is transmitted
- d) $t4$ is when (in the requesting station’s time base) the ACK control frame is received

When the requester initiates a Timing measurement request, it passes the $t1$ and $t4$ timestamps (and other end-to-end synchronization information) from the previous measurement to the responder. A pair of tokens are passed in each request, one to identify the current measurement and the other to allow the responder to associate the timestamp information with the previous measurement.

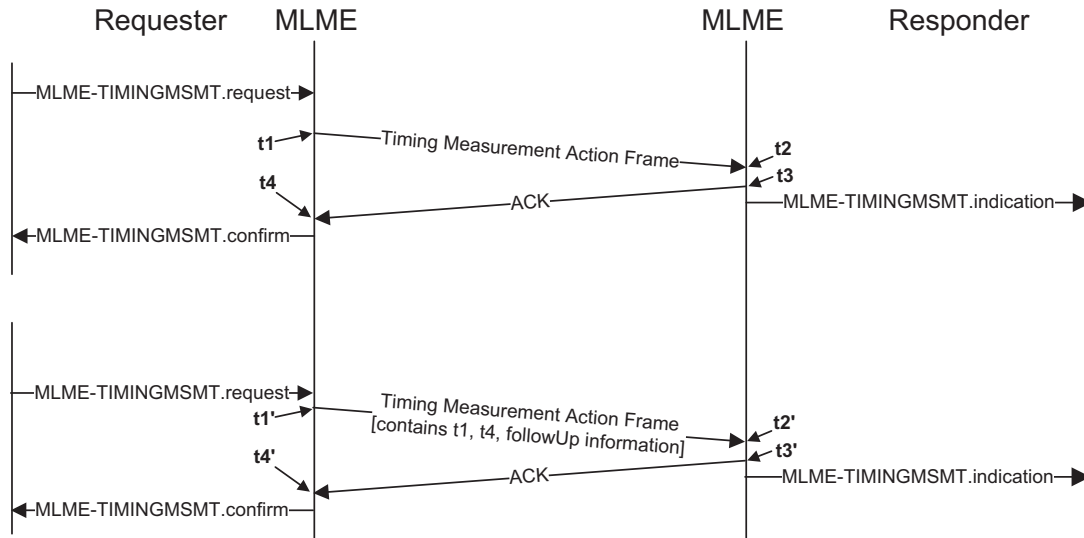

Figure 12-1—Timing measurement procedure for IEEE 802.11 links

Note that, unlike point-to-point full-duplex ports, IEEE 802.11 ports do not compute the link delay measurements in both directions since only a port in the Slave state makes use of that information. As a result, a port that transitions from the Master state to the Slave state (e.g., due to selection of a new grandmaster), may collect a number of link delay measurements and perform averaging or other filtering before achieving the desired accuracy.

12.1.2 Layering for IEEE 802.11 links

The *media-dependent* (MD) entity is tailored to the link technology and is responsible for translating the PortSync entity's media-independent actions to media-dependent PDUs or primitives as necessary for communicating synchronized time from the master port over the link to a single slave port. In the case of an IEEE 802.11 link, this one-to-one relationship between the MD entities of the master and slave implies that if the one physical IEEE 802.11 port is associated with multiple stations, each association requires its own instantiation of the IEEE 802.1AS PortSync entity and MD entity. The MLME-TIMINGMSMT service primitives defined in IEEE P802.11v (D15.0, September 2010) are used to perform timing measurements between a master IEEE 802.11 station and associated IEEE 802.11 slave station. Figure 12-2 illustrates how the MD entity interacts with the higher and lower layers.

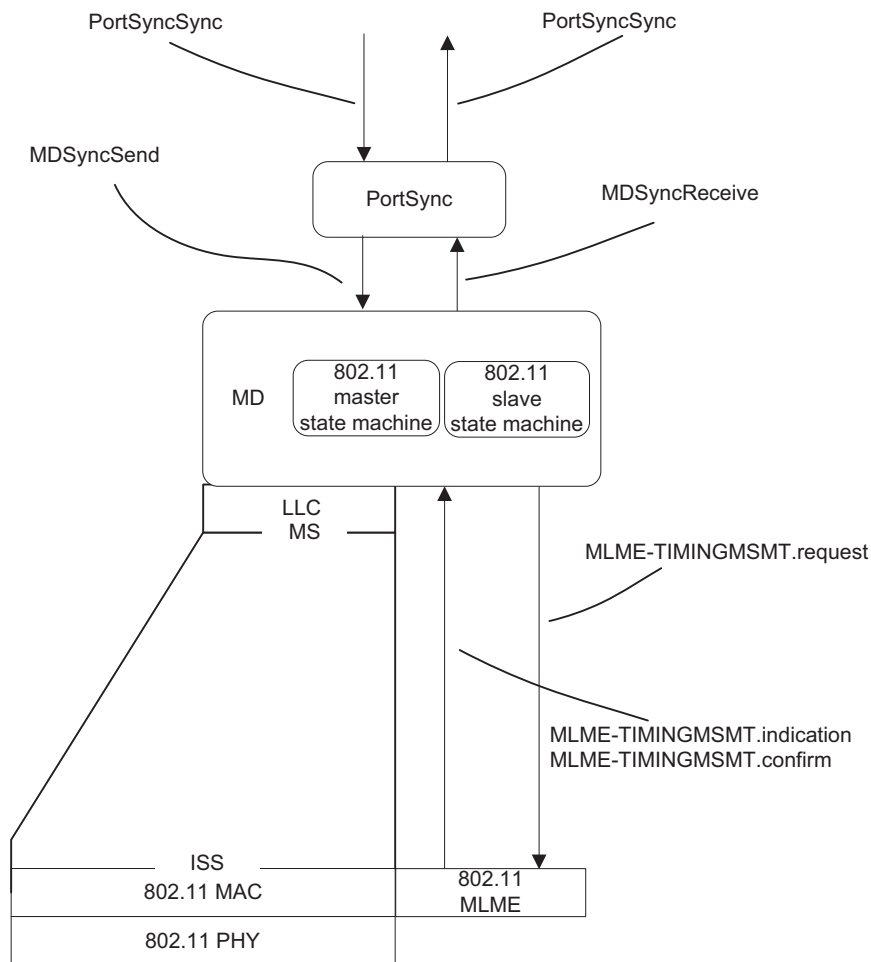

Figure 12-2—Media-dependent and lower entities in stations with IEEE 802.11 links

12.2 Messages

All media-dependent frames are generated and consumed by the lower-layer IEEE 802.11 MLME and thus none are defined here. Also, since the IEEE 802.11 event messages are timestamped by the MAC/PHY, the timestamp point is defined in IEEE P802.11v (D15.0, September 2010) as well. Media-independent messages, i.e., Announce and Signaling messages, are transmitted using the unicast address of the WLAN station instead of the group address defined in 10.4.3.

12.3 Determination of asCapable

The per-port global variable asCapable shall be set to FALSE if the *timing measurement* bit in the Extended Capabilities information element defined in Table 7-35a of IEEE P802.11v (D15.0, September 2010) indicates that the peer IEEE 802.11 station is incapable of participating in the timing measurement protocol. Otherwise, asCapable may be set to TRUE.

12.4 State machines

12.4.1 Media-dependent master state machine

12.4.1.1 Overview

The MD entity of an IEEE 802.11 port whose port role is MasterPort (see Table 10-1) shall behave in a manner that is indistinguishable, relative to an observer external to a system, from a strict implementation of the state diagram in Figure 12-3, the local variables specified in 12.4.1.3, the functions specified in 12.4.1.4, the shared variables specified in 12.4.1.5, and the primitives defined in 12.4.1.6.

The master state machine is responsible for initiating a time measurement whenever the PortSync entity requests it do so, as indicated by the rcvMDSync Boolean. The master state machine invokes the IEEE 802.11 MLME-TIMINGMSMT.request primitive and waits for the subsequent MLME-TIMINGMSMT.confirm primitive. It collects local timestamp information from the measurement ($t1$ and $t4$, provided by the confirm primitive) and includes the information in the subsequent request. See 8.4.3 for more information on timestamps.

12.4.1.2 State diagram

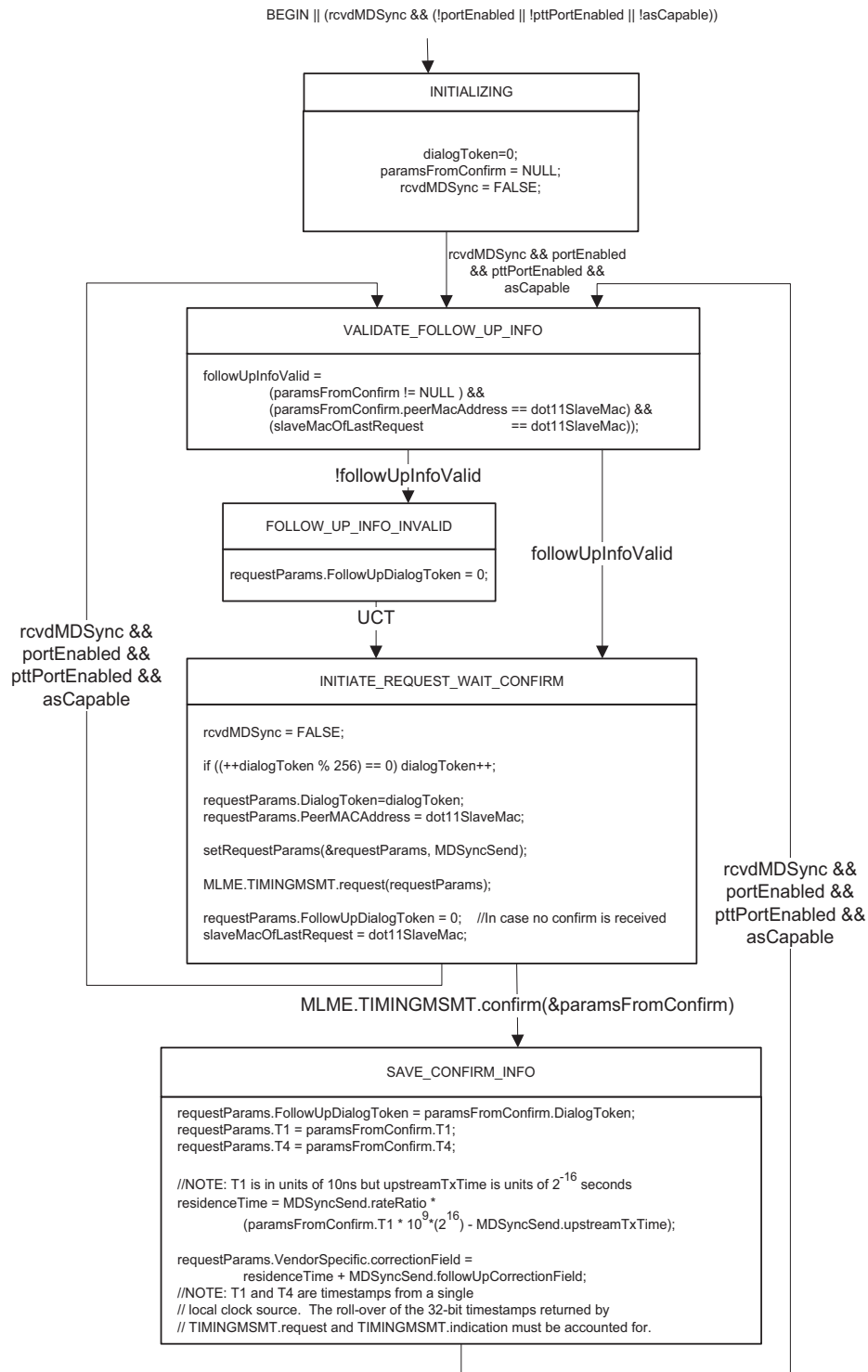

Figure 12-3—Master state machine

12.4.1.3 State machine local variables

- a) **dialogToken**: an unsigned 8-bit integer used to identify a measurement from among those preceding and following it.
- b) **followUpInfoValid**: a Boolean variable indicating whether the FollowUp information (e.g., timestamps and rateRatio) and the link partner are unchanged since the last timing measurement.
- c) **requestParams**: a structure whose members contain the values of the fields of the MLME-TIMINGMSMT.request primitive.
- d) **paramsFromConfirm**: a structure whose members contain the values of the fields of the MLME-TIMINGMSMT.confirm primitive.
- e) **dot11SlaveMac**: the MAC address of the station associated with the current port.
- f) **slaveMacOfLastRequest**: the MAC address of the station of the previous request, used to validate FollowUp information.
- g) **residenceTime**: a temporary variable that holds the computation of the time between receipt of the last synchronization information and transmission of synchronization information.
- h) **rcvdMDSync**: a Boolean variable that is set to TRUE when an MDSyncSend structure is provided by the PortSync entity.

12.4.1.4 State machine functions

- a) **setRequestParams**(&requestParams, MDSyncSend): assigns values to the parameters of the request primitive of MLME-TIMINGMSMT (see 12.4.1.6) as follows:
 - 1) Members of the FollowUpInformation member of the VendorSpecific information element, as defined in 12.5, are assigned as defined in 11.4.4 with the exception of the correctionField which is assigned as shown in the Master state machine in 12.4.1.2.
 - 2) The other fields of the VendorSpecific information element are assigned as follows:
 - i) ElementID is assigned the value 221 as defined in Table 7-26 (Element IDs) of IEEE Std 802.11-2007, indicating that the information element is of type Vendor Specific.
 - ii) The Length field is set to 80.

NOTE—This is equal to the length of the Follow_Up payload defined in 11.4.4 (including the common header) plus the length of the OUI and Type fields (see Figure 12-5).

- iii) The OUI field is set to 00-80-C2.
- iv) The Type field is set to 0.
- 3) MaxT1Error, MaxT4Error are set to zero.
- 4) All other members are left unchanged.

12.4.1.5 Shared Variables

- a) **MDSyncSend**: a structure as defined in 10.2.2.1.
- b) **portEnabled**: a Boolean as defined in 10.2.4.11.
- c) **pttPortEnabled**: a Boolean as defined in 10.2.4.12.
- d) **asCapable**: a Boolean whose value is specified in 12.3.

12.4.1.6 Master primitives

12.4.1.6.1 MLME-TIMINGMSMT.request

The MLME-TIMINGMSMT request primitive is used by a master station to initiate a timing measurement and also communicates timestamps $t1$ and $t4$ captured by the master during a previous measurement.

Its parameters are as follows:

MLME-TIMINGMSMT.request(
 PeerMACAddress,
 DialogToken,
 FollowUpDialogToken,
 T1,
 MaxT1Error,
 T4,
 MaxT4Error,
 VendorSpecific)

Table 12-1—Parameters of MLME-TIMINGMSMT.request

Name	Type	Valid range	Description
PeerMACAddress	MACAddress	N/A	The address of the peer MAC entity with which the Timing Measurement is initiated.
DialogToken	UInteger8	1–255	The dialog token used to identify this Timing Measurement transaction.
FollowUpDialog-Token	UInteger8	0–255	The dialog token of a previous Timing Measurement from which the FollowUpInformation is derived.
T1	UInteger32	0–(2 ³² –1)	Transmit (time of departure) timestamp <i>t1</i> from the time measurement indicated by the FollowUpDialogToken. In units of 10 ns.
MaxT1Error	Integer	0–255	Timestamp error, in units of 10 ns.
T4	UInteger32	0–(2 ³² –1)	Receive (time of arrival) timestamp <i>t4</i> from the time measurement indicated by the FollowUpDialogToken. In units of 10 ns.
MaxT4Error	Integer	0–255	Timestamp error, in units of 10 ns.
VendorSpecific	N/A	N/A	A Vendor Specific information element containing various time-synchronization parameters, including an <i>entire</i> Follow_Up message, as defined in 12.5.

Refer to IEEE P802.11v (D15.0, September 2010) for more information on the MLME primitives.

12.4.1.6.2 MLME-TIMINGMSMT.confirm

The MLME-TIMINGMSMT.confirm primitive indicates that a timing measurement request has completed.

Its parameters are as follows:

MLME-TIMINGMSMT.confirm(
 PeerMACAddress,
 DialogToken,
 T1,
 MaxT1Error,
 T4,
 MaxT4Error)

Table 12-2—Parameters of MLME-TIMINGMSMST.confirm

Name	Type	Valid range	Description
PeerMACAddress	MACAddress	N/A	The address of the peer MAC entity, which acknowledges the receipt of the Timing Measurement action frame.
DialogToken	Integer	1–255	The dialog token to identify the Timing Measurement transaction.
T1	UInteger32	0–(2 ³² –1)	The transmit timestamp <i>t1</i> in units of 10 ns.
MaxT1Error	UInteger8	0–255	Maximum error of timestamp <i>t1</i> in units of 10 ns.
T4	UInteger32	0–(2 ³² –1)	The receive timestamp <i>t4</i> in units of 10 ns.
MaxT4Error	UInteger8	0–255	Maximum error of timestamp <i>t4</i> in units of 10 ns.

Refer to IEEE P802.11v (D15.0, September 2010) for more information on this MLME primitive.

12.4.2 Media-dependent slave state machine

12.4.2.1 Overview

The MD entity of an IEEE 802.11 port whose port role is SlavePort or PassivePort (see 10.3.6) shall behave in a manner that is indistinguishable, relative to an observer external to a system, from a strict implementation of the state diagram in 12.4.2.2, the local variables specified in 12.4.2.3, the functions specified in 12.4.2.4, the shared variables specified in 12.4.2.5, and the primitives defined in 12.4.2.6.

The slave state machine is responsible for collecting information from Timing measurement indication, constructing MDSyncReceive structure with the relevant information, and passing the structure to the PortSync entity for further processing. In order to do this, the state machine saves locally captured timestamps (i.e., *t2* and *t3*) received in the indication, associating them with the timestamps sent from the master port in a future indication (i.e., *t1* and *t4*).

12.4.2.2 State diagram

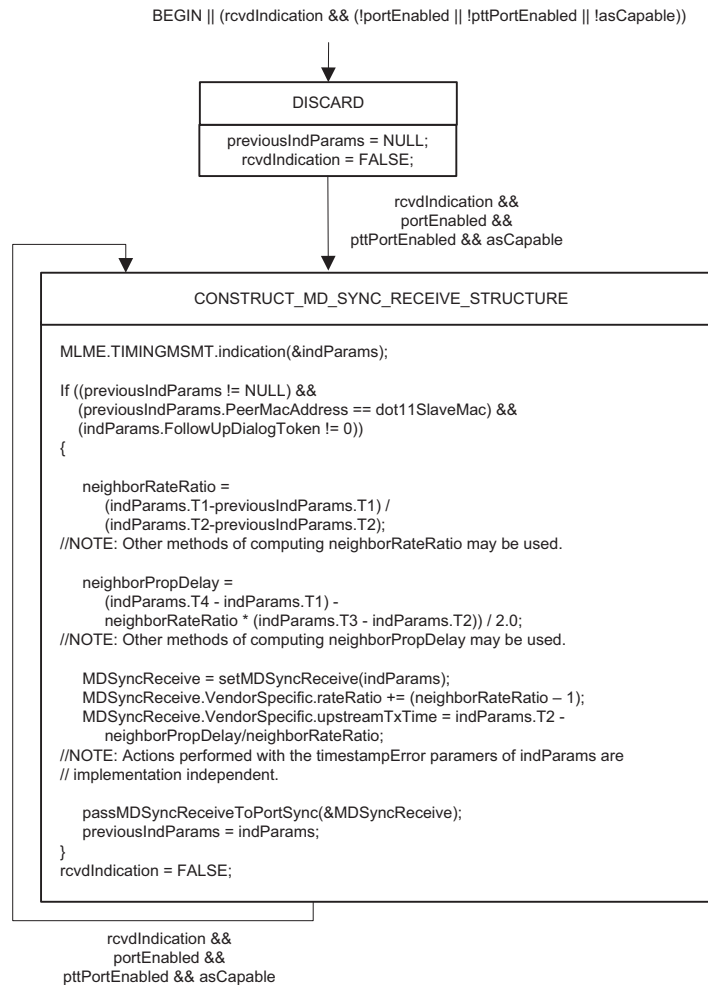

Figure 12-4—Slave state machine

While quantities are shown to be computed from information in consecutive indications, an implementation may choose to compute over longer intervals as long as the clock performance requirements of Annex B are met.

12.4.2.3 State machine local variables

- indParams**: a structure whose members contain the values of the fields of the MLME-TIMINGMSMT.indication primitive, as defined in 12.4.2.6.
- previousIndParams**: a structure with members identical to those of indParams, used to save parameters from the previous indication.
- neighborRateRatio**: the measured ratio of the frequency of the LocalClock entity of the remote system to the frequency of the LocalClock entity of this system. The data type is Double.
- rcvdIndication**: a Boolean which is set to TRUE when the MLME-TIMINGMSMT.indication is received.

12.4.2.4 State machine functions

- a) **setMDSyncReceive**(indParams): creates an MDSyncReceive structure and returns the structure. All fields are assigned from FollowUpInformation (contained in the VendorSpecific information element) of indParams as in 11.2.13.2.1.
- b) **passMDSyncReceiveToPortSync**(): passes an MDSyncReceive structure to the PortSync entity of this port.

12.4.2.5 State machine shared variables

- a) **MDSyncReceive**: a structure used for passing information between MD and PortSync, as defined in 10.2.2.2.
- b) **portEnabled**: a Boolean as defined in 10.2.4.
- c) **pttPortEnabled**: a Boolean as defined in 10.2.4.
- d) **asCapable**: a Boolean as defined in 12.3.
- e) **neighborPropDelay**: the delay over the link to the associated WLAN station as defined in 10.2.4.7.

12.4.2.6 Slave primitives

The MLME-TIMINGMSMT.indication primitive is received by a slave station as the natural result of the peer master station issuing the corresponding request primitive, and carries the same parameters plus local timestamp information.

Its parameters are as follows:

```
MLME-TIMINGMSMT.indication (  
    PeerMACAddress,  
    DialogToken,  
    FollowUpDialogToken,  
    T1,  
    MaxT1Error,  
    T4,  
    MaxT4Error,  
    T2,  
    MaxT2Error,  
    T3,  
    MaxT3Error,  
    VendorSpecific)
```

Table 12-3—Parameters of MLME-TIMINGMSMT.indication

Name	Type	Valid range	Description
PeerMACAddress	MACAddress	N/A	The address of the peer MAC entity from which the Timing Measurement was initiated.
DialogToken	UInteger8	1–255	The dialog token used to identify this Timing Measurement.
FollowUpDialog-Token	UInteger8	0–255	The dialog token of a Timing Measurement to which the indication is a follow on.
T1	UInteger32	0–2 ³² –1	Transmit timestamp <i>t1</i> from the time measurement indicated by the FollowUpDialog Token.
MaxT1Error	UInteger8	0–255	Error of the timestamp in units of 10 ns.
T4	UInteger32	0–2 ³² –1	Receive timestamp <i>t4</i> from the time measurement indicated by the FollowUpDialog Token.
MaxT4Error	UInteger8	0–255	Error of the timestamp in units of 10 ns.
T2	UInteger32	0–2 ³² –1	Receive timestamp <i>t2</i> captured from the current time measurement.
MaxT2Error	UInteger8	0–255	Error of the timestamp in units of 10 ns.
T3	UInteger32	0–2 ³² –1	Transmit timestamp <i>t3</i> captured from the current time measurement.
MaxT3Error	UInteger8	0–255	Error of the timestamp in units of 10 ns.
VendorSpecific	N/A	N/A	A Vendor Specific information element containing various time-synchronization parameters (including a full Follow_Up message), as defined in 12.5.

12.5 Format of VendorSpecific information element

The IEEE 802.11 MLME request and indication primitives for timing measurement support an ability to carry data transparently between stations using the VendorSpecific information element. The Type field within the VendorSpecific Content identifies the type of information that follows the Type field. See Figure 12-5 and Table 12-4.

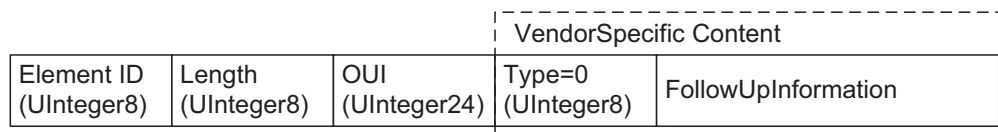

Figure 12-5—Format of VendorSpecific information element when Type = 0

Table 12-4—Values of the Type field in the VendorSpecific information element

Value	Description
0	The Type field is followed by FollowUp-Information
1–255	Reserved

This mechanism is used to carry end-to-end link-independent timing information from the master port to the associated slave port, including `preciseOriginTimestamp`, `rateRatio`, `correctionField`, and other fields of the Follow-Up message, as described in 12.4.1.4. For consistency, all of these fields are packed into the `FollowUpInformation` field using exactly the same format as used for full-duplex point-to-point links. In other words, the master state machine communicates an entire `Follow_Up` message (see 11.4.4) using this mechanism. The `Type` field, illustrated in Figure 12-5, identifies this use of the OUI within the `VendorSpecific` information element. Table 12-4 lists values for the `Type` field.

12.6 Synchronization message interval

12.6.1 General synchronization message interval specification

The mean time interval between successive synchronization messages shall be as specified in 10.6.2.1, 10.6.2.3, and 12.6.2.

12.6.2 Synchronization message interval default value

The default value of `initialLogSyncInterval` (see 10.6.2.3) is `-3`. Every port supports the value `127`; the port does not send `Sync` messages when `currentLogSyncInterval` has this value (see 11.2.17). A port may support other values, except for the reserved values `-128` through `-125`, inclusive, and `124` through `126`, inclusive. A port ignores requests (see 11.2.17) for unsupported values.

Processing of the message interval request TLV carried in a `Signaling` message (see 10.5.4) shall be supported, as specified by the `LinkDelaySyncIntervalSetting` state machine of 11.2.17 (see Figure 11-10), except that: the `linkDelayInterval` (which is not relevant to IEEE 802.11 ports) is set to `-128` by the sender of the `Signaling` message, the `linkDelayInterval` is ignored by the receiver, and unsupported values of `timeSyncInterval` are ignored by the receiver.

NOTE 1—A port that requests (using a `Signaling` message that contains a message interval request TLV, see 10.5.4 and 11.2.17) that the port at the other end of the attached link set its `currentLogSyncInterval` to a specific value can determine if the request was honored by examining the `logMessageInterval` field of a `FollowUpInformation` contained in the `VendorSpecific` information element of a subsequent MLME indication primitive.

NOTE 2—The time interval between every pair of adjacent timing measurements is not guaranteed to be precisely the same. Some variation is expected, due to factors such as the MAC protocol (e.g., delay in accessing the medium and/or packet retries) and the power state of the associated station. However, timestamp `T1` is not captured when `TIMINGMSMT.request` is invoked, but only after the action frame resulting from the request is actually transmitted.

13. Media-dependent layer specification for interface to IEEE 802.3 Ethernet passive optical network link

13.1 Overview

13.1.1 General

This clause specifies the service interface primitives, state machines, and message formats that provide accurate synchronized time across IEEE 802.3 Ethernet passive optical network (EPON) links, through the use of the timing process and measurements specified in 64.2.1.1 and 64.3.2.4 of IEEE Std 802.3-2008, and 77.2.1.1 and 76.1.2 of IEEE Std 802.3av-2009. For purposes of this clause, an EPON link is an EPON that contains one optical line terminal (OLT) and associated optical network units (ONUs).

A time-aware system contains at most one ONU, but may contain more than one OLT (i.e., a time-aware system is a clock slave to at most one EPON link, but may be a clock master to more than one EPON link).

13.1.2 Description of the EPON timing process

The timing process in EPON relies on the 32-bit counters (see 64.2.2.2 of IEEE Std 802.3-2008 and 77.2.2.2 of IEEE Std 802.3av-2009) at both the OLT and the ONU. The 32-bit counter used by EPON is the LocalClock entity of the time-aware system. These counters increment every time_quantum, which is equal to 16 ns (see 64.2.2.1 of IEEE Std 802.3-2008 and 77.2.2.1 of IEEE Std 802.3av-2009). IEEE Std 802.3-2008 and IEEE Std 802.3av-2009 define multipoint control protocol (MPCP), which is one of the protocols that enables MAC clients to communicate over a point-to-multipoint optical network. When either the clock master (OLT) or the clock slave (ONU) transmits an MPCP data unit (MPCPDU), its counter value is mapped into the timestamp field. Clause 64 of IEEE Std 802.3-2008 and Clause 77 of IEEE Std 802.3av-2009 specify the EPON timing mechanism.

13.1.3 Best master selection

13.1.3.1 General

An EPON link contains one OLT and the associated ONUs. The OLT is the clock master and the associated ONUs are clock slaves. The OLT initiates the time synchronization as a requester. The ONUs are the responders of the time synchronization. This means that the invocation of BMCA results in the OLT having the port role MasterPort and the ONU having the port role SlavePort (see 10.3.1 and Table 10-1), regardless of the attributes of time-aware systems downstream from the ONU. This behavior is achieved using the acceptable master table feature defined in 17.6 of IEEE Std 1588-2008.

A time-aware system that contains an ONU port shall maintain a configured table, the acceptableMasterTable, and a per-port Boolean variable acceptableMasterTableEnabled. The data type of acceptableMasterTable is AcceptableMasterTable (see 13.1.3.2).

13.1.3.2 AcceptableMasterTable

The AcceptableMasterTable type represents a table of AcceptableMaster entries.

```
struct AcceptableMasterTable {
    UInteger16 maxTableSize;
    UInteger16 actualTableSize;
    AcceptableMaster[actualTableSize] acceptableMaster;
}
```

The `maxTableSize` member is the maximum size of the `AcceptableMasterTable`. The `actualTableSizeMember` is the actual size of the `AcceptableMasterTable`. The `AcceptableMaster` array contains a list of `AcceptableMaster` ports. The value of `maxTableSize` is implementation specific. `actualTableSize` shall be less than or equal to `maxTableSize`.

An `AcceptableMasterTable` is configurable and may contain a number of `AcceptableMaster` entries up to `maxTableSize`.

13.1.3.3 AcceptableMaster

The `AcceptableMaster` type represents a port that can be considered, in the execution of the BMCA, as a candidate for master.

```
struct AcceptableMaster {
    PortIdentity acceptablePortIdentity;
    UInteger8 alternatePriority1;
}
```

The `acceptablePortIdentity` member is the `PortIdentity` of an acceptable master port. The `alternatePriority1` member contains an alternate value for the `priority1` attribute of the acceptable master port (see 13.1.3.4).

13.1.3.4 Acceptable master table feature

The acceptable master table feature shall modify the operation of the BMCA (see 10.3) as follows:

- a) If `acceptableMasterTableEnabled` for a port is `FALSE`, the BMCA operates as described in 10.3 and its subclauses.
- b) If `acceptableMasterTableEnabled` for a port is `TRUE`, then:
 - 1) The function `qualifyAnnounce()` of the `PortAnnounceReceive` state machine (see 10.3.10.2.1) is replaced by the following:

qualifyAnnounce (rcvdAnnouncePtr): qualifies the received `Announce` message pointed to by `rcvdAnnouncePtr` as follows:

- i) if the `Announce` message was sent by the current time-aware system, i.e., if `sourcePortIdentity.clockIdentity` (see 10.5.2.2.8 and 8.5.2) is equal to `thisClock` (see 10.2.3.22), the `Announce` message is not qualified and `FALSE` is returned;
 - ii) if the `stepsRemoved` field is greater than or equal to 255, the `Announce` message is not qualified and `FALSE` is returned;
 - iii) if the `sourcePortIdentity` of the `Announce` message is not equal to the `sourcePortIdentity` of one of the entries of the `acceptableMasterTable`, `FALSE` is returned;
 - iv) if a path trace TLV is present and one of the elements of the `pathSequence` array field of the path trace TLV is equal to `thisClock` (i.e., the `clockIdentity` of the current time-aware system, see 10.2.3.22), the `Announce` message is not qualified and `FALSE` is returned; otherwise, the `Announce` message is qualified and `TRUE` is returned. If a path trace TLV is present and the `portRole` of the port is `SlavePort`, the `pathSequence` array field of the TLV is copied to the global array `pathTrace`, and `thisClock` is appended to `pathTrace` (i.e., is added to the end of the array).
- 2) If the `alternatePriority1` member of the `AcceptableMaster` array element that corresponds to the `sourcePortIdentity` of a received `Announce` message is 0, the `alternatePriority1` member has no effect on the operation of BMCA.
 - 3) If the `alternatePriority1` member of the `AcceptableMaster` array element that corresponds to the `sourcePortIdentity` of a received `Announce` message is greater than 0, the value of the `grandmasterPriority1` field of the `Announce` message is replaced by the value of `alternatePriority1` of this `AcceptableMaster` array element for use in the invocation of BMCA.

13.1.3.5 Default configuration of acceptable master table feature

The default configuration of the acceptable master table feature for a time-aware system that is attached to an IEEE 802.3 EPON link shall be as follows:

- a) If the time-aware system does not contain an ONU port, the default acceptableMasterTable is empty, i.e., the member actualTableSize is 0 and there are no AcceptableMaster array entries. The variable acceptableMasterTableEnabled for each port is set to FALSE.
- b) If the time-aware system contains an ONU port, the default acceptableMasterTable contains one element in the AcceptableMaster array. The member actualTableSize is 1. The acceptablePortIdentity of that element is set equal to the portIdentity of the OLT port that the ONU port is attached to, and alternatePriority1 set equal to 244. The variable acceptableMasterTableEnabled for each port is set to TRUE.

NOTE—These default settings ensure that, with the default priority1 values of 8.6.2.1, Table 8-2, used for all time-aware systems, the time-aware system that contains the ONU port will consider Announce messages only from the OLT that the ONU port is attached to when invoking the BMCA. The alternatePriority1 value of 244 ensures that the OLT will be considered better than the ONU in the sense of the BMCA, which will cause the OLT port role to be set to MasterPort and the ONU port role to be set to SlavePort. All other ports of this time-aware system that are not disabled and for which asCapable is TRUE will have port roles of either MasterPort or PassivePort. If all time-aware systems downstream from the ONU have priority1 greater than 244, then the port at the other end of each link attached to each non-ONU port that is not disabled and for which asCapable is TRUE will have port roles of either SlavePort or PassivePort; in this case, the downstream network portions will get their timing through the EPON. However, if a downstream time-aware system has priority1 less than 244, or priority1 equal to 244 and is better than the grandmaster information contained in the Announce message received by the ONU based on other attributes, then the portion of the network that is downstream of the ONU and includes that better time-aware system will get its timing from that better downstream time-aware system. In this case, the endpoints of the link of that network portion attached to the time-aware system that contains the ONU will both have port roles of MasterPort, and the ports at each end of the link will send Announce messages. However, the Announce messages sent by the downstream time-aware system will be ignored by the time-aware system that contains the ONU because the sourcePortIdentity of those Announce messages will not be contained in the acceptableMasterTable. The Announce messages sent by the time-aware system that contains the ONU will be used in the invocation of the BMCA at the downstream node; however, those Announce messages will not reflect the best master because one of the downstream time-aware systems is better.

13.1.4 Time synchronization in EPON

Transmission in the EPON downstream direction (from OLT to ONUs) utilizes time division multiplexing (TDM). In the upstream direction (from ONUs to OLT), time division multiple access (TDMA) is employed. Due to the frame queuing in TDMA, the downstream delay is different from the upstream delay. Asymmetric delay also occurs in the EPON physical layer due to upstream and downstream transmission using different wavelengths. The index of refraction is frequency dependent, which results in the upstream and downstream delays being asymmetric. The accurate time synchronization across the EPON links is operated as follows. It is assumed that the clock master (the OLT) has an accurate synchronized time. The clock master informs the clock slave (the ONU) what the accurate synchronized time will be when the counter of the clock slave reaches a certain value. The information transfer can be accomplished using the organization-specific slow protocol (OSSP) message (see Clause 57 of IEEE Std 802.3-2008).

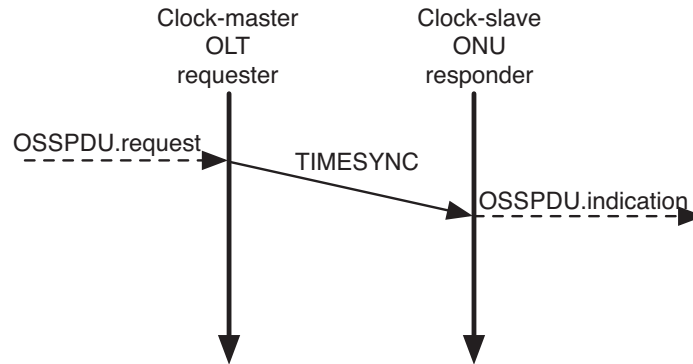

Figure 13-1—IEEE 802.3 EPON time-synchronization interfaces

The following reference process, illustrated schematically in Figure 13-1, will result in the clock slave of an ONU being synchronized to the clock master of the OLT:

- a) The clock master selects a value X of the local MPCP counter that is used as the timing reference. Any value may be chosen, provided it is relative to the current epoch of the MPCP counter.
- b) The clock master calculates the $ToD_{X,i}$ based on $ToD_{X,o}$ using Equation (13-1).

$$ToD_{X,i} = ToD_{X,o} + RTT_i \cdot \frac{ndown}{(nup + ndown)} \cdot rateRatio \quad (13-1)$$

where $ToD_{X,i}$ is the synchronized time when the MPCP counter at the clock slave i reaches a value equal to the timestamp X minus the *onuLatencyFactor*; $ToD_{X,o}$ is the synchronized time when the MPCP counter at the clock master reaches a value equal to the timestamp X plus the *oltLatencyFactor*; RTT_i is the round-trip time measured by the clock master for clock slave i , i.e., ONU i ; nup is the effective refraction index of the light propagating in the upstream channel; $ndown$ is the effective refraction index of the light propagating in the downstream channel; and $rateRatio$ is the $rateRatio$ member of the most recently received $MDSyncSend$ structure. The *onuLatencyFactor* and *oltLatencyFactor* are given in Equation (13-2) and Equation (13-3), respectively. The impact of the worst-case variation in the transmission wavelength for the clock master and clock slave transmitters is examined in VII of ITU-T G.984.3, Amendment 2.

$$onuLatencyFactor = onuIngressLatency - \frac{ndown}{(nup + ndown)} \cdot rateRatio \quad (13-2)$$

$$oltLatencyFactor = oltEgressLatency - \frac{ndown}{(nup + ndown)} \cdot rateRatio \quad (13-3)$$

- c) The clock master sends the pair of values $(X, ToD_{X,i})$ to clock slave i via the downstream TIMESYNC message.

NOTE—After the clock slave receives the downstream TIMESYNC message, it can compute the synchronized time, ToD , when the value of the local MPCP counter is equal to S ; ToD is given by the following equation:

$$ToD = ToD_{X,i} + [(S - X) \bmod (2^{32})](16 \text{ ns}) \cdot \text{rateRatio}$$

where $(A) \bmod (B)$ is A modulo B .

The OSSP message is a general message (see 3.8), analogous to Follow_Up. Note that the preceding synchronized time values correspond to timestamps that are referenced to the MAC control sublayer. Both the clock master and clock slave are responsible for compensating their processing delays (e.g., the ingressLatency and egressLatency, as described in 8.4.3). RTT_i is measured using MPCPDU timestamps, inserted into the frame structure as specified by 64.2.1.1 of IEEE Std 802.3-2008 and 77.2.1.1 of IEEE Std 802.3av-2009.

13.2 Message attributes

13.2.1 Message class

The TIMESYNC message is a general message (see 3.8 and 8.4.2.2). It is transmitted in the downstream direction, from OLT to ONU.

13.3 Message format

13.3.1 TIMESYNC message

13.3.1.1 General TIMESYNC message specifications

The fields of the body of the TIMESYNC message shall be as specified in Table 13-1 and 13.3.1.2 and its subclauses.

13.3.1.2 TIMESYNC message field specifications

13.3.1.2.1 Destination address (Octet6)

The destination address field is equal to 0x0180C2000002 (see 57A.3 of IEEE Std 802.3-2008).

13.3.1.2.2 Source address (Octet6)

The source address field is the individual MAC address associated with the port through which the TIMESYNC message is transmitted (see 57B.1.1 of IEEE Std 802.3-2008).

13.3.1.2.3 Length/Type (Octet2)

The value of this field is equal to 0x8809 (see 57A.4 of IEEE Std 802.3-2008).

13.3.1.2.4 Subtype (Octet)

The value of this field is equal to 0x0A (see 57A.4 of IEEE Std 802.3-2008).

Table 13-1—TIMESYNC message fields

Bits								Octets	Offset
8	7	6	5	4	3	2	1		
Destination Address								6	0
Source Address								6	6
Length/Type								2	12
Subtype								1	14
Organizationally Unique Identifier								3	15
Message Identifier								2	18
X								4	20
$ToD_{X,i}$								10	24
sourcePortIdentity								10	34
logMessageInterval								1	44
rateRatio								8	45
gmTimeBaseIndicator								2	53
lastGmPhaseChange								12	55
scaledLastGmFreqChange								4	67
FCS								4	71

13.3.1.2.5 Organizationally Unique Identifier (Octet3)

This field contains the Organizationally Unique Identifier (OUI) to identify the Organization-Specific Data. The OUI assigned to IEEE 802.1 is 0x0080C2.

13.3.1.2.6 Message identifier (Octet2)

This field is the TIMESYNC message identifier. The value of this field is 1.

13.3.1.2.7 X (UInteger32)

The X field is the selected timestamp that will be used as the timing reference as specified in 13.1.4.

13.3.1.2.8 $ToD_{X,i}$ (Timestamp)

$ToD_{X,i}$ is the synchronized time when the MPCP counter at the clock slave i reaches a value equal to X minus the *onuLatencyFactor* (see 13.1.4). X is carried in the respective TIMESYNC message. Synchronization of the MPCP clock is described in detail in 64.2.1.1 in IEEE Std 802.3-2008 for 1G-EPON and in 77.2.1.1 in IEEE Std 802.3av-2009 for 10G-EPON.

NOTE—Any subnanosecond portion of synchronized time (in this case, time of day), normally transported in a correction field (see 10.2.2.1.2, 10.2.2.2.2, and 10.2.2.3.4), is not transported over EPON.

13.3.1.2.9 sourcePortIdentity (PortIdentity)

This field is specified as the sourcePortIdentity member of the MDSyncSend structure most recently received from the PortSync entity of the OLT (see 10.2.2.1.3).

13.3.1.2.10 logMessageInterval (Integer8)

This field is specified as the logMessageInterval member of the MDSyncSend structure most recently received from the PortSync entity of the OLT (see 10.2.2.1.4). It is the value of the currentLogSyncInterval for this port (see 10.6.2.3).

13.3.1.2.11 rateRatio (Double)

This field is specified as the rateRatio member of the MDSyncSend structure most recently received from the PortSync entity of the OLT (see 10.2.2.1.7).

13.3.1.2.12 gmTimeBaseIndicator (UInteger16)

This field is specified as the gmTimeBaseIndicator member of the MDSyncSend structure most recently received from the PortSync entity of the OLT (see 10.2.2.1.8).

13.3.1.2.13 lastGmPhaseChange (ScaledNs)

This field is specified as the lastGmPhaseChange member of the MDSyncSend structure most recently received from the PortSync entity of the OLT (see 10.2.2.1.9).

13.3.1.2.14 scaledLastGmFreqChange (Integer32)

The value of scaledLastGmFreqChange is the fractional frequency offset of the current grandmaster relative to the previous grandmaster, at the time that the current grandmaster became grandmaster, or relative to itself prior to the last change in gmTimeBaseIndicator, multiplied by 2^{41} and truncated to the next smaller signed integer. The value is obtained by multiplying the lastGmFreqChange member of MDSyncSend (see 10.2.2.1) whose receipt causes the MD entity to send the TIMESYNC message by 2^{41} , and truncating to the next smaller signed integer.

NOTE—The above scaling allows the representation of fractional frequency offsets in the range $[-(2^{-10} - 2^{-41}), 2^{-10} - 2^{-41}]$, with granularity of 2^{-41} . This range is approximately $[-9.766 \times 10^{-4}, 9.766 \times 10^{-4}]$.

13.3.1.2.15 FCS (Octet4)

This field is the Frame Check Sequence (see 57B.1.1 of IEEE 802.3-2008).

13.4 Determination of asCapable

The default value of the per-port global variable asCapable shall be set to TRUE.

13.5 Layering for IEEE 802.3 EPON links

The MD entity is media-dependent and is responsible for translating the media-independent layer to media-dependent PDUs or primitives as necessary for communicating synchronized time over the EPON link from the OLT to a single ONU. This implies that if one OLT port is associated with multiple ONUs, it will require one IEEE 802.1AS PortSync entity and one MD entity per associated ONU. The OSSPDU primitives are used to communicate synchronized time information. Figure 13-2 illustrates how the MD entity interacts with the OSSP sublayer.

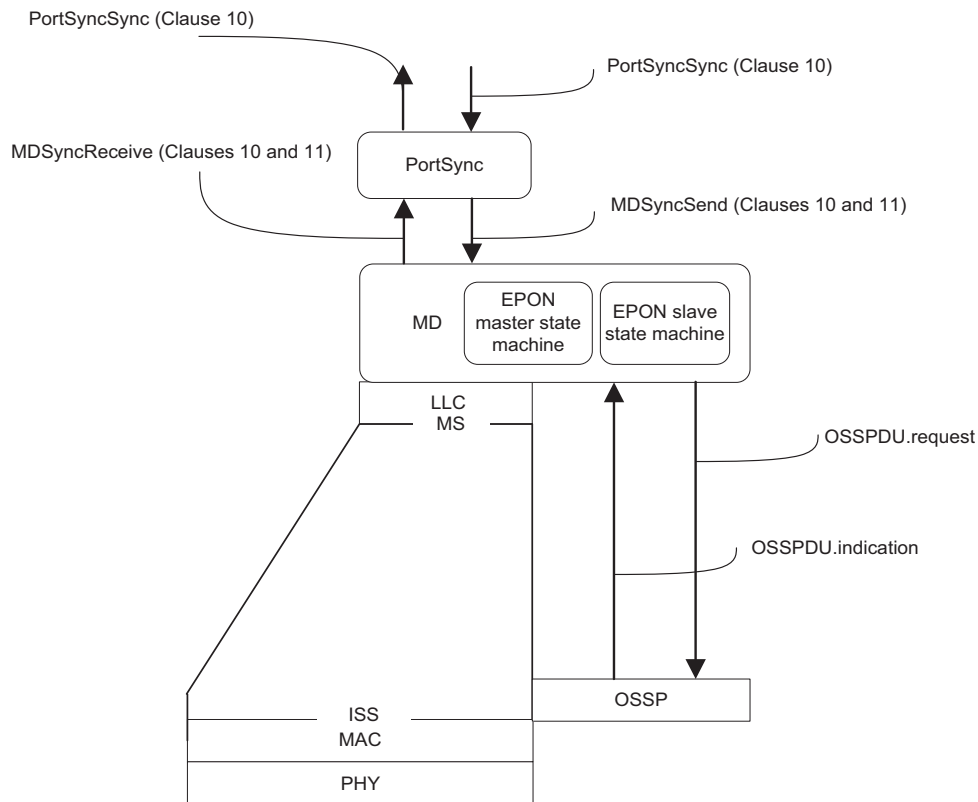

Figure 13-2—IEEE 802.3 EPON interface model

13.6 Service interface definitions

13.6.1 OOSPDU.request

13.6.1.1 General

This service interface primitive is generated periodically by the MD entity of the clock master every sync interval (see 10.6.2.1). It triggers transmission of a TIMESYNC message from the clock master to the clock slave. The values of the parameters of the primitive are sent to the clock slave via the TIMESYNC message.

13.6.1.2 OOSPDU.request parameters

```
OOSPDU.request {
    X
    ToDX,i
    sourcePortIdentity
    logMessageInterval
    rateRatio
    gmTimeBaseIndicator
    lastGmPhaseChange
    scaledLastGmFreqChange
}
```

The parameter definitions are as follows:

13.6.1.3 X (Integer32)

The X field is the selected timestamp that will be used as the timing reference as specified in 13.1.4.

13.6.1.4 $ToD_{X,i}$ (Timestamp)

$ToD_{X,i}$ is the synchronized time when the MPCP counter at the clock slave i reaches a value equal to X minus the *onuLatencyFactor* (see 13.1.4). X is carried in the respective TIMESYNC message. Synchronization of the MPCP clock is described in detail in 64.2.1.1 in IEEE Std 802.3-2008 for 1G-EPON and in 77.2.1.1 in IEEE Std 802.3av-2009 for 10G-EPON.

13.6.1.5 sourcePortIdentity (PortIdentity)

This parameter identifies the sourcePortIdentity value for this port (see 13.3.1.2.9).

13.6.1.5.1 logMessageInterval (Integer8)

This parameter identifies the currentLogSyncInterval value for this port (see 13.3.1.2.10).

13.6.1.5.2 rateRatio (Double)

This parameter identifies the rateRatio value for this port (see 13.3.1.2.11).

13.6.1.5.3 gmTimeBaseIndicator (UInteger16)

This parameter identifies the gmTimeBaseIndicator value for this port (see 13.3.1.2.12).

13.6.1.5.4 lastGmPhaseChange (ScaledNs)

This parameter identifies the lastGmPhaseChange value for this port (see 13.3.1.2.13).

13.6.1.5.5 scaledLastGmFreqChange (Integer32)

This parameter identifies the scaledLastGmFreqChange value for this port (see 13.3.1.2.14).

13.6.1.6 When generated

This primitive is generated by the clock master every $2^{\text{currentLogSyncInterval}}$ seconds when it is in the MASTER state, as the first phase of synchronized time information transfer.

13.6.1.7 Effect of receipt

Upon receipt of this primitive, a TIMESYNC message is enqueued for transmission.

NOTE—Arrival of the TIMESYNC message at the ONU after the selected time X does not impede proper operation of the synchronization mechanism defined in this clause.

13.6.2 OSSPDU.indication

13.6.2.1 General

This service interface primitive is generated on receipt of a TIMESYNC message by the responder, and provides the values contained in the corresponding OSSPDU.request primitive to the clock slave.

13.6.2.2 OSSPDU.indication parameters

```
OSSPDU.indication {  
    X  
    ToDX,i  
    sourcePortIdentity  
    logMessageInterval  
    rateRatio  
    gmTimeBaseIndicator  
    lastGmPhaseChange  
    scaledLastGmFreqChange  
}
```

The parameters of the OSSPDU.indication are set equal to the corresponding fields of the most recently received TIMESYNC message. Their definitions are given in 13.6.1.3 through 13.6.1.5.5, respectively.

13.6.2.3 When generated

This primitive is generated by the receipt of a TIMESYNC message during the phase of synchronized time information transfer.

13.6.2.4 Effect of receipt

Upon receipt, the OSSPDU.indication parameters are used by the MD entity to compute the parameters of the MDSyncReceive structure that will be transmitted to the PortSync entity of this port.

13.7 MD entity global variables

13.7.1 RTT_i : is used only by the OLT MD entity. RTT_i is the RTT between the clock master and clock slave. The data type for RTT_i is UInteger32.

NOTE—RTT is measured and updated by the MPCP using the mechanism specified in IEEE Std 802.3-2008 and IEEE Std 802.3av-2009, and stored in RTT_i when measured and updated. RTT_i is not used by the ONU, and is set to zero in an ONU MD entity.

13.8 State machines

13.8.1 Requester state machine

13.8.1.1 Function

This state machine generates and consumes primitives, at the requester, used to provide accurate synchronized time across EPON links to the responder.

13.8.1.2 State machine variables

The following variables are used in the state diagram of 13.8.1.4:

13.8.1.2.1 ndown: the effective index of the light propagating in the downstream channel. The data type for ndown is Double.

13.8.1.2.2 nup: the effective index of the light propagating in the upstream channel. The data type for ndown is Double.

13.8.1.2.3 rcvdMDSync: a Boolean variable that notifies the current state machine when an MDSyncSend structure is received. This variable is reset by the current state machine.

13.8.1.2.4 rcvdMDSyncPtr: a pointer to the received MDSyncSend structure.

13.8.1.2.5 registered: a Boolean variable that indicates an ONU has registered to EPON.

13.8.1.2.6 $ToD_{X,i}$: the synchronized time when the MPCP counter at the clock slave i reaches a value equal to X (see 13.8.1.2.7) minus the *onuLatencyFactor* (see 13.1.4). The data type for $ToD_{X,i}$ is Timestamp.

13.8.1.2.7 $ToD_{X,o}$: the synchronized time when the MPCP counter at the clock master reaches a value equal to X (see 13.8.1.2.7) plus the *oltLatencyFactor* (see 13.1.4). The data type for $ToD_{X,o}$ is Timestamp.

13.8.1.2.8 X : the value of the timestamp [see 13.1.4a)] that is selected as the reference time. The data type for X is UInteger32.

13.8.1.3 State machine functions

The following function is used in the state diagram of 13.8.1.4:

- 13.8.1.3.1 setToDXo():** computes the state machine variable $ToD_{X,o}$ (see 13.8.1.2.7) as the sum of:
- The preciseOriginTimestamp member of the most recently received MDSyncSend structure,
 - The followUpCorrectionField of the most recently received MDSyncSend structure, and
 - The quantity

$$\text{rateRatio} \times (X \times (16 \text{ ns}) - \text{upstreamTxTime}) \tag{13-4}$$

where rateRatio and upstreamTxTime are the rateRatio and upstreamTxTime members, respectively, of the most recently received MDSyncSend structure, and X is defined in 13.8.1.2.8 (see 13.8.1.2.7).

13.8.1.4 State diagram

The requester state machine shall implement the function specified by the state diagram in Figure 13-3, the local variables specified in 13.8.1.2, the service interface primitives specified in 13.6, the structure specified in 10.2.2.1, the message specified in 13.3, and the relevant global variables specified in 10.2.4 and 13.7. The state machine receives an MDSyncSend structure from the PortSyncSyncSend state machine of the PortSync entity of this port and transmits an OSSPDU.request primitive to cause a TIMESYNC message to be sent to the responder (ONU).

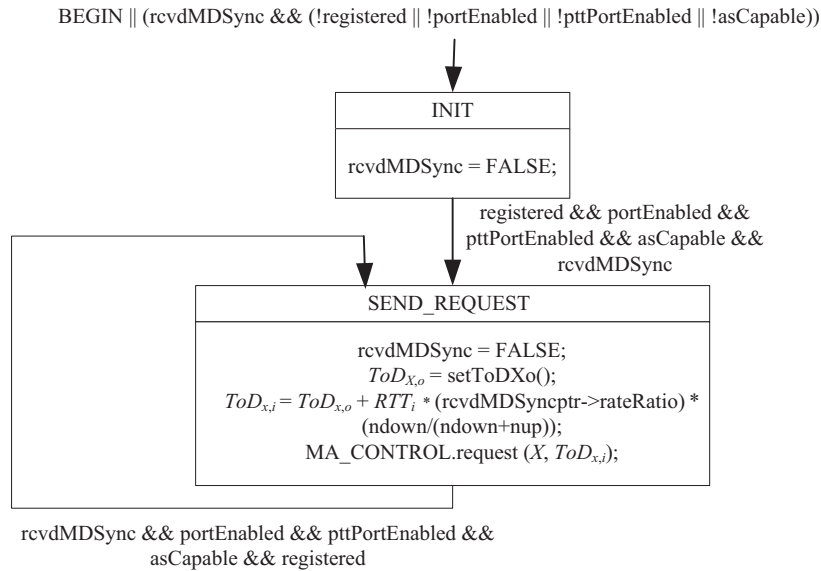

Figure 13-3—State machine for IEEE 802.3 EPON requester

13.8.2 Responder state machine

13.8.2.1 Function

This state machine responds to EPON-specific primitives generated by receipt of a TIMESYNC message from the requester.

13.8.2.2 State machine variables

The following variables are used in the state diagram of 13.8.1.4:

13.8.2.2.1 rcvdOSSPDUind: a Boolean variable that notifies the responder state machine when a TIMESYNC message is received and the OSSPDU.indication primitive is generated.

13.8.2.2.2 txMDSyncReceivePtr: a pointer to a structure whose members contain the values of the parameters of an MDSyncReceive structure to be transmitted.

13.8.2.2.3 rcvdOSSPDUptr: a pointer to a structure whose members contain the values of the parameters of the OSSPDU.indication primitive whose receipt is indicated by rcvdOSSPDUind (see 13.8.2.2.1).

13.8.2.3 State machine functions

The following functions are used in the state diagram of 13.8.2.4:

13.8.2.3.1 setMDSyncReceive(): creates an MDSyncReceive structure (see 10.2.2.2) using members of the structure pointed to by rcvdOSSPDUptr (see 13.8.2.2.3), and returns a pointer to this structure. The members of this structure are set as follows:

- a) followUpCorrectionField is set equal to 0,

- b) sourcePortIdentity is set equal to an 8-byte clockIdentity plus a 2-byte portNumber. The 8-byte clockIdentity is generated by mapping the 6 byte Source Address (see 13.3.1.2.2) of the most recently received TIMESYNC message, which is an EUI-48, to an EUI-64 format (see 8.5.2.2.1). The 2-byte portNumber is set equal to 1,
- c) logMessageInterval is set equal to the logMessageInterval of the most recently received TIMESYNC message (see 13.3.1.2.10),
- d) preciseOriginTimestamp is set equal to the $ToD_{X,i}$ field of the most recently received TIMESYNC message (see 13.3.1.2.8),
- e) rateRatio is set to the rateRatio of the most recently received TIMESYNC message (see 13.3.1.2.11),
- f) upstreamTxTime is set equal to X multiplied by 16 ns, where X is the value of the X field of the most recently received TIMESYNC message (see 13.3.1.2.7),
- g) gmTimeBaseIndicator is set equal to the gmTimeBaseIndicator of the most recently received TIMESYNC message (see 13.3.1.2.12),
- h) lastGmPhaseChange is set equal to the lastGmPhaseChange of the most recently received TIMESYNC message (see 13.3.1.2.13), and
- i) lastGmFreqChange is set equal to the scaledLastGmFreqChange of the most recently received TIMESYNC message (see 13.3.1.2.14), divided by 2^{41} .

13.8.2.3.2 txMDSyncReceive (txMDSyncReceivePtr): transmits an MDSyncReceive structure to the PortSyncSyncReceive state machine of the PortSync entity of this port.

13.8.2.4 State diagram

The responder state machine shall implement the function specified by the state diagram in Figure 13-4, the local variables specified in 13.8.2.2, the functions specified in 13.8.2.3, the service interface primitives specified in 13.6, the structure specified in 10.2.2.2, the message specified in 13.3, and the relevant global variables specified in 10.2.4 and 13.7. The state machine receives an OSSPDU.indication primitive in response to its having received a TIMESYNC message from the requester (OLT), and transmits an MDSyncReceive structure to the PortSync entity of this port.

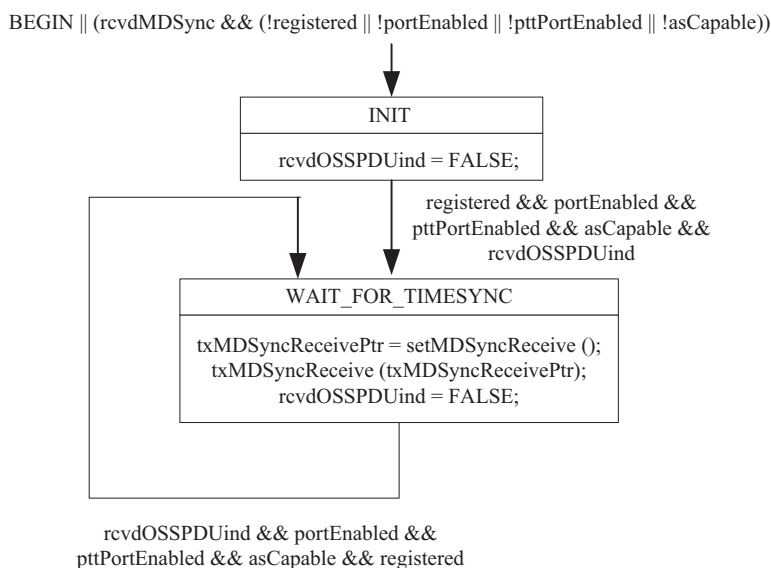

Figure 13-4—State machine for IEEE 802.3 EPON responder

13.9 Message transmission intervals

13.9.1 General interval specification.

The mean time interval between successive TIMESYNC messages shall be as specified in 10.6.2.1, 10.6.2.3, and 13.9.2.

13.9.2 TIMESYNC message transmission interval default value

The default value of `initialLogSyncInterval` (see 10.6.2.4) is `-3`. Every port supports the value `127`; the port does not send TIMESYNC messages when `currentLogSyncInterval` has this value. A port may support other values, except for the reserved values `-128` through `-125`, inclusive, and `124` through `126`, inclusive.

Processing of the message interval request TLV carried in a Signaling message (see 10.5.4) shall be supported, as specified by the `LinkDelaySyncIntervalSetting` state machine of 11.2.17 (see Figure 11-10), except that: the `LinkDelayInterval` (which is not relevant to IEEE 802.3 EPON ports) is set to `128` by the sender of the Signaling message, the `LinkDelayInterval` is ignored by the receiver, and unsupported values of `timeSyncInterval` are ignored by the receiver.

14. Timing and synchronization management

14.1 General

This clause defines the set of managed objects, and their functionality, that allow administrative configuration of clock parameters and timing and synchronization protocols.

The objects that comprise this management resource are as follows:

- a) The Default Parameter Data Set (Table 14-1), which represents the native capabilities of a time-aware system, a Bridge or an end station;
- b) The Current Parameter Data Set (Table 14-2), which represents the position of a local system and other information, relative to the grandmaster;
- c) The Parent Parameter Data Set (Table 14-3), which represents capabilities of the up-stream system, toward the grandmaster, as measured at a local system;
- d) The Time Properties Parameter Data Set (Table 14-4), which represents capabilities of the grandmaster, as measured at a local system;
- e) The Port Parameter Data Set (Table 14-6), which represents time-aware capabilities at a given Bridge or end station port;
- f) The Port Parameter Statistics (Table 14-8), which represent statistics and counters associated with time-aware capabilities at a given Bridge or end station port; and
- g) The Acceptable Master Table Parameter Data Set (Table 14-8), which represents the acceptable master table used when an EPON port is present in a time-aware system.

NOTE—The Port Parameter Data Set and the Port Parameter Statistics correspond to a logical port; a Bridge or end station physical port may contain one or more logical ports (see 8.5.1). For example, a bridge physical port can be connected to a full-duplex, point-to-point link that contains one logical port. As another example, a bridge physical port can be connected to a CSN link that contains more than one logical port.

14.2 Default Parameter Data Set

The Default Parameter Data Set represents the native capabilities of a time-aware system, a Bridge, or an end station.

14.2.1 clockIdentity

The value is the clockIdentity, see 8.5.2.2, of the local clock.

14.2.2 numberPorts

The value is the number of ports of the time-aware system, see 8.6.2.8. For an end station the value is 1.

14.2.3 clockClass

The value is the clockClass of the time-aware system, which implements the clockClass specifications of 8.6.2.2.

14.2.4 clockAccuracy

The value is the clockAccuracy of the time-aware system, which implements the clockAccuracy specifications of 8.6.2.3.

14.2.5 offsetScaledLogVariance

The value is the `offsetScaledLogVariance` of the time-aware system, which implements the `offsetScaledLogVariance` specifications of 8.6.2.4.

14.2.6 priority1

The value is the `priority1` attribute of the time-aware system, see 8.6.2.1.

14.2.7 priority2

The value is the `priority2` attribute of the time-aware system, see 8.6.2.5.

14.2.8 gmCapable

The value is `TRUE` if the time-aware system is capable of being a grandmaster, and `FALSE` if the time-aware system is not capable of being a grandmaster.

14.2.9 currentUtcOffset

The value is the offset between TAI and UTC, relative to the `ClockMaster` entity of this time-aware system. It is equal to the global variable `sysCurrentUtcOffset` (see 10.3.8.16). The value is in units of seconds.

The default value is selected as follows:

- a) The value is the value obtained from a primary reference if the value is known at the time of initialization, else
- b) The value is the current number of leap seconds, see 8.2.3, when the time-aware system is designed.

14.2.10 currentUtcOffsetValid

The value is `TRUE` if the `currentUtcOffset`, relative to the `ClockMaster` entity of this time-aware system, is known to be correct. It is equal to the global variable `sysCurrentUtcOffsetValid` (see 10.3.8.13).

The default value is `TRUE` if the value of `currentUtcOffset` is known to be correct, otherwise it is set to `FALSE`.

14.2.11 leap59

A `TRUE` value indicates that the last minute of the current UTC day, relative to the `ClockMaster` entity of this time-aware system, will contain 59 s. It is equal to the global variable `sysLeap59` (see 10.3.8.12).

The value is selected as follows:

- a) The value is obtained from a primary reference if known at the time of initialization, else
- b) The value is set to `FALSE`.

14.2.12 leap61

A `TRUE` value indicates that the last minute of the current UTC day, relative to the `ClockMaster` entity of this time-aware system, will contain 61 s. It is equal to the global variable `sysLeap59` (see 10.3.8.11).

The value is selected as follows:

- a) The value is obtained from a primary reference if known at the time of initialization, else
- b) The value is set to FALSE.

14.2.13 timeTraceable

The value is set to TRUE if the timescale and the value of `currentUtcOffset`, relative to the `ClockMaster` entity of this time-aware system, are traceable to a primary reference standard; otherwise the value is set to FALSE. It is equal to the global variable `sysTimeTraceable` (see 10.3.8.14).

The value is selected as follows:

- a) If the time and the value of `currentUtcOffset` are traceable to a primary reference standard at the time of initialization, the value is set to TRUE, else
- b) The value is set to FALSE.

14.2.14 frequencyTraceable

The value is set to TRUE if the frequency determining the timescale of the `ClockMaster` Entity of this time-aware system is traceable to a primary standard; otherwise the value is set to FALSE. It is equal to the global variable `sysFrequencyTraceable` (see 10.3.8.15).

The value is selected as follows:

- a) If the frequency is traceable to a primary reference standard at the time of initialization the value is set to TRUE, else
- b) The value is set to FALSE.

14.2.15 timeSource

The value is the source of time used by the grandmaster clock (see 8.6.2.7).

14.2.16 Default Parameter Data Set Table

There is one Default Parameter Table per time-aware system, as detailed in Table 14-1.

14.3 Current Parameter Data Set

The Current Parameter Data Set represents the position of a local system and other information, relative to the grandmaster.

14.3.1 stepsRemoved

The value is the number of gPTP communication paths traversed between the local clock and the grandmaster clock, as specified in 10.3.3.

The default value is 0.

NOTE—For example, `stepsRemoved` for a slave clock on the same PTP communication path as the grandmaster clock will have a value of 1, indicating that a single path was traversed.

Table 14-1—Default Parameter Data Set Table

Name	Data type	Operations supported ^a	Conformance ^b	References
clockIdentity	ClockIdentity	R	T	14.2.1
numberPorts	Integer8	R	T	14.2.2
clockClass	Enumeration8	R	T	14.2.3 IEEE Std 1588-2008, 7.6.2.4
clockAccuracy	Enumeration8	R	T	14.2.4 IEEE Std 1588-2008, 7.6.2.5
offsetScaledLogVariance	Integer16	R	T	14.2.5
priority1	UInteger8	RW	T	14.2.6
priority2	UInteger8	RW	T	14.2.7
gmCapable	Boolean	R	T	14.2.8
currentUtcOffset	Integer16	RW	T	14.2.9
currentUtcOffsetValid	Boolean	RW	T	14.2.10
leap59	Boolean	RW	T	14.2.11
leap61	Boolean	RW	T	14.2.12
timeTraceable	Boolean	R	T	14.2.13
frequencyTraceable	Boolean	R	T	14.2.14
timeSource	Enumeration8	R	T	14.2.15 and Table 8-3

^aR = Read only access; RW = Read/write access.

^bT= Required for time-aware port.

14.3.2 offsetFromMaster

The value is an implementation-specific representation of the current value of the time difference between a slave and the grandmaster, as computed by the slave, and as specified in 10.2.9. It is recommended that the data type be scaledNs. The default value is implementation specific.

14.3.3 lastGmPhaseChange

The value (see 10.2.3.16) is the phase change that occurred on the most recent change in either grandmaster or gmTimeBaseIndicator (see 9.2.2.2).

14.3.4 lastGmFreqChange

The value (see 10.2.3.17) is the frequency change that occurred on the most recent change in either grandmaster or gmTimeBaseIndicator (see 9.2.2.2).

14.3.5 gmTimebaseIndicator

The value is the value of timeBaseIndicator of the current grandmaster (see 9.2.2.2 and 9.6.2.2).

14.3.6 gmChangeCount

This statistics counter tracks the number of times the grandmaster has changed in a gPTP domain. This counter increments when the PortAnnounceInformation state machine enters the SUPERIOR_MASTER_PORT state or the INFERIOR_MASTER_OR_OTHER_PORT state (see 10.3.11 and Figure 10-13).

14.3.7 timeOfLastGmChangeEvent

This timestamp denotes the system time when the most recent grandmaster change occurred in a gPTP domain. This timestamp is updated when the PortAnnounceInformation state machine enters the SUPERIOR_MASTER_PORT state or the INFERIOR_MASTER_OR_OTHER_PORT state (see 10.3.11 and Figure 10-13).

14.3.8 timeOfLastGmPhaseChangeEvent

This timestamp denotes the system time when the most recent change in grandmaster phase occurred, due to a change of either the grandmaster or the grandmaster time base. This timestamp is updated when one of the following occurs:

- a) The PortAnnounceInformation state machine enters the SUPERIOR_MASTER_PORT state or the INFERIOR_MASTER_OR_OTHER_PORT state (see 10.3.11 and Figure 10-13), or
- b) The gmTimebaseIndicator managed object (see 14.3.5) changes and the lastGmPhaseChange field of the most recently received Follow_Up information TLV is nonzero.

14.3.9 timeOfLastGmFreqChangeEvent

This timestamp denotes the system time when the most recent change in grandmaster frequency occurred, due to a change of either the grandmaster or the grandmaster time base. This timestamp is updated when one of the following occurs:

- a) The PortAnnounceInformation state machine enters the SUPERIOR_MASTER_PORT state or the INFERIOR_MASTER_OR_OTHER_PORT state (see 10.3.11 and Figure 10-13), or
- b) The gmTimebaseIndicator managed object (see 14.3.5) changes and the lastGmFreqChange field of the most recently received Follow_Up information TLV is nonzero.

14.3.10 Current Parameter Data Set Table

There is one Current Parameter Data Set Table per time-aware system, as detailed in Table 14-2.

Table 14-2—Current Parameter Data Set Table

Name	Data type	Operations supported ^a	Conformance ^b	References
stepsRemoved	Integer16	R	T	14.3.1
offsetFromMaster	ScaledNs (recommended)	R	T	14.3.2
lastGmPhaseChange	ScaledNs	R	T	14.3.3
lastGmFreqChange	Double	R	T	14.3.4
gmTimebaseIndicator	UInteger16	R	T	14.3.5
gmChangeCount	UInteger32	R	T	14.3.6
timeOfLastGmChangeEvent	UInteger32 (0.01 s 32-bit system time)	R	T	14.3.7
timeOfLastGmPhaseChangeEvent	UInteger32 (0.01 s 32-bit system time)	R	T	14.3.8
timeOfLastGmFreqChangeEvent	UInteger32 (0.01 s 32-bit system time)	R	T	14.3.9

^aR = Read only access; RW = Read/write access.

^bT= Required for time-aware port.

14.4 Parent Parameter Data Set

The Parent Parameter Data Set represents capabilities of the upstream system, toward the grandmaster, as measured at a local system.

14.4.1 parentPortIdentity

If this time-aware system is the grandmaster, the value is a portIdentity whose clockIdentity is the clockIdentity of this time-aware system, and whose portNumber is 0.

If this time-aware system is not the grandmaster, the value is the portIdentity of the MasterPort (see Table 10-4) of the gPTP communication path attached to the single slave port of this time-aware system.

The default value is a portIdentity for which:

- a) The clockIdentity member is the value of the clockIdentity member of the default data set, and
- b) The portNumber member is 0.

14.4.2 cumulativeRateRatio

The value is an estimate of the ratio of the frequency of the grandmaster to the frequency of the LocalClock entity of this time-aware system. cumulativeRateRatio is expressed as the fractional frequency offset multiplied by 2^{41} , i.e., the quantity $(\text{rateRatio} - 1.0)(2^{41})$, where rateRatio is computed by the PortSyncSyncReceive state machine (see 10.2.7.1.4).

14.4.3 grandmasterIdentity

The value is the clockIdentity attribute, see 8.5.2.2, of the grandmaster clock.

The default value is the clockIdentity member of the Default Parameter Data Set (14.2.1).

14.4.4 grandmasterClockClass

The value is the clockClass, see 8.6.2.2, of the grandmaster clock.

The default value is the clockClass member of the default data set.

14.4.5 grandmasterClockAccuracy

The value is the clockAccuracy, see 8.6.2.3, of the grandmaster clock.

The default value is the clock accuracy member of the default data set.

14.4.6 grandmasterOffsetScaledLogVariance

The value is the offsetScaledLogVariance, see 8.6.2.4, of the grandmaster clock.

The default value is the offsetScaledLogVariance member of the default data set.

14.4.7 grandmasterPriority1

The value is the priority1 attribute, see 8.6.2.1, of the grandmaster clock.

The default value is the priority1 value of the default data set.

14.4.8 grandmasterPriority2

The value is the priority2 attribute, see 8.6.2.5, of the grandmaster clock.

The default value is the priority2 value of the default data set.

14.4.9 ParentParameter Data Set Table

There is one Parent Parameter Data Set Table per time-aware system, as detailed in Table 14-3.

Table 14-3—Parent Parameter Data Set Table

Name	Data type	Operations supported ^a	Conformance ^b	References
parentPortIdentity	PortIdentity (see 6.3.3.7)	R	T	14.4.1
cumulativeRateRatio	Integer32	R	T	14.4.2
grandMasterIdentity	ClockIdentity	R	T	14.4.3
grandmasterClockClass	UInteger8	R	T	14.4.4 IEEE Std 1588-2008, 7.6.2.4
grandmasterClockAccuracy	Enumeration8	R	T	14.4.5 IEEE Std 1588-2008, 7.6.2.5
grandmasterOffsetScaledLogVariance	Integer16	R	T	14.4.6
grandmasterPriority1	UInteger8	R	T	14.4.7
grandmasterPriority2	UInteger8	R	T	14.4.8

^aR = Read only access; RW = Read/write access.

^bT = Required for time-aware port.

14.5 Time Properties Parameter Data Set

The Time Properties Parameter Data Set represents capabilities of the grandmaster, as measured at a local system.

14.5.1 currentUtcOffset

The value is currentUtcOffset for the current grandmaster (see 14.2.9). It is equal to the value of the global variable currentUtcOffset (see 10.3.8.9). The value is in units of seconds.

14.5.2 currentUtcOffsetValid

The value is currentUtcOffsetValid for the current grandmaster (see 14.2.10). It is equal to the global variable currentUtcOffsetValid (see 10.3.8.6).

14.5.3 leap59

The value is leap59 for the current grandmaster (see 14.2.11). It is equal to the global variable leap59 (see 10.3.8.5).

14.5.4 leap61

The value is leap59 for the current grandmaster (see 14.2.12). It is equal to the global variable leap61 (see 10.3.8.4).

14.5.5 timeTraceable

The value is timeTraceable for the current grandmaster (see 14.2.13). It is equal to the global variable timeTraceable (see 10.3.8.7).

14.5.6 frequencyTraceable

The value is frequencyTraceable for the current grandmaster (see 14.2.14). It is equal to the global variable frequencyTraceable (see 10.3.8.8).

14.5.7 timeSource

The value is timeSource for the current grandmaster (see 14.2.15). It is equal to the global variable timeSource (see 10.3.8.10).

14.5.8 Time Properties Parameter Data Set Table

There is one Time Properties Parameter Data Set Table per time-aware system, as detailed in Table 14-4.

Table 14-4—Time Properties Parameter Data Set Table

Name	Data type	Operations supported ^a	Conformance ^b	References
currentUtcOffset	Integer16	R	T	14.5.1
currentUtcOffsetValid	Boolean	R	T	14.5.2
leap59	Boolean	R	T	14.5.3
leap61	Boolean	R	T	14.5.4
timeTraceable	Boolean	R	T	14.5.5
frequencyTraceable	Boolean	R	T	14.5.6
timeSource	Enumeration8	R	T	14.5.7 and Table 8-3

^aR = Read only access; RW = Read/write access.

^bT = Required for time-aware port.

14.6 Port Parameter Data Set

The Port Parameter Data Set represents time-aware port capabilities at a given Bridge or end station.

14.6.1 General

For the single port of a time-aware end station and for each port of a time-aware Bridge, the following Port Parameter Data Set is maintained as the basis for protocol decisions and providing values for message fields. The number of such data sets is the same as the numberPorts value of the Default Parameter Data Set.

14.6.2 portIdentity

The value is the portIdentity attribute of the local port, see 8.5.2.

14.6.3 portRole

The value is the value of the port role of this port (see Table 10-1) and is taken from the enumeration in Table 14-5.

Table 14-5—portRole enumeration

State	Value
DisabledPort	3
MasterPort	6
PassivePort	7
SlavePort	9
	All other values reserved

NOTE—The enumeration values are consistent with IEEE Std 1588-2008, Table 8.

The default value is 3 (DisabledPort).

14.6.4 pttPortEnabled

The value is equal to the value of the Boolean pttPortEnabled (see 10.2.4.12).

14.6.5 isMeasuringDelay

The value is equal to the value of the Boolean isMeasuringDelay (see 11.2.12.5 and E.4.3.2).

14.6.6 asCapable

The value is equal to the value of the Boolean asCapable (see 10.2.4.1).

14.6.7 neighborPropDelay

The value is equal to the value of the per-port global variable neighborPropDelay (see 10.2.4.7). It is an estimate of the current one-way propagation time on the link attached to this port, measured as specified for the respective medium (see 11.2.15, 12.4.2, and E.4). The value is zero for ports attached to IEEE 802.3 EPON links and for the master port of an IEEE 802.11 link, because one-way propagation delay is not measured on the latter and not directly measured on the former. It is recommended that the data type be scaledNs. The default value is zero.

14.6.8 neighborPropDelayThresh

The value is equal to the value of the per-port global variable neighborPropDelayThresh (see 11.2.12.6). It is the propagation time threshold, above which a port is not considered capable of participating in the IEEE 802.1AS protocol.

14.6.9 delayAsymmetry

The value is the asymmetry in the propagation delay on the link attached to this port relative to the grandmaster time base, as defined in 8.3. If propagation delay asymmetry is not modeled, then delayAsymmetry is 0.

14.6.10 neighborRateRatio

The value is an estimate of the ratio of the frequency of the LocalClock entity of the time-aware system at the other end of the link attached to this port, to the frequency of the LocalClock entity of this time-aware system (see 10.2.4.6). neighborRateRatio is expressed as the fractional frequency offset multiplied by 2^{41} , i.e., the quantity $(\text{neighborRateRatio} - 1.0)(2^{41})$.

14.6.11 initialLogAnnounceInterval

The value is the logarithm to base 2 of the announce interval used when (a) the port is initialized, or (b) a message interval request TLV is received with the announceInterval field set to 126 (see 10.6.2.2 and the AnnounceIntervalSetting state machine, 10.3.14).

14.6.12 currentLogAnnounceInterval

The value is the logarithm to the base 2 of the of the current announce interval, see 10.6.2.2.

14.6.13 announceReceiptTimeout

The value is the number of Announce message transmission intervals that a slave port waits without receiving an Announce message, before assuming that the master is no longer transmitting Announce messages and the BMCA needs to be run, if appropriate (see 10.6.3.2).

14.6.14 initialLogSyncInterval

The value is the logarithm to base 2 of the sync interval used when (a) the port is initialized, or (b) a message interval request TLV is received with the timeSyncInterval field set to 126 (see 10.6.2.3, 11.5.2.3, 12.6.2, 13.9.2, and the LinkDelaySyncIntervalSetting state machine, 11.2.17).

14.6.15 currentLogSyncInterval

The value is the logarithm to the base 2 of the current time-synchronization transmission interval, see 10.6.2.3.

14.6.16 syncReceiptTimeout

The value is the number of time-synchronization transmission intervals that a slave port waits without receiving synchronization information, before assuming that the master is no longer transmitting synchronization information and that the BMCA needs to be run, if appropriate (see 10.6.3.1).

14.6.17 syncReceiptTimeoutTimeInterval

The value is equal to the value of the per-port global variable syncReceiptTimeoutTimeInterval (see 10.2.4.2). It is the time interval after which sync receipt timeout occurs if time-synchronization information has not been received during the interval.

14.6.18 initialLogPdelayReqInterval

For full-duplex, IEEE 802.3 media and CSN media that use the peer delay mechanism to measure path delay (see E.4.3.1), the value is the logarithm to base 2 of the Pdelay_Req message transmission interval used when (a) the port is initialized, or (b) a message interval request TLV is received with the linkDelayInterval field set to 126 (see 11.5.2.2 and the LinkDelaySyncIntervalSetting state machine, 11.2.17).

For all other media, the value is 127.

14.6.19 currentLogPdelayReqInterval

For full-duplex, IEEE 802.3 media and CSN media that use the peer delay mechanism to measure path delay (see E.4.3.1), the value is the logarithm to the base 2 of the current Pdelay_Req message transmission interval, see 11.5.2.2.

For all other media, the value is 127.

14.6.20 allowedLostResponses

The value is equal to the value of the per-port global variable allowedLostResponses (see 11.5.3 and 11.2.12.4). It is the number of Pdelay_Req messages for which a valid response is not received, above which a port is considered to not be exchanging peer delay messages with its neighbor.

14.6.21 versionNumber

This value is set to versionPTP as specified in 10.5.2.2.3.

14.6.22 nup

For an OLT port of an IEEE 802.3 EPON link, the value is the effective index of refraction for the EPON upstream wavelength light of the optical path (see 13.1.4 and 13.8.1.2.2). The default value is 1.46770 for 1 Gb/s upstream links, and 1.46773 for 10 Gb/s upstream links.

For all other ports, the value is 0.

14.6.23 ndown

For an OLT port of an IEEE 802.3 EPON link, the value is the effective index of refraction for the EPON downstream wavelength light of the optical path (see 13.1.4 and 13.8.1.2.1). The default value is 1.46805 for 1 Gb/s downstream links, and 1.46851 for 10 Gb/s downstream links.

For all other ports, the value is 0.

14.6.24 acceptableMasterTableEnabled

The value is equal to the value of the Boolean acceptableMasterTableEnabled (see 13.1.3.1 and 13.1.3.5).

14.6.25 Port Parameter Data Set Table

There is one Port Parameter Data Set Table per port of a time-aware system. Each Port Parameter Data Set Table contains a set of parameters for each port that supports the time-synchronization capability, as detailed in Table 14-6. Each table can be created or removed dynamically in implementations that support dynamic configuration of ports and components.

Table 14-6—Port Parameter Data Set Table

Name	Data type	Operations supported ^a	Conformance ^b	References
portIdentity	PortIdentity (see 6.3.3.7)	R	T	14.6.2
portRole	Enumeration8	R	T	14.6.3, Table 14-5
pttPortEnabled	Boolean	RW	T	14.6.4
isMeasuringDelay	Boolean	R	T	14.6.5
asCapable	Boolean	R	T	14.6.6
neighborPropDelay	UScaledNs (recommended)	R	T	14.6.7
neighborPropDelayThresh	UScaledNs (recommended)	RW	T	14.6.8
delayAsymmetry	scaledNs (recommended)	RW	Tdot3FD	14.6.9
neighborRateRatio	Integer32	R	T	14.6.10
initialLogAnnounceInterval	Integer8	RW	T	14.6.11
currentLogAnnounceInterval	Integer8	R	T	14.6.12
announceReceiptTimeout	UInteger8	RW	T	14.6.13
initialLogSyncInterval	Integer8	RW	T	14.6.14
currentLogSyncInterval	Integer8	R	T	14.6.15
syncReceiptTimeout	UInteger8	RW	T	14.6.16
syncReceiptTimeoutTime-Interval	UScaledNs	R	T	14.6.17
initialLogPdelayReqInterval	Integer8	RW	T	14.6.18
currentLogPdelayReqInterval	Integer8	R	T	14.6.19
allowedLostResponses	UInteger16	RW	T	14.6.20
versionNumber	UInteger4	R	T	14.6.21
nup	Double	RW	Tdot3OLT	14.6.22
ndown	Double	RW	Tdot3OLT	14.6.23
acceptableMasterTableEnabled	Boolean	RW	Tdot3ONU	14.6.24

^aR = Read only access; RW = Read/write access.

^bT= Required for time-aware port;

Tdot3FD = Required for time-aware IEEE 802.3 full-duplex port;

Tdot3OLT = Required for time-aware IEEE 802.3 EPON OLT ports;

Tdot3ONU = Required for time-aware IEEE 802.3 EPON ONU ports.

14.7 Port Parameter Statistics

The Port Parameter Statistics provides counters associated with port capabilities at a given Bridge or end station.

14.7.1 General

For the single port of a time-aware end station and for each port of a time-aware Bridge, the following Port Parameter Statistics provides counters. The number of such statistics sets is the same as the numberPorts value of the Default Parameter Data Set.

14.7.2 rxSyncCount

A counter that increments every time synchronization is received, denoted by a transition to TRUE from FALSE of the rcvdSync variable of the MDSyncReceiveSM state machine (see 11.2.13.1.2 and Figure 11-6), when in the DISCARD or WAITING_FOR_SYNC states; or rcvdIndication transitions to TRUE (see Figure 12-4).

14.7.3 rxFollowUpCount

A counter that increments every time a Follow_Up message is received, denoted by a transition to TRUE from FALSE of the rcvdFollowUp variable of the MDSyncReceiveSM state machine (see 11.2.13.1.3 and Figure 11-6) when in the WAITING_FOR_FOLLOW_UP state.

14.7.4 rxPdelayRequestCount

A counter that increments every time a Pdelay_Req message is received, denoted by a transition to TRUE from FALSE of the rcvdPdelayReq variable of the MDPdelayResp state machine (see 11.2.16.1.1 and Figure 11-9) when in the WAITING_FOR_PDELAY_REQ or INITIAL_WAITING_FOR_PDELAY_REQ states.

14.7.5 rxPdelayResponseCount

A counter that increments every time a Pdelay_Resp message is received, denoted by a transition to TRUE from FALSE of the rcvdPdelayResp variable of the MDPdelayReq state machine (see 11.2.15.1.2 and Figure 11-8) when in the WAITING_FOR_PDELAY_RESP state.

14.7.6 rxPdelayResponseFollowUpCount

A counter that increments every time a Pdelay_Resp_Follow_Up message is received, denoted by a transition to TRUE from FALSE of the rcvdPdelayRespFollowUp variable of the MDPdelayReq state machine (see 11.2.15.1.4 and Figure 11-8) when in the WAITING_FOR_PDELAY_RESP_FOLLOW_UP state.

14.7.7 rxAnnounceCount

A counter that increments every time an Announce message is received, denoted by a transition to TRUE from FALSE of the rcvdAnnounce variable of the PortAnnounceReceive state machine (see 10.3.10 and Figure 10-12) when in the DISCARD or RECEIVE states.

14.7.8 rxPTPPacketDiscardCount

A counter that increments every time a PTP message is discarded, caused by the occurrence of any of the following conditions:

- a) A received Announce message is not qualified, denoted by the function qualifyAnnounce (see 10.3.10.2.1 and 13.1.3.4) of the PortAnnounceReceive state machine (see 10.3.10 and Figure 10-12) returning FALSE;
- b) A Follow_Up message corresponding to a received Sync message is not received, denoted by a transition of the condition ($\text{currentTime} \geq \text{followUpReceiptTimeoutTime}$) to TRUE from FALSE when in the WAITING_FOR_FOLLOW_UP state of the MDSyncReceiveSM state machine (see 11.2.13 and Figure 11-6);
- c) A Pdelay_Resp message corresponding to a transmitted Pdelay_Req message is not received, denoted by a transition from the WAITING_FOR_PDELAY_RESP state to the RESET state of the MDPdelayReq state machine (see 11.2.15 and Figure 11-8);

- d) A Pdelay_Resp_Follow_Up message corresponding to a transmitted Pdelay_Req message is not received, denoted by a transition from the WAITING_FOR_PDELAY_RESP_FOLLOW_UP state to the RESET state of the MDPdelayReq state machine (see 11.2.15 and Figure 11-8).

14.7.9 syncReceiptTimeoutCount

A counter that increments every time sync receipt timeout occurs, denoted by entering the AGED state of the PortAnnounceInformation state machine (see 10.3.11 and Figure 10-13), with the condition (currentTime >= announceReceiptTimeoutTime) TRUE.

14.7.10 announceReceiptTimeoutCount

A counter that increments every time announce receipt timeout occurs, denoted by entering the AGED state of the PortAnnounceInformation state machine (see 10.3.11 and Figure 10-13), with the condition (currentTime >= syncReceiptTimeoutTime && gmPresent) TRUE.

14.7.11 pdelayAllowedLostResponsesExceededCount

A counter that increments every time the value of the variable lostResponses (see, 11.2.15.1.10) exceeds the value of the variable allowedLostResponses (see 11.2.12.4), in the RESET state of the MDPdelayReq state machine (see 11.2.15 and Figure 11-8).

14.7.12 txSyncCount

A counter that increments every time synchronization information is transmitted, denoted by a transition to TRUE from FALSE of the rcvdMDSync variable of the MDSyncSendSM state machine (see 11.2.14.1.1 and Figure 11-7), when in the INITIALIZING or SEND_FOLLOW_UP states; or the INITIATE_REQUEST_WAIT_CONFIRM state is entered in Figure 12-3.

14.7.13 txFollowUpCount

A counter that increments every time a Follow_Up message is transmitted, denoted by a transition to TRUE from FALSE of the rcvdMDTimestampReceive variable of the MDSyncSendSM state machine (see 11.2.14.1.3 and Figure 11-7), when in the SEND_SYNC state.

14.7.14 txPdelayRequestCount

A counter that increments every time a Pdelay_Req message is transmitted, denoted by entering the INITIAL_SEND_PDELAY_REQ or SEND_PDELAY_REQ states of the MDPdelayReq state machine (see 11.2.15 and Figure 11-8).

14.7.15 txPdelayResponseCount

A counter that increments every time a Pdelay_Resp message is transmitted, denoted by a transition to TRUE from FALSE of the rcvdPdelayReq variable of the MDPdelayResp state machine (see 11.2.16.1.1 and Figure 11-9) when in the WAITING_FOR_PDELAY_REQ or INITIAL_WAITING_FOR_PDELAY_REQ states, and resulting entry to the SENT_PDELAY_RESP_WAITING_FOR_TIMESTAMP state.

14.7.16 txPdelayResponseFollowUpCount

A counter that increments every time a Pdelay_Resp_Follow_Up message is transmitted, denoted by a transition to TRUE from FALSE of the rcvdMDTimestampReceive variable of the MDPdelayResp state machine (see 11.2.16.1.2 and Figure 11-9) when in the SENT_PDELAY_RESP_WAITING_FOR_TIMESTAMP state, and resulting entry to the WAITING_FOR_PDELAY_REQ state.

14.7.17 txAnnounceCount

A counter that increments every time an Announce message is transmitted, denoted by entering the TRANSMIT_ANNOUNCE state of the PortAnnounceReceive state machine (see 10.3.13 and Figure 10-15).

14.7.18 Port Parameter Statistics Table

There is one Port Parameter Statistics Table per port of a time-aware system. Each Port Parameter Statistics Table contains a set of counters for each port that supports the time synchronization capability, as detailed in Table 14-7. Each table can be created or removed dynamically in implementations that support dynamic configuration of ports and components.

Table 14-7—Port Parameter Statistics Table

Name	Data type	Operations supported ^a	Conformance ^b	References
rxSyncCount	UInteger32	R	O	14.7.2
rxFollowUpCount	UInteger32	R	O	14.7.3
rxPdelayRequestCount	UInteger32	R	O	14.7.4
rxPdelayResponseCount	UInteger32	R	O	14.7.5
rxPdelayResponseFollowUp-Count	UInteger32	R	O	14.7.6
rxAnnounceCount	UInteger32	R	O	14.7.7
rxPTPPacketDiscardCount	UInteger32	R	O	14.7.8
syncReceiptTimeoutCount	UInteger32	R	O	14.7.9
announceReceiptTimeout-Count	UInteger32	R	O	14.7.10
pdelayAllowedLostResponses-ExceededCount	UInteger32	R	O	14.7.11
txSyncCount	UInteger32	R	O	14.7.12
txFollowUpCount	UInteger32	R	O	14.7.13
txPdelayRequestCount	UInteger32	R	O	14.7.14
txPdelayResponseCount	UInteger32	R	O	14.7.15
txPdelayResponseFollowUp-Count	UInteger32	R	O	14.7.16
txAnnounceCount	UInteger32	R	O	14.7.17

^aR= Read only access.

^bO= Optional.

14.8 Acceptable Master Table Parameter Data Set

The Acceptable Master Table Parameter Data Set represents the acceptable master table used when an EPON port is present in a time-aware system.

14.8.1 maxTableSize

The value is the maximum size of the AcceptableMasterTable. It is equal to the maxTableSize member of the AcceptableMasterTable structure (see 13.1.3.2).

14.8.2 actualTableSize

The value is the actual size of the AcceptableMasterTable. It is equal to the actualTableSize member of the AcceptableMasterTable structure (see 13.1.3.2 and 13.1.3.5), i.e., the current number of elements in the acceptable master array. The actual table size is less than or equal to the max table size.

14.8.3 acceptableMasterArray

Each element of this array is an AcceptableMaster structure, see 13.1.3.3 and 13.1.3.5.

14.8.4 Acceptable Master Table Parameter Data Set Table

There is one Acceptable Master Table Parameter Data Set Table per time-aware system, as detailed in Table 14-8.

Table 14-8—Acceptable Master Table Parameter Data Set Table

Name	Data type	Operations supported ^a	Conformance ^b	References
maxTableSize	UInteger16	R	Tdot3ONU	14.8.1
actualTableSize	UInteger16	RW	Tdot3ONU	14.8.2
acceptableMasterArray	AcceptableMaster[actualTableSize] (see 13.1.3.3)	RW	Tdot3ONU	14.8.3

^aR = Read only access; RW = Read/write access.

^bTdot3ONU = Required for time-aware IEEE 802.3 EPON ONU ports.

15. Managed object definitions

The clause contains a complete SMIV2 Management Information Base (MIB) set for all features of this standard.

15.1 Internet Standard Management Framework

For a detailed overview of the documents that describe the current Internet Standard Management Framework, please refer to section 7 of IETF RFC 3410 (2002).

Managed objects are accessed via a virtual information store, termed the Management Information Base or MIB. MIB objects are generally accessed through the Simple Network Management Protocol (SNMP). Objects in the MIB are defined using the mechanisms defined in the Structure of Management Information (SMI). This clause specifies a MIB module that is compliant to the SMIV2, which is described in STD 58, IETF RFC 2578, IETF RFC 2579, and IETF RFC 2580.

15.2 Structure of the MIB

The IEEE 802.1AS MIB provides objects to configure and managed the IEEE 802.1AS Timing and Synchronization for Time-Sensitive Applications in Bridged LAN.

The MIB contains a set of textual conventions and is additionally subdivided into seven subtrees. Each subtree is organized as a set of related objects. They are as follows:

- 1) The default data set represents the native capabilities of a time-aware system, a bridge, or an end station.
- 2) The current data set represents topological position of a local system relative to the grandmaster;
- 3) The parent data set represents capabilities of the upstream system, toward the grandmaster as measured at a local system.
- 4) The time properties data set represents capabilities of the grandmaster, as measured at a local system.
- 5) The port data set represents time-aware capabilities at a given bridge or end station port, as a set of augmentation to the interface table entry (ifEntry).
- 6) The port statistics represent statistics and counters associated with time-aware capabilities at a given Bridge or end station port.
- 7) The acceptable master table data set represents the acceptable master table used when media-dependent port type of EPON is present in a time-aware system.

Table 15-1 show the structure of the MIB and the relationship of the MIB objects to the default data set, current data set, parent data set, time properties data set, port data set, port statistics, and acceptable master table data set.

15.3 Security considerations

SNMP versions prior to SNMPv3 did not include adequate security. Even if the network itself is secure (for example by using IPsec), there is no control as to who on the secure network is allowed to access and GET/SET (read/change/create/delete) the objects in these MIB module.

It is recommended that implementers consider the security features as provided by the SNMPv3 framework (see IETF RFC 3410, section 8), including full support for the SNMPv3 cryptographic mechanisms (for authentication and privacy).

Further, deployment of SNMP versions prior to SNMPv3 is not recommended. Instead, it is recommended to deploy SNMPv3 and to enable cryptographic security. It is then a customer/operator responsibility to ensure that the SNMP entity giving access to an instance of these MIB modules is properly configured to give access to the objects only to those principals (users) that have legitimate rights to indeed GET or SET (change/create/delete) them.

There are a number of management objects defined in the IEEE8021-AS MIB module that have a MAX-ACCESS clause of read-write and/or read-create. Such objects may be considered sensitive or vulnerable in some network environments. The support for SET operations in a non-secure environment without proper protection can have a negative effect on network operations.

Some of the readable objects in this MIB module (i.e., objects with a MAX-ACCESS other than notaccessible) may be considered sensitive or vulnerable in some network environments. It is thus important to control all types of access (including GET and/or NOTIFY) to these objects and possibly to even encrypt the values of these objects when sending them over the network via SNMP.

The following objects in the IEEE8021-AS MIB can be manipulated to interfere with the operation of timing synchronization. This could, for example, be used to force a reinitialization of state machines, thus causing timing synchronization and network instability. Another possibility would be for an attacker to override grandmaster status, thus giving a user (or an attacker) unauthorized control over the network time.

Improper manipulation of the following writable objects could result in an unintended grandmaster to be elected, when a system is grandmaster capable in a gPTP domain. It could also be used maliciously to cause frequent grandmaster changes, thereby affecting network stability.

Ieee8021ASDefaultDSPriority1
Ieee8021ASDefaultDSPriority2

Improper manipulation of the following writable objects could result in a segmented time-aware network, could compromise the expected accuracy, and could interrupt paths of the PTP domain.

Ieee8021ASPortDSPttPortEnabled
Ieee8021ASPortDSDelayAsymmetry

Unintended access to any of the readable tables or variables in the IEEE8021-AS MIB alerts the reader that timing synchronization in gPTP domain is configured, and on which values timing parameters are configured, and which system is current grandmaster. This information can suggest to an attacker what applications are being run, and thus suggest application-specific attacks, or to enable the attacker to detect whether their attacks are being successful or not. It is thus important to control even GET access to these objects and possibly to even encrypt the values of these objects when sending them over the network via SNMP.

Table 15-1—IEEE8021-AS MIB structure and object cross reference

MIB table	MIB object	Reference
ieee802AsDefaultDataSet		Default Parameter Data Set Table 14-1
	ieee802AsDefaultDSClockIdentity	14.2.1
	ieee802AsDefaultDSNumberPorts	14.2.2
	ieee802AsDefaultDSClockClass	14.2.3
	ieee802AsDefaultDSClockAccuracy	14.2.4
	ieee802AsDefaultDSOffsetScaledLogVariance	14.2.5
	ieee802AsDefaultDSPriority1	14.2.6
	ieee802AsDefaultDSPriority2	14.2.7
	ieee802AsDefaultDSGmCapable	14.2.8
	ieee802AsDefaultDSCurrentUtcOffset	14.2.9
	ieee802AsDefaultDSCurrentUtcOffsetValid	14.2.10
	ieee802AsDefaultDSLeap59	14.2.11
	ieee802AsDefaultDSLeap61	14.2.12
	ieee802AsDefaultDSTimeTraceable	14.2.13
	ieee802AsDefaultDSFrequencyTraceable	14.2.14
	ieee802AsDefaultDSTimeSource	14.2.15
ieee802AsCurrentDataSet		Current Parameter Data Set Table 14-2
	ieee802AsCurrentDSStepsRemoved	14.3.1
	ieee802AsCurrentDSOffsetFromMaster	14.3.2
	ieee802AsCurrentDSLlastGmPhaseChange	14.3.3
	ieee802AsCurrentDSLlastGmFreqChange	14.3.4
	ieee802AsCurrentDSGmTimebaseIndicator	14.3.5
	ieee802AsCurrentDSGmChangeCount	14.3.6
	ieee802AsCurrentDSTimeOfLastGmChangeEvent	14.3.7
	ieee802AsCurrentDSTimeOfLastGmPhaseChangeEvent	14.3.8
	ieee802AsCurrentDSTimeOfLastGmFreqChangeEvent	14.3.9
ieee802AsParentDataSet		Parent Parameter Data Set Table 14-3
	ieee802AsParentDSParentClockIdentity	14.4.1
	ieee802AsParentDSParentPortNumber	14.4.1
	ieee802AsParentDSCumulativeRateRatio	14.4.2
	ieee802AsParentDSGrandmasterIdentity	14.4.3
	ieee802AsParentDSGrandmasterClockClass	14.4.4
	ieee802AsParentDSGrandmasterClockAccuracy	14.4.5
	ieee802AsParentDSGrandmasterOffsetScaledLogVariance	14.4.6
	ieee802AsParentDSGrandmasterPriority1	14.4.7
	ieee802AsParentDSGrandmasterPriority2	14.4.8
ieee802AsTimePropertiesDataSet		Time Properties Parameter Data Set Table 14-4
	ieee802AsTimePropertiesDSCurrentUTCOffset	14.5.1
	ieee802AsTimePropertiesDSCurrentUTCOffsetValid	14.5.2
	ieee802AsTimePropertiesDSLeap59	14.5.3
	ieee802AsTimePropertiesDSLeap61	14.5.4
	ieee802AsTimePropertiesDSTimeTraceable	14.5.5
	ieee802AsTimePropertiesDSFrequencyTraceable	14.5.6

Table 15-1—IEEE8021-AS MIB structure and object cross reference (continued)

MIB table	MIB object	Reference
	ieee802AsTimePropertiesDSTimeSource	14.5.7
ieee802AsPortDataSet		Port Parameter Data Set Table 14-6
	ieee802AsPortDSClockIdentity	14.6.2
	ieee802AsPortDSPortNumber	14.6.2
	ieee802AsPortDSPortRole	14.6.3
	ieee802AsPortDSPttPortEnabled	14.6.4
	ieee802AsPortDSIsMeasuringDdelay	14.6.5
	ieee802AsPortDSAsCapable	14.6.6
	ieee802AsPortDSNeighborPropDelay	14.6.7
	ieee802AsPortDSNeighborPropDelayThresh	14.6.8
	ieee802AsPortDSDelayAsymmetry	14.6.9
	ieee802AsPortDSNeighborRateRatio	14.6.10
	ieee802AsPortDSInitialLogAnnounceInterval	14.6.11
	ieee802AsPortDSCurrentLogAnnounceInterval	14.6.12
	ieee802AsPortDSAnnounceReceiptTimeout	14.6.13
	ieee802AsPortDSInitialLogSyncInterval	14.6.14
	ieee802AsPortDSCurrentLogSyncInterval	14.6.15
	ieee802AsPortDSSyncReceiptTimeout	14.6.16
	ieee802AsPortDSSyncReceiptTimeoutTimeInterval	14.6.17
	ieee802AsPortDSInitialLogPdelayReqInterval	14.6.18
	ieee802AsPortDSCurrentLogPdelayReqInterval	14.6.19
	ieee802AsPortDSAllowedLostResponses	14.6.20
	ieee802AsPortDSVersionNumber	14.6.21
	ieee802AsPortDSNup	14.6.22
	ieee802AsPortDSNdown	14.6.23
	ieee802AsPortDSAcceptableMasterTableEnabled	14.6.24
ieee802AsPortStatistics		Port Statistics Data Set Table 14-7
	ieee802AsRxSyncCount	14.7.2
	ieee802AsRxFollowUpCount	14.7.3
	ieee802AsRxPdelayRequestCount	14.7.4
	ieee802AsRxPdelayResponseCount	14.7.5
	ieee802AsRxPdelayResponseFollowUpCount	14.7.6
	ieee802AsRxAnnounceCount	14.7.7
	ieee802AsRxPTPPacketDiscardCount	14.7.8
	ieee802AsSyncReceiptTimeoutCount	14.7.9
	ieee802AsAnnounceReceiptTimeoutCount	14.7.10
	ieee802AsPdelayAllowedLostResponsesExceededCount	14.7.11
	ieee802AsTxSyncCount	14.7.12
	ieee802AsTxFollowUpCount	14.7.13
	ieee802AsTxPdelayRequestCount	14.7.14
	ieee802AsTxPdelayResponseCount	14.7.15
	ieee802AsTxPdelayResponseFollowUpCount	14.7.16
	ieee802AsTxAnnounceCount	14.7.17

Table 15-1—IEEE8021-AS MIB structure and object cross reference (continued)

MIB table	MIB object	Reference
ieee802AsAcceptableMasterTableDataSet		Acceptable Master Parameter Data Set Table 14-8
	ieee802AsceptableMasterTableDSMaxTableSize	14.8.1
	ieee802AsceptableMasterTableDSActualTableSize	14.8.2
	ieee802AsceptableMasterTableDSAceptableMaster-Array	14.8.3

15.4 Textual conventions defined in this MIB

The following textual conventions are defined in this MIB:

- a) ClockIdentity. IEEE 802 MAC address represented in “canonical” order defined by IEEE Std 802[®] [B4], EUI-64 [B2].
- b) IEEE8021ASClockClassValue. Clock class value (see 8.6.2.2),
- c) IEEE8021ASClockAccuracyValue. Clock accuracy value (see 8.6.2.3),
- d) IEEE8021ASTimeSourceValue. Source of time used by grandmaster (see 8.6.2.7).

15.5 IEEE 802.1AS MIB module

In the following MIB module, should any discrepancy between the DESCRIPTION text and the corresponding definition in Clause 14 occur, the definition in Clause 14 shall take precedence.

```

IEEE8021-AS-MIB DEFINITIONS ::= BEGIN
-- =====
-- MIB for support of 802.1AS Timing and Synchronization in
-- IEEE 802.1Q Bridged Local Area Networks
-- =====

IMPORTS
    MODULE-IDENTITY, OBJECT-TYPE, Unsigned32, Integer32
        FROM SNMPv2-SMI -- [RFC2578]
    TEXTUAL-CONVENTION, TruthValue, RowStatus, TimeStamp
        FROM SNMPv2-TC -- [RFC2579]
    MODULE-COMPLIANCE, OBJECT-GROUP -- [RFC2580]
        FROM SNMPv2-CONF
    ifGeneralInformationGroup, InterfaceIndexOrZero
        FROM IF-MIB -- [RFC2863]
    IEEE8021BridgePortNumber
        FROM IEEE8021-TC-MIB
    ;

ieee8021AsTimeSyncMib MODULE-IDENTITY
    LAST-UPDATED "201011110000Z" -- November 11, 2010
    ORGANIZATION "IEEE 802.1 Working Group"
    CONTACT-INFO
        "WG-URL: http://www.ieee802.org/1/index.html
        WG-EMail: STDS-802-1@IEEE.ORG

        Contact: Geoffrey M. Garner
        Postal: 196 Ambassador Drive
              Red Bank, NJ 07701
              USA
        E-mail: gmgarner@alum.mit.edu"

    DESCRIPTION
        "The Management Information Base module for
        IEEE 802.1AS time synchronization protocol."

    REVISION "201011110000Z" -- November 11, 2010

    DESCRIPTION
        "Published as part of IEEE Std 802.1AS

        Copyright (C) IEEE (2011)."
```

```

::= { iso(1) org(3) ieee(111)
    standards-association-numbers-series-standards (2)
    lan-man-stds (802) ieee802dot1 (1) ieee802dot1mibs (1) 20 }

ieee8021AsMIBObjects OBJECT IDENTIFIER ::= {ieee8021AsTimeSyncMib 1}
ieee8021AsConformance OBJECT IDENTIFIER ::= {ieee8021AsTimeSyncMib 2}

-- =====
-- Textual Conventions
-- =====

```

```
ClockIdentity ::= TEXTUAL-CONVENTION
  DISPLAY-HINT
    "1x:"
  STATUS current
  DESCRIPTION
    "Represents an IEEE 802 MAC address represented in the
    `canonical' order defined by IEEE 802.1a, EUI-64. EUI-48
    converts to EUI-64 as specified by IEEE. The conversion
    assigns values 255 and 254 to octets 3 and 4 respectively,
    where octet 0 is the most significant and octet 7 the least.
    For example, EUI-48 of AC:DE:48:23:45:67 would extend to
    AC:DE:48:FF:FE:23:45:67."
  REFERENCE    "6.3.3.6 and 8.5.2.2.1"
  SYNTAX OCTET STRING (SIZE (8))

IEEE8021ASClockClassValue ::= TEXTUAL-CONVENTION
  STATUS      current
  DESCRIPTION
    "Clock Class Value from IEEE Std 1588-2008 7.6.2.4,
    with the following interpretation placed on the value:

    6: A clock that is synchronized to a primary reference
        time source,
    7: A clock that has previously been designated as clockClass
        6 but that has lost the ability to synchronize to a primary
        reference time source and is in holdover mode and within
        holdover specifications,
    13: A clock that is synchronized to an application-specific
        source of time,
    14: A clock that has previously been designated as clockClass 13
        but that has lost the ability to synchronize to an
        application-specific source of time and is in holdover mode
        and within holdover specifications,
    52: Degradation alternative A for a clock of clockClass 7 that
        is not within holdover specification,
    58: Degradation alternative A for a clock of clockClass 14 that
        is not within holdover specification,
    68..122: For use by alternate PTP profiles (68..122),
    133..170: For use by alternate PTP profiles (133..170),
    187: Degradation alternative B for a clock of clockClass 7 that
        is not within holdover specification,
    193: Degradation alternative B for a clock of clockClass 14 that
        is not within holdover specification,
    216..232: For use by alternate PTP profiles,
    248: Default none of the other clockClass definitions apply,
    255: A slave-only clock(255)."
```

```
REFERENCE    "14.2.3 and IEEE Std 1588-2008 7.6.2.4"
SYNTAX      INTEGER {
  primarySync(6),
  primarySyncLost(7),
  applicationSpecificSync(13),
  applicationSpecficSyncLost(14),
  primarySyncAlternativeA(52),
```



```

applicationSpecificAlternativeA(58),
primarySyncAlternativeB(187),
applicationSpecficAlternativeB(193),
defaultClock(248),
slaveOnlyClock(255)
}

```

IEEE8021ASClockAccuracyValue ::= TEXTUAL-CONVENTION

STATUS current

DESCRIPTION

"Clock Accuracy Value from 8.6.2.3, with the following interpretation placed on the value:

```

32: The time is accurate to within 25 ns,
33: The time is accurate to within 100 ns,
34: The time is accurate to within 250 ns,
35: The time is accurate to within 1 us,
36: The time is accurate to within 2.5 us,
37: The time is accurate to within 10 us,
38: The time is accurate to within 25 us,
39: The time is accurate to within 100 us,
40: The time is accurate to within 250 us,
41: The time is accurate to within 1 ms,
42: The time is accurate to within 2.5 ms,
43: The time is accurate to within 10 ms,
44: The time is accurate to within 25 ms,
45: The time is accurate to within 100 ms,
46: The time is accurate to within 250 ms,
47: The time is accurate to within 1 s,
48: The time is accurate to within 10 s,
49: The time is accurate to within > 10 s,
254: Default indicating unknown"

```

REFERENCE "8.6.2.3"

```

SYNTAX INTEGER {
timeAccurateTo25ns(32),
timeAccurateTo100ns(33),
timeAccurateTo250ns(34),
timeAccurateTo1us(35),
timeAccurateTo2dot5us(36),
timeAccurateTo10us(37),
timeAccurateTo25us(38),
timeAccurateTo100us(39),
timeAccurateTo250us(40),
timeAccurateTo1ms(41),
timeAccurateTo2dot5ms(42),
timeAccurateTo10ms(43),
timeAccurateTo25ms(44),
timeAccurateTo100ms(45),
timeAccurateTo250ms(46),
timeAccurateTo1s(47),
timeAccurateTo10s(48),
timeAccurateToGT10s(49),
timeAccurateToUnknown(254)
}

```

IEEE8021AStimeSourceValue ::= TEXTUAL-CONVENTION

STATUS current

DESCRIPTION

"The timeSource is an information only attribute indicating the type of source of time used by a ClockMaster, representing categories. For example, the GPS entry would include not only the GPS system of the U.S. Department of Defense but the European Galileo system and other present and future satellite-based timing systems.

In the absence of a default value set by a user of this standard, the default value of timeSource shall be OTHER. See 7.6.2.6 of IEEE Std 1588 - 2008 for more detailed description of timeSourceIndicates the source of time used by the grandmaster clock.

The following interpretation placed on the value:

16: Atomic Clock,
32: GPS,
48: Terrestrial Radio,
64: PTP,
80: NTP,
96: Hand Set,
144: Other,
160: Internal Oscillator "

REFERENCE "8.6.2.7 and Table 8-3"

SYNTAX INTEGER {
atomicClock(16),
gps(32),
terrestrialRadio(48),
ptp(64),
ntp(80),
handSet(96),
other(144),
internalOscillator(160)
}

-- =====
-- subtrees in the IEEE8021-AS-MIB
-- System Time-Aware Parameters/Capability
-- =====

-- =====
-- The Default data set represent native time capability of a time-
-- aware system and is consistent with respective IEEE 1588 data set.
-- =====

ieee8021AsDefaultDS

OBJECT IDENTIFIER ::= { ieee8021AsMIBObjects 1 }

ieee8021AsDefaultDSClockIdentity OBJECT-TYPE

SYNTAX ClockIdentity

```

MAX-ACCESS read-only
STATUS current
DESCRIPTION
    "Globally unique manufacturer-assigned clock identifier
    for the local clock. The identifier is based on an
    EUI-64."
REFERENCE "14.2.1"
::= { ieee8021AsDefaultDS 1 }

```

```

ieee8021AsDefaultDSNumberPorts OBJECT-TYPE
SYNTAX Unsigned32(0..255)
MAX-ACCESS read-only
STATUS current
DESCRIPTION
    "The number of PTP ports on the device.
    For an end station the value is 1."
REFERENCE "14.2.2"
::= { ieee8021AsDefaultDS 2 }

```

```

ieee8021AsDefaultDSClockClass OBJECT-TYPE
SYNTAX IEEE8021ASClockClassValue
MAX-ACCESS read-only
STATUS current
DESCRIPTION
    "Denotes the traceability of the time or frequency of the
    local clock. The value shall be selected as follows:
    a) If the Default Parameter Data Set member gmCapable is
    TRUE, then clockClass is set to the value that
    reflects the combination of the LocalClock and
    ClockSource entities; else if the value that reflects
    the LocalClock and ClockSource entities is not
    specified or not known, clockClass is set to 248;
    b) If the Default Parameter Data Set member gmCapable is
    FALSE (see 8.6.2.1), clockClass is set to 255.
    "
REFERENCE "14.2.3"
DEFVAL { defaultClock }
::= { ieee8021AsDefaultDS 3 }

```

```

ieee8021AsDefaultDSClockAccuracy OBJECT-TYPE
SYNTAX IEEE8021ASClockAccuracyValue
MAX-ACCESS read-only
STATUS current
DESCRIPTION
    "Characterizes local clock for the purpose of the best
    master clock algorithm. The value shall be selected as
    follows:
    a) clockAccuracy is set to the value that reflects the
    combination of the LocalClock and ClockSource
    entities if specified or known;
    b) if the value that reflects the LocalClock and

```

ClockSource entities is not specified or unknown,
clockAccuracy is set to 254.

"

REFERENCE "14.2.4"
 ::= { ieee8021AsDefaultDS 4 }

ieee8021AsDefaultDSOffsetScaledLogVariance OBJECT-TYPE

SYNTAX Integer32(-32768..32767)

MAX-ACCESS read-only

STATUS current

DESCRIPTION

"The offsetScaledLogVariance is scaled, offset representation of an estimate of the PTP variance. The PTP variance characterizes the precision and frequency stability of the ClockMaster. The PTP variance is the square of PTPDEV (see B.1.3.2). The value shall be selected as follows:

- a) offsetScaledLogVariance is set to the value that reflects the combination of the LocalClock and ClockSource entities; else
- b) if the value that reflects these entities is not specified or not known, offsetScaledLogVariance is set to 16640 (410016). This value corresponds to the value of PTPDEV for observation interval equal to the default Sync message transmission interval (i.e., observation interval of 0.125 s, see 11.5.2.3 and B.1.3.2).

A value of -37268 indicates value is too large to be represented or has not been computed.

"

REFERENCE "14.2.5"
 ::= { ieee8021AsDefaultDS 5 }

ieee8021AsDefaultDSPriority1 OBJECT-TYPE

SYNTAX Unsigned32(0..255)

MAX-ACCESS read-write

STATUS current

DESCRIPTION

"Most-significant priority declaration in the execution of the best master clock algorithm. Lower values take precedence. The value of priority1 shall be 255 for a time-aware system that is not grandmaster-capable. The value of priority1 shall be less than 255 for a time-aware system that is grandmaster-capable. The value 0 shall be reserved for future management use, i.e., the value of priority1 shall be set to 0 only via management action, and shall not be specified as a default value by a user of this standard. In the absence of a default value set by a user of this standard, the default value shall be set as below:

a) system type of network infrastructure time-aware system to value 246;
 b) portable time-aware system, 250;
 c) other time-aware systems, 248."
 REFERENCE "14.2.6"
 ::= { ieee8021AsDefaultDS 6 }

ieee8021AsDefaultDSPriority2 OBJECT-TYPE
 SYNTAX Unsigned32(0..255)
 MAX-ACCESS read-write
 STATUS current
 DESCRIPTION
 "Least-significant priority declaration in the execution of the best master clock algorithm. Lower values take precedence. The default value is 248"
 REFERENCE "14.2.7"
 DEFVAL { 248 }
 ::= { ieee8021AsDefaultDS 7 }

ieee8021AsDefaultDSGmCapable OBJECT-TYPE
 SYNTAX TruthValue
 MAX-ACCESS read-only
 STATUS current
 DESCRIPTION
 "True (1) if master clock capable; false (2) otherwise."
 REFERENCE "14.2.8"
 ::= { ieee8021AsDefaultDS 8 }

ieee8021AsDefaultDSCurrentUTCOffset OBJECT-TYPE
 SYNTAX Integer32(-32768..32767)
 UNITS "seconds"
 MAX-ACCESS read-only
 STATUS current
 DESCRIPTION
 "The value is the offset between TAI and UTC, relative to the ClockMaster entity of this time-aware system. It is equal to the global variable sysCurrentUtcOffset (see 10.3.8.16). The value is in units of seconds. The initialization default value is selected as follows:
 a) the value is the value obtained from a primary reference if the value is known at the at the time of initialization,
 b) else the value is the current number of leap seconds, see 8.2.3, when the time-aware system is designed."
 REFERENCE "14.2.9"
 ::= { ieee8021AsDefaultDS 9 }

```
ieee8021AsDefaultDSCurrentUTCOffsetValid OBJECT-TYPE
    SYNTAX      TruthValue
    MAX-ACCESS  read-only
    STATUS      current
    DESCRIPTION
        "True (1) if ieee8021AsDefaultDSCurrentUTCOffset is known
        to be correct; false (2) otherwise."
    REFERENCE   "14.2.10"
    ::= { ieee8021AsDefaultDS 10 }
```

```
ieee8021AsDefaultDSLeap59 OBJECT-TYPE
    SYNTAX      TruthValue
    MAX-ACCESS  read-only
    STATUS      current
    DESCRIPTION
        "A true (1) value indicates that the last minute of the
        current UTC day, relative to the ClockMaster entity of
        this time-aware system, will contain 59 seconds. It is
        equal to the global variable sysLeap59 (see 10.3.8.12).

        The initialization value is selected as follows:
        a) Set to true (1) if the value is obtained from a
           primary reference if known at the at the time of
           initialization, else
        b) The value is set to false (2)."
```

```
    REFERENCE   "14.2.11"
    ::= { ieee8021AsDefaultDS 11 }
```

```
ieee8021AsDefaultDSLeap61 OBJECT-TYPE
    SYNTAX      TruthValue
    MAX-ACCESS  read-only
    STATUS      current
    DESCRIPTION
        "A true (1) value indicates that the last minute of the
        current UTC day, relative to the ClockMaster entity of
        this time-aware system, will contain 59 seconds. It is
        equal to the global variable sysLeap61 (see 10.3.8.11).

        The initialization value is selected as follows:
        a) Set to true (1) if the value is obtained from a
           primary reference if known at the at the time of
           initialization, else
        b) The value is set to false (2)."
```

```
    REFERENCE   "14.2.12"
    ::= { ieee8021AsDefaultDS 12 }
```

```
ieee8021AsDefaultDSTimeTraceable OBJECT-TYPE
    SYNTAX      TruthValue
    MAX-ACCESS  read-only
    STATUS      current
    DESCRIPTION
```

"The value is set to true (1) if the timescale and the value of `Ieee8021AsCurrentUtcOffset`, relative to the `ClockMaster` entity of this time-aware system, are traceable to a primary reference standard; otherwise the value is set to false (2). It is equal to the global variable `sysTimeTraceable` (see 10.3.8.14).

The initialization value is selected as follows:

- a) If the time and the value of `currentUtcOffset` are traceable to a primary reference standard at the time of initialization, the value is set to true (1), else
- b) The value is set to false (2)."

REFERENCE "14.2.13"
 ::= { ieee8021AsDefaultDS 13 }

`ieee8021AsDefaultDSFrequencyTraceable` OBJECT-TYPE

SYNTAX TruthValue
MAX-ACCESS read-only
STATUS current
DESCRIPTION

"The value is set to true (1) if the frequency determining the timescale of the `ClockMaster` Entity of this time-aware system is traceable to a primary reference standard; otherwise the value is set to false (2). It is equal to the global variable `sysFrequencyTraceable` (see 10.3.8.15).

The initialization value is selected as follows:

- a) If the frequency is traceable to a primary reference standard at the time of initialization, the value is set to true (1), else
- b) The value is set to false (2).."

REFERENCE "14.2.14"
 ::= { ieee8021AsDefaultDS 14 }

`ieee8021AsDefaultDSTimeSource` OBJECT-TYPE

SYNTAX IEEE8021ASTimeSourceValue
MAX-ACCESS read-only
STATUS current
DESCRIPTION

"The `timeSource` is an information-only attribute indicating the type of source of time used by a `ClockMaster`. The value is not used in the selection of the grandmaster. The values shall be as specified in Table 8-3. These represent categories. For example, the GPS entry would include not only the GPS system of the U.S. Department of Defense but the European Galileo system and other present and future satellite-based timing systems. All unused values in Table 8-3 are reserved.

```

The initialization value is selected as follows:
a) If the timeSource (8.6.2.7 and Table 8-3), is known
   at the time of initialization, the value is derived
   from the table, else
b) The value is set to INTERNAL_OSCILLATOR (160).
"
REFERENCE    "14.2.15"
::= { ieee8021AsDefaultDS 15 }

-- =====
-- The Current data set represent this system's topological location
-- relative to the known grandmaster system.
-- This data set is consistent with respective IEEE 1588 data set.
-- =====
ieee8021AsCurrentDS
    OBJECT IDENTIFIER ::= { ieee8021AsMIBObjects 2 }

ieee8021AsCurrentDSStepsRemoved OBJECT-TYPE
    SYNTAX      Integer32(-32768..32767)
    MAX-ACCESS  read-only
    STATUS      current
    DESCRIPTION
        "The number of communication paths traversed between the
        local clock and the grandmaster clock (see Table 10.3.3).

        For example, stepsRemoved for a slave clock on the same
        PTP communication path as the grandmaster clock will have
        a value of 1, indicating that a single path was traversed."
"
REFERENCE    "14.3.1"
DEFVAL { 0 }
::= { ieee8021AsCurrentDS 1 }

ieee8021AsCurrentDSOffsetFromMasterHs OBJECT-TYPE
    SYNTAX      Integer32
    UNITS       "2**-16 ns * 2**64"
    MAX-ACCESS  read-only
    STATUS      current
    DESCRIPTION
        "The most significant 32 bits of the offset, signed
        96 bit number in 2**-16 ns, an implementation-specific
        computation of the current value of the time difference
        between a master and a slave as computed by the slave.

        This object MUST be read at the same time as
        ieee8021AsCurrentDSOffsetFromMasterMs, and
        ieee8021AsCurrentDSOffsetFromMasterLs, which
        represents middle and least significant 32 bits of
        values, respectively, in order for the read operation
        to succeed."
"
REFERENCE    "14.3.2"

```

::= { ieee8021AsCurrentDS 2 }

ieee8021AsCurrentDSOffsetFromMasterMs OBJECT-TYPE

SYNTAX Integer32
 UNITS "2**⁻¹⁶ ns * 2**³²"
 MAX-ACCESS read-only
 STATUS current
 DESCRIPTION

"The middle significant 32 bits of the offset, signed 96 bit number in 2**⁻¹⁶ ns, an implementation-specific computation of the current value of the time difference between a master and a slave as computed by the slave.

This object MUST be read at the same time as ieee8021AsCurrentDSOffsetFromMasterHs, and ieee8021AsCurrentDSOffsetFromMasterLs, which represents most (highest) and least significant 32 bits of values, respectively, in order for the read operation to succeed.

"

REFERENCE "14.3.2"

::= { ieee8021AsCurrentDS 3 }

ieee8021AsCurrentDSOffsetFromMasterLs OBJECT-TYPE

SYNTAX Integer32
 UNITS "2**⁻¹⁶ ns"
 MAX-ACCESS read-only
 STATUS current
 DESCRIPTION

"The least significant 32 bits of the offset, signed 96 bit number in 2**⁻¹⁶ ns, an implementation-specific computation of the current value of the time difference between a master and a slave as computed by the slave.

This object MUST be read at the same time as ieee8021AsCurrentDSOffsetFromMasterHs, and ieee8021AsCurrentDSOffsetFromMasterMs, which represents most (highest) and middle significant 32 bits of values, respectively, in order for the read operation to succeed.

"

REFERENCE "14.3.2"

::= { ieee8021AsCurrentDS 4 }

ieee8021AsCurrentDSLstGmPhaseChangeHs OBJECT-TYPE

SYNTAX Integer32
 MAX-ACCESS read-only
 STATUS current
 DESCRIPTION

"The value (see 10.2.3.16) is the phase change that occurred on the most recent change in either grandmaster or gmTimeBaseIndicator (see 9.2.2.2).

This object MUST be read at the same time as

ieee8021AsCurrentDSLstGmPhaseChangeMs, and
ieee8021AsCurrentDSLstGmPhaseChangeLs, which
represents middle and least significant 32 bits of
values, respectively, in order for the read operation
to succeed.

"

REFERENCE "14.3.3"
 ::= { ieee8021AsCurrentDS 5}

ieee8021AsCurrentDSLstGmPhaseChangeMs OBJECT-TYPE

SYNTAX Unsigned32
MAX-ACCESS read-only
STATUS current
DESCRIPTION

"The value (see 10.2.3.16) is the phase change that
occurred on the most recent change in either
grandmaster or gmTimeBaseIndicator (see 9.2.2.2).

This object MUST be read at the same time as
ieee8021AsCurrentDSLstGmPhaseChangeHs, and
ieee8021AsCurrentDSLstGmPhaseChangeLs, which
represents most and least significant 32 bits of
values, respectively, in order for the read operation
to succeed.

"

REFERENCE "14.3.3"
 ::= { ieee8021AsCurrentDS 6}

ieee8021AsCurrentDSLstGmPhaseChangeLs OBJECT-TYPE

SYNTAX Unsigned32
MAX-ACCESS read-only
STATUS current
DESCRIPTION

"The value (see 10.2.3.16) is the phase change that
occurred on the most recent change in either
grandmaster or gmTimeBaseIndicator (see 9.2.2.2).

This object MUST be read at the same time as
ieee8021AsCurrentDSLstGmPhaseChangeMs, and
ieee8021AsCurrentDSLstGmPhaseChangeLs, which
represents middle and least significant 32 bits of
values, respectively, in order for the read operation
to succeed.

"

REFERENCE "14.3.3"
 ::= { ieee8021AsCurrentDS 7}

ieee8021AsCurrentDSLstGmFreqChangeMs OBJECT-TYPE

SYNTAX Integer32
MAX-ACCESS read-only
STATUS current
DESCRIPTION

"The value (see 10.2.3.17) is the frequency change that

occurred on the most recent change in either grandmaster or gmTimeBaseIndicator (see 9.2.2.2).

This object MUST be read at the same time as ieee8021AsCurrentDSLstGmFreqChangeLs, which represents least significant 32 bits of the value in order for the read operation to succeed.

REFERENCE "14.3.4"
 ::= { ieee8021AsCurrentDS 8 }

ieee8021AsCurrentDSLstGmFreqChangeMs OBJECT-TYPE

SYNTAX Unsigned32
MAX-ACCESS read-only
STATUS current
DESCRIPTION

"The value (see 10.2.3.17) is the frequency change that occurred on the most recent change in either grandmaster or gmTimeBaseIndicator (see 9.2.2.2).

This object MUST be read at the same time as ieee8021AsCurrentDSLstGmFreqChangeLs, which represents most significant 32 bits of the value in order for the read operation to succeed.

REFERENCE "14.3.4"
 ::= { ieee8021AsCurrentDS 9 }

ieee8021AsCurrentDSGmTimebaseIndicator OBJECT-TYPE

SYNTAX Unsigned32(0..65535)
MAX-ACCESS read-only
STATUS current
DESCRIPTION

"This reports the grandmaster's time base change value conveyed in the Sync message. The value is the value of timeBaseIndicator of the current grandmaster (see 9.2.2.2 and 9.6.2.2)

REFERENCE "14.3.5"
 ::= { ieee8021AsCurrentDS 10 }

ieee8021AsCurrentDSGmChangeCount OBJECT-TYPE

SYNTAX Counter32
MAX-ACCESS read-only
STATUS current
DESCRIPTION

"This statistics counter tracks the number of times the grandmaster has changed in a gPTP domain. This counter increments when the PortAnnounceInformation state machine enters the SUPERIOR_MASTER_PORT state or the INFERIOR_MASTER_OR_OTHER_PORT state (see 10.3.11 and Figure 10-13).

REFERENCE "14.3.6"

```
::= { ieee8021AsCurrentDS 11 }
```

```
ieee8021AsCurrentDSTimeOfLastGmChangeEvent OBJECT-TYPE
```

```
SYNTAX      TimeStamp
```

```
UNITS       "0.01 seconds"
```

```
MAX-ACCESS  read-only
```

```
STATUS      current
```

```
DESCRIPTION
```

```
"This timestamp denotes the system time when the most recent grandmaster change occurred in a gPTP domain. This timestamp is updated when the PortAnnounceInformation state machine enters the SUPERIOR_MASTER_PORT state or the INFERIOR_MASTER_OR_OTHER_PORT state (see 10.3.11 and Figure 10-13)."
```

```
REFERENCE   "14.3.7"
```

```
::= { ieee8021AsCurrentDS 12 }
```

```
ieee8021AsCurrentDSTimeOfLastGmFreqChangeEvent OBJECT-TYPE
```

```
SYNTAX      TimeStamp
```

```
UNITS       "0.01 seconds"
```

```
MAX-ACCESS  read-only
```

```
STATUS      current
```

```
DESCRIPTION
```

```
"This timestamp denotes the system time when the most recent change in grandmaster phase occurred, due to a change of either the grandmaster or the grandmaster time base. This timestamp is updated when the PortAnnounceInformation state machine enters the SUPERIOR_MASTER_PORT state or the INFERIOR_MASTER_OR_OTHER_PORT state (see 10.3.11 and Figure 10-13), and when the ieee802AsCurrentDSGmTimebaseIndicator managed object (see 14.3.5) changes."
```

```
REFERENCE   "14.3.8"
```

```
::= { ieee8021AsCurrentDS 13 }
```

```
ieee8021AsCurrentDSTimeOfLastGmPhaseChangeEvent OBJECT-TYPE
```

```
SYNTAX      TimeStamp
```

```
UNITS       "0.01 seconds"
```

```
MAX-ACCESS  read-only
```

```
STATUS      current
```

```
DESCRIPTION
```

```
"This timestamp denotes the system time when the most recent change in grandmaster frequency occurred, due to a change of either the grandmaster or the grandmaster time base. This timestamp is updated when the PortAnnounceInformation state machine enters the SUPERIOR_MASTER_PORT state or the INFERIOR_MASTER_OR_OTHER_PORT state (see 10.3.11 and Figure 10-13), and when the ieee802AsCurrentDSGmTimebaseIndicator managed object
```

```

        (see 14.3.5) changes.
    "
REFERENCE    "14.3.9"
 ::= { ieee8021AsCurrentDS 14 }

-- =====
-- The Parent data set represent timing upstream (toward grandmaster)
-- system's parameters as measured at this system.
-- This data set is consistent with respective IEEE 1588 data set.
-- =====
ieee8021AsParentDS
    OBJECT IDENTIFIER ::= { ieee8021AsMIBObjects 3 }

ieee8021AsParentDSParentClockIdentity OBJECT-TYPE
    SYNTAX      ClockIdentity
    MAX-ACCESS  read-only
    STATUS      current
    DESCRIPTION
        "Clock identifier (clockIdentity) of the local clock's
        parent clock. The default value is set to
        ieee8021AsDefaultDSClockIdentity.

        If this time-aware system is the grandmaster, the value
        is the clockIdentity of this time-aware system.
        If this time-aware system is not the grandmaster, the
        value is the clockIdentity of the MasterPort (see
        Table 10-1) of the gPTP communication path attached to
        the single slave port of this time-aware system.
        "
    REFERENCE   "14.4.1"
    ::= { ieee8021AsParentDS 1 }

ieee8021AsParentDSParentPortNumber OBJECT-TYPE
    SYNTAX      Unsigned32(0..65535)
    MAX-ACCESS  read-only
    STATUS      current
    DESCRIPTION
        "Port number (portNumber) of the local clock's parent gPTP
        port number.

        If this time-aware system is the grandmaster, the value
        is the gPTP portNumber of this time-aware system.
        If this time-aware system is not the grandmaster, the
        value is the portNumber of the MasterPort (see
        Table 10-1) of the gPTP communication path attached to
        the single gPTP slave port of this time-aware system.
        "
    REFERENCE   "14.4.1"
    DEFVAL { 0 }
    ::= { ieee8021AsParentDS 2 }

ieee8021AsParentDSCumulativeRateRatio OBJECT-TYPE
    SYNTAX      Integer32

```

```
MAX-ACCESS read-only
STATUS current
DESCRIPTION
    "The value is an estimate of the ratio of the frequency
    of the grandmaster to the frequency of the LocalClock
    entity of this time-aware system.

    Cumulative rate ratio is expressed as the fractional
    frequency offset multiplied by 2**41, i.e., the
    quantity (rateRatio - 1.0)(2**41), where rateRatio is
    computed by the PortSyncSyncReceive state machine (see
    10.2.7.1.4).
"
REFERENCE "14.4.2"
::= { ieee8021AsParentDS 3 }

ieee8021AsParentDSGrandmasterIdentity OBJECT-TYPE
SYNTAX ClockIdentity
MAX-ACCESS read-only
STATUS current
DESCRIPTION
    "Clock identifier (clockIdentity) of the grandmaster.
    The default value is set to
    ieee8021AsDefaultDSClockIdentity."
REFERENCE "14.4.3"
::= { ieee8021AsParentDS 4 }

ieee8021AsParentDSGrandmasterClockClass OBJECT-TYPE
SYNTAX IEEE8021ASClockClassValue
MAX-ACCESS read-only
STATUS current
DESCRIPTION
    "Denotes the traceability of the time or frequency of the
    grandmaster. The default value is set to
    ieee8021AsDefaultDSClockClass."
REFERENCE "14.4.4"
::= { ieee8021AsParentDS 5 }

ieee8021AsParentDSGrandmasterClockAccuracy OBJECT-TYPE
SYNTAX IEEE8021ASClockAccuracyValue
MAX-ACCESS read-only
STATUS current
DESCRIPTION
    "Characterizes the grandmaster clock for the purpose of
    the best master clock algorithm. The default value is
    set to ieee8021AsDefaultDSClockAccuracy."
REFERENCE "14.4.5"
::= { ieee8021AsParentDS 6 }

ieee8021AsParentDSGrandmasterOffsetScaledLogVariance OBJECT-TYPE
SYNTAX Integer32(-32768..32767)
MAX-ACCESS read-only
STATUS current
DESCRIPTION
```

```

        "Clock Allan variance of the local clock expressed as a
        base-2 logarithm multiplied by a scale factor of 256.
        Hysteresis is applied requiring the underlying computed
        variance to move by at least 128 before a change is
        reported. A value of -37268 indicates value is too large
        to be represented or has not been computed.
        The default value is set to
        ieee8021AsDefaultDSOffsetScaledLogVariance."
REFERENCE    "14.4.6"
 ::= { ieee8021AsParentDS 7 }

ieee8021AsParentDSGrandmasterPriority1 OBJECT-TYPE
SYNTAX      Unsigned32(0..255)
MAX-ACCESS  read-write
STATUS      current
DESCRIPTION
    "Grandmaster's most-significant priority declaration in
    the execution of the best master clock algorithm.
    Lower values take precedence. The default value is set
    to ieee8021AsDefaultDSPriority1."
REFERENCE    "14.4.7"
 ::= { ieee8021AsParentDS 8 }

ieee8021AsParentDSGrandmasterPriority2 OBJECT-TYPE
SYNTAX      Unsigned32(0..255)
MAX-ACCESS  read-write
STATUS      current
DESCRIPTION
    "Grandmaster's least-significant priority declaration in
    the execution of the best master clock algorithm.
    Lower values take precedence. The default value is set to
    ieee8021AsDefaultDSDSPriority2."
REFERENCE    "14.4.8"
 ::= { ieee8021AsParentDS 9 }

-- =====
-- TimePropertiesDS represents the grandmaster's parameters, as
-- measured at this system and are derived from 802.1AS protocol.
-- This data set is consistent with respective IEEE 1588 data set.
-- =====
ieee8021AsTimePropertiesDS
    OBJECT IDENTIFIER ::= { ieee8021AsMIBObjects 4 }

ieee8021AsTimePropertiesDSCurrentUtcOffset OBJECT-TYPE
SYNTAX      Integer32(-32768..32767)
UNITS      "seconds"
MAX-ACCESS  read-only
STATUS      current
DESCRIPTION
    "The value is currentUtcOffset for the current grandmaster
    (see Table 14.2.9). It is equal to the value of the global
    variable currentUtcOffset (see 10.3.8.9). The value is in
    units of seconds. The default value is set to
    ieee8021AsDefaultDSCurrentUTCOffset."

```

REFERENCE "14.5.1"
 ::= { ieee8021AsTimePropertiesDS 1 }

ieee8021AsTimePropertiesDSCurrentUtcOffsetValid OBJECT-TYPE

SYNTAX TruthValue
MAX-ACCESS read-only
STATUS current
DESCRIPTION
 "True (1) if ieee8021AsTimePropertiesDSCurrentUTCOffset
 is known to be correct; false (2) otherwise. The default
 value is set to ieee8021AsDefaultDSCurrentUTCOffsetValid.

"

REFERENCE "14.5.2"
 ::= { ieee8021AsTimePropertiesDS 2 }

ieee8021AsTimePropertiesDSLeap59 OBJECT-TYPE

SYNTAX TruthValue
MAX-ACCESS read-only
STATUS current
DESCRIPTION
 "The value is leap59 for the current grandmaster (see
 14.2.11). It is equal to the global variable leap59
 (see 10.3.8.5).

 A true (1) value indicates that the last minute of the
 current UTC day, relative to the ClockMaster entity of
 this time-aware system, will contain 59 seconds.

The default value is set to

ieee8021AsDefaultDSLeap59."

REFERENCE "14.5.3"
 ::= { ieee8021AsTimePropertiesDS 3 }

ieee8021AsTimePropertiesDSLeap61 OBJECT-TYPE

SYNTAX TruthValue
MAX-ACCESS read-only
STATUS current
DESCRIPTION
 "The value is leap61 for the current grandmaster (see
 14.2.12). It is equal to the global variable leap59
 (see 10.3.8.4).

 A true (1) value indicates that the last minute of the
 current UTC day, relative to the ClockMaster entity of
 this time-aware system, will contain 61 seconds. The

default value is set to

ieee8021AsDefaultDSLeap61."

REFERENCE "14.5.4"
 ::= { ieee8021AsTimePropertiesDS 4 }

ieee8021AsTimePropertiesDSTimeTraceable OBJECT-TYPE

SYNTAX TruthValue
MAX-ACCESS read-only

```

STATUS      current
DESCRIPTION
    "The value is timeTraceable for the current grandmaster
    (see 14.2.13). It is equal to the global variable
    timeTraceable (see 10.3.8.7).

    True (1) if the timescale and the value of
    timePropertiesDSCurrentUTCOffset are traceable to a
    primary reference; false (2) otherwise. The default
    value is set to ieee8021AsDefaultDSTimeTraceable."

REFERENCE   "14.5.5"
::= { ieee8021AsTimePropertiesDS 5 }

```

ieee8021AsTimePropertiesDSFrequencyTraceable OBJECT-TYPE

```

SYNTAX      TruthValue
MAX-ACCESS  read-only
STATUS      current
DESCRIPTION
    "The value is frequencyTraceable for the current
    grandmaster (see 14.2.14). It is equal to the global
    variable frequencyTraceable (see 10.3.8.8).

    True (1) if the frequency determining the timescale is
    traceable to a primary reference; false (2) otherwise.
    The default value is set to
    ieee8021AsDefaultDSFrequencyTraceable."

REFERENCE   "14.5.6"
::= { ieee8021AsTimePropertiesDS 6 }

```

ieee8021AsTimePropertiesDSTimeSource OBJECT-TYPE

```

SYNTAX      IEEE8021ASTimeSourceValue
MAX-ACCESS  read-only
STATUS      current
DESCRIPTION
    "The value is timeSource for the current grandmaster
    (see 14.2.15). It is equal to the global variable
    timeTraceable (see 10.3.8.10).

    Indicates the source of time used by the grandmaster
    clock.
    The default value is set to
    ieee8021AsDefaultDSTimeSource."

REFERENCE   "14.5.7"
::= { ieee8021AsTimePropertiesDS 7 }

```

```

-- =====
-- The Time-Sync parameters for each .1AS capable (gPTP) port.
-- One Table per Bridge Component or a end station.
-- One entry per gPTP port.
-- =====

```

```

ieee8021AsPortDSIfTable OBJECT-TYPE
    SYNTAX      SEQUENCE OF Ieee8021AsPortDSIfEntry
    MAX-ACCESS  not-accessible
    STATUS      current
    DESCRIPTION
        "A table of gPTP port related variables in a time-aware
        Bridge or for a time-aware end station. A value of 1 is used in
        a bridge or an end station that does not have multiple
        components.

        For a given media port of a Bridge or an end station, there may
        be one or more gPTP port, and depends whether a media port
        supports point to point link (e.g. IEEE 802.3 Ethernet) or point
        to multi-point (e.g. CSN, IEEE 802.3 EPON, etc) links on the
        media port.
        "
    REFERENCE
        "IEEE 802.1AS clause 14.6"
    ::= { ieee8021AsMIBObjects 5 }

ieee8021AsPortDSIfEntry OBJECT-TYPE
    SYNTAX      Ieee8021AsPortDSIfEntry
    MAX-ACCESS  not-accessible
    STATUS      current
    DESCRIPTION
        "A list of objects pertaining to a gPTP port of a time-aware
        bridge component or a time-aware end station.
        "
    INDEX { ieee8021AsBridgeBasePort,
            ieee8021AsPortDSAsIfIndex }
    ::= { ieee8021AsPortDSIfTable 1 }

Ieee8021AsPortDSIfEntry ::=
    SEQUENCE {
        ieee8021AsBridgeBasePort          IEEE8021BridgePortNumber,
        ieee8021AsPortDSAsIfIndex         Integer32,
        ieee8021AsPortDSClockIdentity     ClockIdentity,
        ieee8021AsPortDSPortNumber        Unsigned32,
        ieee8021AsPortDSPortRole           INTEGER,
        ieee8021AsPortDSPttPortEnabled    TruthValue,
        ieee8021AsPortDSIsMeasuringDelay   TruthValue,
        ieee8021AsPortDSAsCapable          TruthValue,
        ieee8021AsPortDSNeighborPropDelayHs Unsigned32,
        ieee8021AsPortDSNeighborPropDelayMs Unsigned32,
        ieee8021AsPortDSNeighborPropDelayLs Unsigned32,
        ieee8021AsPortDSNeighborPropDelayThreshHs Unsigned32,
        ieee8021AsPortDSNeighborPropDelayThreshMs Unsigned32,
        ieee8021AsPortDSNeighborPropDelayThreshLs Unsigned32,
        ieee8021AsPortDSDelayAsymmetryHs   Integer32,
        ieee8021AsPortDSDelayAsymmetryMs   Unsigned32,
        ieee8021AsPortDSDelayAsymmetryLs   Unsigned32,
        ieee8021AsPortDSNeighborRateRatio   Integer32,
        ieee8021AsPortDSInitialLogAnnounceInterval Integer32,
        ieee8021AsPortDSCurrentLogAnnounceInterval Integer32,

```

```

ieee8021AsPortDSAnnounceReceiptTimeout      Unsigned32,
ieee8021AsPortDSInitialLogSyncInterval      Integer32,
ieee8021AsPortDSCurrentLogSyncInterval      Integer32,
ieee8021AsPortDSSyncReceiptTimeout          Unsigned32,
ieee8021AsPortDSSyncReceiptTimeoutTimeIntervalHs Unsigned32,
ieee8021AsPortDSSyncReceiptTimeoutTimeIntervalMs Unsigned32,
ieee8021AsPortDSSyncReceiptTimeoutTimeIntervalLs Unsigned32,
ieee8021AsPortDSInitialLogPdelayReqInterval Integer32,
ieee8021AsPortDSCurrentLogPdelayReqInterval Integer32,
ieee8021AsPortDSAllowedLostResponses        Unsigned32,
ieee8021AsPortDSVersionNumber               Unsigned32,
ieee8021AsPortDSNupMs                       Unsigned32,
ieee8021AsPortDSNupLs                       Unsigned32,
ieee8021AsPortDSNdownMs                     Unsigned32,
ieee8021AsPortDSNdownLs                     Unsigned32,
ieee8021AsPortDSAcceptableMasterTableEnabled TruthValue
}

```

ieee8021AsBridgeBasePort OBJECT-TYPE

```

SYNTAX      IEEE8021BridgePortNumber
MAX-ACCESS  not-accessible
STATUS      current
DESCRIPTION

```

"This object identifies the bridge port number of the port for which this entry contains bridge management information. For end stations, this port number shall be (1)."

```

REFERENCE   "IEEE Std 802.1AS PortDS Group gPTP Port Index"
 ::= { ieee8021AsPortDSIfEntry 1 }

```

ieee8021AsPortDSAsIfIndex OBJECT-TYPE

```

SYNTAX      InterfaceIndexOrZero
MAX-ACCESS  not-accessible
STATUS      current
DESCRIPTION

```

"This object identifies the gPTP interface group within the system for which this entry contains information. It is the value of the instance of the IfIndex object, defined in the IF-MIB, for the gPTP interface group corresponding to this port, or the value 0 if the port has not been bound to an underlying frame source and sink.

For a given media port of a Bridge or an end station, there may be one or more gPTP port, and depends whether a media port supports point to point link (e.g. IEEE 802.3 Ethernet) or point to multi-point (e.g. CSN, IEEE 802.3 EPON, etc) links on the media port."

```

REFERENCE   "IEEE Std 802.1AS PortDS Group gPTP Port Index"
 ::= { ieee8021AsPortDSIfEntry 2 }

```

ieee8021AsPortDSClockIdentity OBJECT-TYPE

```

SYNTAX      ClockIdentity
MAX-ACCESS  read-only

```

STATUS current
DESCRIPTION "The clockIdentity is an 8 octet array formed by mapping an IEEE EUI-48 assigned to the time-aware system to IEEE EUI-64 format (i.e., to an array of 8 octets). The EUI-48 shall be an Ethernet MAC address owned by the organization creating the instance of a clockIdentity under the terms of this subclause. The organization owning the MAC address shall ensure that the MAC address is used in generating only a single instance of a clockIdentity, for example by requiring that the MAC address be a MAC address embedded in the device identified by the clockIdentity. The mapping rules for constructing the EUI-64 from the EUI-48 shall be those specified by the IEEE [B2]. The 8 octets of the created IEEE EUI-64 shall be assigned in order to the 8 octet array clockIdentity with most significant octet of the IEEE EUI-64 assigned to the clockIdentity octet array member with index 0.(see 8.5.2.2)."

REFERENCE "14.6.2"
 ::= { ieee8021AsPortDSIfEntry 3 }

ieee8021AsPortDSPortNumber OBJECT-TYPE
SYNTAX Unsigned32(0..65535)
MAX-ACCESS read-only
STATUS current
DESCRIPTION "The portNumber value for a port on a time-aware end station (i.e., a time-aware system supporting a single gPTP port) shall be 1. The portNumber values for the gPTP ports on a time-aware bridgeBridge supporting N ports shall be 1, 2, ..., N, respectively (see 8.5.2.3) ."

REFERENCE "14.6.2"
 ::= { ieee8021AsPortDSIfEntry 4 }

ieee8021AsPortDSPortRole OBJECT-TYPE
SYNTAX INTEGER {
disabledPort(3),
masterPort(6),
passivePort(7),
slavePort(9)
}
MAX-ACCESS read-only
STATUS current
DESCRIPTION "The value is the value of the port role of this port (see Table 10-1), and is taken from the enumeration in Table 14-5. All other values reserved. The enumeration values are consistent with IEEE Std 1588TM-2008, Table 8. The default value is 3 (DisabledPort)."

REFERENCE "14.6.3"
DEFVAL { 3 }
 ::= { ieee8021AsPortDSIfEntry 5 }

```

ieee8021AsPortDSPttPortEnabled OBJECT-TYPE
    SYNTAX      TruthValue
    MAX-ACCESS  read-write
    STATUS      current
    DESCRIPTION
        "802.1AS function enable for a given port. True (1) if
        the time-synchronization and best master selection
        functions of the port are enabled;
        False (2) otherwise (see 10.2.4.12).

        The contents of this table SHALL be maintained across a
        restart          of the system.

        "
    REFERENCE   "14.6.4"
    DEFVAL { 1 }
    ::= { ieee8021AsPortDSIfEntry 6 }

ieee8021AsPortDSIsMeasuringDelay OBJECT-TYPE
    SYNTAX      TruthValue
    MAX-ACCESS  read-only
    STATUS      current
    DESCRIPTION
        "True (1) if the port is measuring link propagation delay;
        The value is equal to the value of the Boolean
        isMeasuringPdDelay (see 11.2.12.5 and E.4.3.2)
        False (2) otherwise."
    REFERENCE   "14.6.5"
    DEFVAL { 2 }
    ::= { ieee8021AsPortDSIfEntry 7 }

ieee8021AsPortDSAsCapable OBJECT-TYPE
    SYNTAX      TruthValue
    MAX-ACCESS  read-only
    STATUS      current
    DESCRIPTION
        "True (1) if and only if it is determined that this
        time-aware system and the time-aware system at the
        other ends of the link attached to this port can
        interoperate with each other via the IEEE 802.1AS
        protocol; False (2) otherwise."
    REFERENCE   "14.6.6"
    ::= { ieee8021AsPortDSIfEntry 8 }

ieee8021AsPortDSNeighborPropDelayHs OBJECT-TYPE
    SYNTAX      Unsigned32
    UNITS       "2** $-16$  ns * 2** $64$ "
    MAX-ACCESS  read-only
    STATUS      current
    DESCRIPTION
        "The most (highest) significant 32 bits, unsigned

```

96 bit number in 2^{*-16} ns, the value is equal to the value of the per-port global variable `neighborPropDelay` (see 10.2.4.6). It is an estimate of the current one-way propagation time on the link attached to this port, measured as specified for the respective medium (see 11.2.15, 12.5, and E.4). The value is zero for ports attached to IEEE 802.3 EPON links and for the master port of an IEEE 802.11 link, because one-way propagation delay is not measured on the latter and not directly measured on the former. It is recommended that the data type be scaled in ns. The initialization value is zero.

This object MUST be read at the same time as `ieee8021AsPortDSNeighborPropDelayMs`, and `ieee8021AsPortDSNeighborPropDelayLs`, which represents middle and least significant 32 bits of values, respectively, in order for the read operation to succeed.

"

REFERENCE "14.6.7"
 DEFVAL { 0 }
 ::= { ieee8021AsPortDSIfEntry 9 }

`ieee8021AsPortDSNeighborPropDelayMs` OBJECT-TYPE

SYNTAX Unsigned32
 UNITS "2^{*-16} ns * 2^{*32}"
 MAX-ACCESS read-only
 STATUS current
 DESCRIPTION

"The second most (middle) significant 32 bits, unsigned 96 bit number in 2^{*-16} ns, the value is equal to the value of the per-port global variable `neighborPropDelay` (see 10.2.4.6). It is an estimate of the current one-way propagation time on the link attached to this port, measured as specified for the respective medium (see 11.2.15, 12.5, and E.4). The value is zero for ports attached to IEEE 802.3 EPON links and for the master port of an IEEE 802.11 link, because one-way propagation delay is not measured on the latter and not directly measured on the former. It is recommended that the data type be scaled in ns. The initialization value is zero.

This object MUST be read at the same time as `ieee8021AsPortDSNeighborPropDelayHs`, and `ieee8021AsPortDSNeighborPropDelayLs`, which represents most (highest) and least significant 32 bits of values, respectively, in order for the read operation to succeed.

"

REFERENCE "14.6.7"
 DEFVAL { 0 }
 ::= { ieee8021AsPortDSIfEntry 10 }

```

ieee8021AsPortDSNeighborPropDelayLs OBJECT-TYPE
    SYNTAX      Unsigned32
    UNITS       "2**-16 ns"
    MAX-ACCESS  read-only
    STATUS      current
    DESCRIPTION
        "The least significant 32 bits, unsigned
        96 bit number in 2**-16 ns, the value is equal to the
        value of the per-port global variable
        neighborPropDelay (see 10.2.4.6). It is an
        estimate of the current one-way propagation time on the
        link attached to this port, measured as specified for
        the respective medium (see 11.2.15, 12.5, and E.4).
        The value is zero for ports attached to IEEE 802.3 EPON
        links and for the master port of an IEEE 802.11 link,
        because one-way propagation delay is not measured on
        the latter and not directly measured on the former. It
        is recommended that the data type be scaled in ns. The
        initialization value is zero.

        This object MUST be read at the same time as
        ieee8021AsPortDSNeighborPropDelayHs, and
        ieee8021AsPortDSNeighborPropDelayMs, which
        represents most (highest) and middle significant 32 bits
        of values, respectively, in order for the read operation
        to succeed.
        "
    REFERENCE   "14.6.7"
    DEFVAL { 0 }
    ::= { ieee8021AsPortDSIfEntry 11 }

```

```

ieee8021AsPortDSNeighborPropDelayThreshHs OBJECT-TYPE
    SYNTAX      Unsigned32
    UNITS       "2**-16 ns * 2 ** 64"
    MAX-ACCESS  read-write
    STATUS      current
    DESCRIPTION
        "The most (highest) significant 32 bits, unsigned
        96 bit number in 2**-16 ns, the value is equal to the
        value of the per-port global variable
        neighborPropDelayThresh (see 11.2.12.5). It
        is the propagation time threshold, above which a port
        is not considered capable of participating in the
        802.1AS protocol

        This object MUST be read or written at the same time as
        ieee8021AsPortDSNeighborPropDelayThreshMs, and
        ieee8021AsPortDSNeighborPropDelayThreshLs, which
        represents middle and least significant 32 bits
        of values, respectively, in order for the read or write
        operation to succeed.

```

The contents of this variable SHALL be maintained across a restart of the system.

"

REFERENCE "14.6.8"
 ::= { ieee8021AsPortDSIfEntry 12 }

ieee8021AsPortDSNeighborPropDelayThreshMs OBJECT-TYPE

SYNTAX Unsigned32
UNITS "2** -16 ns * 2 ** 32"
MAX-ACCESS read-write
STATUS current
DESCRIPTION

"The middle significant 32 bits, unsigned 96 bit number in 2** -16 ns, the value is equal to the value of the per-port global variable neighborPropDelayThresh (see 11.2.12.5). It is the propagation time threshold, above which a port is not considered capable of participating in the 802.1AS protocol

This object MUST be read or written at the same time as ieee8021AsPortDSNeighborPropDelayThreshHs, and ieee8021AsPortDSNeighborPropDelayThreshLs, which represents most (highest) and least significant 32 bits of values, respectively, in order for the read or write operation to succeed.

The contents of this variable SHALL be maintained across a restart of the system.

"

REFERENCE "14.6.8"
 ::= { ieee8021AsPortDSIfEntry 13 }

ieee8021AsPortDSNeighborPropDelayThreshLs OBJECT-TYPE

SYNTAX Unsigned32
UNITS "2** -16 ns"
MAX-ACCESS read-write
STATUS current
DESCRIPTION

"The least significant 32 bits, unsigned 96 bit number in 2** -16 ns, the value is equal to the value of the per-port global variable neighborPropDelayThresh (see 11.2.12.5). It is the propagation time threshold, above which a port is not considered capable of participating in the 802.1AS protocol

This object MUST be read at the same time as ieee8021AsPortDSNeighborPropDelayThreshHs, and ieee8021AsPortDSNeighborPropDelayThreshMs, which represents most (highest) and middle significant 32 bits of values, respectively, in order for the read or write operation to succeed.

The contents of this variable SHALL be maintained across a restart of the system.

"

REFERENCE "14.6.8"
 ::= { ieee8021AsPortDSIfEntry 14 }

ieee8021AsPortDSDelayAsymmetryHs OBJECT-TYPE

SYNTAX Integer32
UNITS "2**⁻¹⁶ ns * 2**⁶⁴"
MAX-ACCESS read-write
STATUS current
DESCRIPTION

"The most (highest) significant 32 bits, signed 96 bit number in 2**⁻¹⁶ ns.
The value is the asymmetry in the propagation delay on the link attached to this port relative to the grandmaster time base, as defined in 8.3. If propagation delay asymmetry is not modeled, then delayAsymmetry is 0.

This object MUST be read or written at the same time as ieee8021AsPortDSDelayAsymmetryMs, and ieee8021AsPortDSDelayAsymmetryLs, which represents middle and least significant 32 bits of values, respectively, in order for the read or write operation to succeed.

The contents of this variable SHALL be maintained across a restart of the system.

"

REFERENCE "14.6.9 and 8.3"
 ::= { ieee8021AsPortDSIfEntry 15 }

ieee8021AsPortDSDelayAsymmetryMs OBJECT-TYPE

SYNTAX Unsigned32
UNITS "2**⁻¹⁶ ns * 2**³²"
MAX-ACCESS read-write
STATUS current
DESCRIPTION

"The middle significant 32 bits, signed 96 bit number in 2**⁻¹⁶ ns.
The value is the asymmetry in the propagation delay on the link attached to this port relative to the grandmaster time base, as defined in 8.3. If propagation delay asymmetry is not modeled, then delayAsymmetry is 0.

This object MUST be read or written at the same time as ieee8021AsPortDSDelayAsymmetryHs, and ieee8021AsPortDSDelayAsymmetryLs, which represents middle and least significant 32 bits of values, respectively, in order for the read or write operation to succeed.

The contents of this variable SHALL be maintained across a restart of the system.

"

REFERENCE "14.6.9 and 8.3"
 ::= { ieee8021AsPortDSIfEntry 16 }

ieee8021AsPortDSDelayAsymmetryLs OBJECT-TYPE

SYNTAX Unsigned32
UNITS "2**⁻¹⁶ ns"
MAX-ACCESS read-write
STATUS current
DESCRIPTION

"The least significant 32 bits, signed 96 bit number in 2**⁻¹⁶ ns. The value is the asymmetry in the propagation delay on the link attached to this port relative to the grandmaster time base, as defined in 8.3. If propagation delay asymmetry is not modeled, then delayAsymmetry is 0.

This object MUST be read or written at the same time as ieee8021AsPortDSDelayAsymmetryHs, and ieee8021AsPortDSDelayAsymmetryLs, which represents most (highest) and least significant 32 bits of values, respectively, in order for the read or write operation to succeed.

The contents of this variable SHALL be maintained across a restart of the system.

"

REFERENCE "14.6.9 and 8.3"
 ::= { ieee8021AsPortDSIfEntry 17 }

ieee8021AsPortDSNeighborRateRatio OBJECT-TYPE

SYNTAX Integer32
MAX-ACCESS read-only
STATUS current
DESCRIPTION

"The value is an estimate of the ratio of the frequency of the LocalClock entity of the time-aware system at the other end of the link attached to this port, to the frequency of the LocalClock entity of this time-aware system (see 10.2.4.6). Neighbor rate ratio is expressed as the fractional frequency offset multiplied by 2**⁴¹, i.e., the quantity (neighborRateRatio - 1.0) (2**⁴¹)."

REFERENCE "14.6.10"
 ::= { ieee8021AsPortDSIfEntry 18 }

ieee8021AsPortDSInitialLogAnnounceInterval OBJECT-TYPE

SYNTAX Integer32 (-128..127)
MAX-ACCESS read-write
STATUS current

DESCRIPTION

"The value is the logarithm to the base 2 of the of the announce interval used when
 (a) the port is initialized, or
 (b) a message interval request TLV is received with announceInterval field set to 126 (see 10.6.2.2 and and the AnnounceIntervalSetting state machine 10.3.14)
 The default value is 0.

The contents of this variable SHALL be maintained across a restart of the system.

"

REFERENCE "14.6.11"
 DEFVAL { 0 }
 ::= { ieee8021AsPortDSIfEntry 19 }

ieee8021AsPortDSCurrentLogAnnounceInterval OBJECT-TYPE

SYNTAX Integer32(-128..127)
 MAX-ACCESS read-only
 STATUS current
 DESCRIPTION

"The value is the logarithm to the base 2 of the of the current announce transmission interval.

The currentLogAnnounceInterval specifies the current value of the announce interval.
 Every port supports the value 127; the port does not send Announce messages when currentLogAnnounceInterval has this value (see 10.3.14). A port may support other values, except for the reserved values -128 through -125, inclusive, and 124 through 126, inclusive. A port ignores requests (see 10.3.14) for unsupported values.

"

REFERENCE "14.6.12"
 ::= { ieee8021AsPortDSIfEntry 20 }

ieee8021AsPortDSAnnounceReceiptTimeout OBJECT-TYPE

SYNTAX Unsigned32(0..255)
 MAX-ACCESS read-write
 STATUS current
 DESCRIPTION

"The value of this attribute tells a slave port the number of sync intervals to wait without receiving synchronization information, before assuming that the master is no longer transmitting synchronization information, and that the BMC algorithm needs to be run, if appropriate. The condition of the slave port not receiving synchronization information for syncReceiptTimeout sync intervals is referred to as 'sync receipt timeout'.

The default value is 2 (see 10.6.3.2).

The contents of this variable SHALL be maintained across a restart of the system.

"

REFERENCE "14.6.13"
DEFVAL { 2 }
::= { ieee8021AsPortDSIfEntry 21 }

ieee8021AsPortDSInitialLogSyncInterval OBJECT-TYPE

SYNTAX Integer32(-128..127)

MAX-ACCESS read-write

STATUS current

DESCRIPTION

"The value is the logarithm to the base 2 of the sync interval used when,
(a) the port is initialized, or
(b) a message interval request TLV is received with the timeSyncInterval field set to 126 (see 10.6.2.3, 11.5.2.3, 12.6.2, 13.9.2, and the LinkDelaySyncIntervalSetting state machine, 11.2.17).

The initialization value is -3 (see 10.6.2.3).

The contents of this variable SHALL be maintained across a restart of the system.

"

REFERENCE "14.6.14"
DEFVAL { -3 }
::= { ieee8021AsPortDSIfEntry 22 }

ieee8021AsPortDSCurrentLogSyncInterval OBJECT-TYPE

SYNTAX Integer32(-128..127)

MAX-ACCESS read-only

STATUS current

DESCRIPTION

"The value is the logarithm to the base 2 of the current time-synchronization transmission interval, see 10.6.2.3.

The initialization value is -3.

"

REFERENCE "14.6.15"
DEFVAL { -3 }
::= { ieee8021AsPortDSIfEntry 23 }

ieee8021AsPortDSSyncReceiptTimeout OBJECT-TYPE

SYNTAX Unsigned32(0..255)

MAX-ACCESS read-write

STATUS current

DESCRIPTION

"The value is the number of time-synchronization transmission intervals that a slave port waits without

receiving synchronization information, before assuming that the master is no longer transmitting synchronization information and that the BMCA needs to be run, if appropriate.
The initialization value is 3 (see 10.6.3.1).

The contents of this variable SHALL be maintained across a restart of the system.

```
"
REFERENCE "14.6.16"
DEFVAL { 3 }
::= { ieee8021AsPortDSIfEntry 24 }
```

ieee8021AsPortDSSyncReceiptTimeoutTimeIntervalHs OBJECT-TYPE

```
SYNTAX      Unsigned32
UNITS       "2** $-16$  ns"
MAX-ACCESS  read-only
STATUS      current
DESCRIPTION
```

"The most (highest) significant 32 bits, of unsigned 96 bit number in 2^{*-16} ns.
The value is equal to the value of the per port global variable syncReceiptTimeoutTimeInterval (see 10.2.4.2). It is the time interval after which sync receipt timeout occurs if time-synchronization information has not been received during the interval.

This object MUST be read at the same time as ieee8021AsPortDSSyncReceiptTimeoutTimeIntervalMs, and ieee8021AsPortDSSyncReceiptTimeoutTimeIntervalLs, which represents middle and least significant 32 bits of values, respectively, in order for the read operation to succeed.

Default value is calculated per 10.2.4.2, or '0000 0000 0000 165A 0BC0 0000'h.

The contents of this variable SHALL be maintained across a restart of the system.

```
"
REFERENCE "14.6.17"
DEFVAL { '00000000'h }
::= { ieee8021AsPortDSIfEntry 25 }
```

ieee8021AsPortDSSyncReceiptTimeoutTimeIntervalMs OBJECT-TYPE

```
SYNTAX      Unsigned32
UNITS       "2** $-16$  ns * 2**32"
MAX-ACCESS  read-only
STATUS      current
DESCRIPTION
```

"The middle significant 32 bits, unsigned 96 bit number in 2^{*-16} ns.
The value is equal to the value of the per port global

variable `syncReceiptTimeoutTimeInterval` (see 10.2.4.2). It is the time interval after which sync receipt timeout occurs if time-synchronization information has not been received during the interval.

This object MUST be read at the same time as `ieee8021AsPortDSSyncReceiptTimeoutTimeIntervalHs`, and `ieee8021AsPortDSSyncReceiptTimeoutTimeIntervalLs`, which represents most (highest) and least significant 32 bits of values, respectively, in order for the read operation to succeed.

Default value is calculated per 10.2.4.2, or '0000 0000 0000 165A 0BC0 0000'h.

The contents of this variable SHALL be maintained across a restart of the system.

"

```
REFERENCE    "14.6.17"  
DEFVAL { '0000165A'h }  
::= { ieee8021AsPortDSIfEntry 26 }
```

`ieee8021AsPortDSSyncReceiptTimeoutTimeIntervalLs` OBJECT-TYPE

```
SYNTAX      Unsigned32  
UNITS       "2**-16 ns"  
MAX-ACCESS  read-only  
STATUS      current  
DESCRIPTION
```

"The least significant 32 bits, unsigned 96 bit number in 2**⁻¹⁶ ns. The value is equal to the value of the per port global variable `syncReceiptTimeoutTimeInterval` (see 10.2.4.2). It is the time interval after which sync receipt timeout occurs if time-synchronization information has not been received during the interval.

This object MUST be read at the same time as `ieee8021AsPortDSSyncReceiptTimeoutTimeIntervalHs`, and `ieee8021AsPortDSSyncReceiptTimeoutTimeIntervalMs`, which represents most (highest) and middle significant 32 bits of values, respectively, in order for the read operation to succeed.

Default value is calculated per 10.2.4.2, or '0000 0000 0000 165A 0BC0 0000'h.

The contents of this variable SHALL be maintained across a restart of the system.

"

```
REFERENCE    "14.6.17"  
DEFVAL { '0BC00000'h }  
::= { ieee8021AsPortDSIfEntry 27 }
```

```

ieee8021AsPortDSInitialLogPdelayReqInterval OBJECT-TYPE
    SYNTAX      Integer32(-128..127)
    MAX-ACCESS  read-write
    STATUS      current
    DESCRIPTION
        "For full-duplex, IEEE 802.3 media and CSN media that use
        the peer delay mechanism to measure path delay (see
        E.4.3.1), the value is the logarithm to the base 2 of the
        Pdelay_Req message transmission interval used when,
        (a) the port is initialized, or
        (b) a message interval request TLV is received with the
            linkDelayInterval field set to 126 (see 11.5.2.2 and
            the LinkDelaySyncIntervalSetting state machine,
            11.2.17).

        For these media, the initialization value is 0.
        For all other media, the value is 127.

        The contents of this variable SHALL be maintained
        across a restart of the system.

        "
    REFERENCE  "14.6.18"
    ::= { ieee8021AsPortDSIfEntry 28 }

```

```

ieee8021AsPortDSCurrentLogPdelayReqInterval OBJECT-TYPE
    SYNTAX      Integer32(-128..127)
    MAX-ACCESS  read-only
    STATUS      current
    DESCRIPTION
        "For full-duplex, IEEE 802.3 media and CSN media that use
        the peer delay mechanism to measure path delay (see
        E.4.3.1), the value is the logarithm to the base 2 of the
        current Pdelay_Req message transmission interval,
        see 11.5.2.2.

        For all other media, the value is 127.

        The contents of this variable SHALL be maintained
        across a restart of the system.

        "
    REFERENCE  "14.6.19"
    ::= { ieee8021AsPortDSIfEntry 29 }

```

```

ieee8021AsPortDSAllowedLostResponses OBJECT-TYPE
    SYNTAX      Unsigned32(0..65535)
    MAX-ACCESS  read-write
    STATUS      current
    DESCRIPTION
        "The value is equal to the value of the per-port global
        variable allowedLostResponses (see 11.2.12.4). It is
        the number of Pdelay_Req messages for which a valid
        response is not received, above which a port is
        considered to not be exchanging peer delay messages

```

with its neighbor.

```
"  
REFERENCE "14.6.20 and 11.5.3"  
DEFVAL { 3 }  
::= { ieee8021AsPortDSIfEntry 30 }
```

ieee8021AsPortDSVersionNumber OBJECT-TYPE

```
SYNTAX      Unsigned32(0..63)  
MAX-ACCESS  read-only  
STATUS      current  
DESCRIPTION  
            "Indicates the PTP version in use on the port.  
            The version number for this standard is set to  
            the value 2 (see 10.5.2.2.3).  
  
            The contents of this variable SHALL be maintained  
            across a restart of the system.
```

```
"  
REFERENCE "14.6.21"  
DEFVAL { 2 }  
::= { ieee8021AsPortDSIfEntry 31 }
```

ieee8021AsPortDSNupMs OBJECT-TYPE

```
SYNTAX      Unsigned32  
MAX-ACCESS  read-write  
STATUS      current  
DESCRIPTION  
            "The most significant 32 bits, of unsigned  
            64 bit fixed point number between 0 and less than 2.  
            For an OLT port of an IEEE 802.3 EPON link, the value is  
            the effective index of refraction for the EPON upstream  
            wavelength light of the optical path (see 13.1.4 and  
            13.8.1.2). The default value is  
            1.46770 for 1 Gb/s upstream links, and  
            1.46773 for 10 Gb/s upstream links.  
            For all other ports, the value is 0.  
  
            This object MUST be read or written at the same time as  
            ieee8021AsPortDSNupLs, which represents least  
            significant 32 bits of the value in order for the read  
            or write operation to succeed.
```

```
            The contents of this variable SHALL be maintained  
            across a restart of the system.
```

```
"  
REFERENCE "14.6.22"  
::= { ieee8021AsPortDSIfEntry 32 }
```

ieee8021AsPortDSNupLs OBJECT-TYPE

```
SYNTAX      Unsigned32  
MAX-ACCESS  read-write
```



```

STATUS      current
DESCRIPTION
    "The least significant 32 bits, of unsigned
    64 bit fixed point number between 0 and less than 2.
    For an OLT port of an IEEE 802.3 EPON link, the value is
    the effective index of refraction for the EPON upstream
    wavelength light of the optical path (see 13.1.4 and
    13.8.1.2). The default value is
    1.46770 for 1 Gb/s upstream links, and
    1.46773 for 10 Gb/s upstream links.

    For all other ports, the value is 0.

    This object MUST be read or written at the same time as
    ieee8021AsPortDSNupMs, which represents the most
    significant 32 bits of the value in order for the read
    or write operation to succeed.

    The contents of this variable SHALL be maintained
    across a restart of the system.
    "
REFERENCE   "14.6.22"
 ::= { ieee8021AsPortDSIfEntry 33 }

```

```

ieee8021AsPortDSNdownMs OBJECT-TYPE
SYNTAX      Unsigned32
MAX-ACCESS  read-write
STATUS      current
DESCRIPTION
    "The least significant 32 bits, of unsigned
    64 bit fixed point number between 0 and less than 2.
    For an OLT port of an IEEE 802.3 EPON link, the value is
    the effective index of refraction for the EPON
    downstream wavelength light of the optical path (see
    13.1.4 and 13.8.1.2.2). The default value is
    1.46805 for 1 Gb/s downstream links, and
    1.46851 for 10 Gb/s downstream links.

    For all other ports, the value is 0.

    This object MUST be read or written at the same time as
    ieee8021AsPortDSNdownLs, which represents the least
    significant 32 bits of the value in order for the read
    or write operation to succeed.

    The contents of this variable SHALL be maintained
    across a restart of the system.
    "
REFERENCE   "14.6.23"
 ::= { ieee8021AsPortDSIfEntry 34 }

```

```

ieee8021AsPortDSNdownLs OBJECT-TYPE
SYNTAX      Unsigned32
MAX-ACCESS  read-write

```

STATUS current
DESCRIPTION

"The least significant 32 bits, of unsigned 64 bit fixed point number between 0 and less than 2. For an OLT port of an IEEE 802.3 EPON link, the value is the effective index of refraction for the EPON downstream wavelength light of the optical path (see 13.1.4 and 13.8.1.2.1). The default value is 1.46805 for 1 Gb/s downstream links, and 1.46851 for 10 Gb/s downstream links.

For all other ports, the value is 0.

This object MUST be read or written at the same time as ieee8021AsPortDSNdownMs, which represents the most significant 32 bits of the value in order for the read or write operation to succeed.

The contents of this variable SHALL be maintained across a restart of the system.

"

REFERENCE "14.6.23"
::= { ieee8021AsPortDSIfEntry 35 }

ieee8021AsPortDSAcceptableMasterTableEnabled OBJECT-TYPE

SYNTAX TruthValue
MAX-ACCESS read-write
STATUS current
DESCRIPTION

"True (1) if acceptableMasterTableEnabled (see 13.1.3.1) and 13.1.3.5) is true and an ONU port attached to an IEEE 802.3 EPON link in a time-aware system.

False (2), otherwise.
The default value is FALSE.

The contents of this variable SHALL be maintained across a restart of the system.

"

REFERENCE "14.6.24"
DEFVAL { false }
::= { ieee8021AsPortDSIfEntry 36 }

-- =====
-- The Statistics for each .1AS capable port.
-- One Table per Bridge Component or a end station.
-- One entry per port.
-- =====

ieee8021AsPortStatIfTable OBJECT-TYPE

SYNTAX SEQUENCE OF Ieee8021AsPortStatIfEntry
MAX-ACCESS not-accessible
STATUS current

DESCRIPTION

"A table of time-aware port related counters in a gPTP domain.
A value of 1 is used in a bridge or an end station that does not
have multiple components.

"

REFERENCE

"IEEE 802.1AS clause 14.7"

::= { ieee8021AsMIBObjects 6 }

ieee8021AsPortStatIfEntry OBJECT-TYPE

SYNTAX Ieee8021AsPortStatIfEntry

MAX-ACCESS not-accessible

STATUS current

DESCRIPTION

"A list of statistics pertaining to a port of a gPTP domain.
This statistics table uses ieee8021AsPortDSAsIfIndex, and
corresponds to ieee8021ASPortDSTable entries.

"

INDEX { ieee8021AsBridgeBasePort,
 ieee8021AsPortDSAsIfIndex }

::= { ieee8021AsPortStatIfTable 1 }

Ieee8021AsPortStatIfEntry ::=

SEQUENCE {

ieee8021AsPortStatRxSyncCount	Counter32,
ieee8021AsPortStatRxFollowUpCount	Counter32,
ieee8021AsPortStatRxPdelayRequest	Counter32,
ieee8021AsPortStatRxPdelayResponse	Counter32,
ieee8021AsPortStatRxPdelayResponseFollowUp	Counter32,
ieee8021AsPortStatRxAnnounce	Counter32,
ieee8021AsPortStatRxPTPPacketDiscard	Counter32,
ieee8021AsPortStatRxSyncReceiptTimeouts	Counter32,
ieee8021AsPortStatAnnounceReceiptTimeouts	Counter32,
ieee8021AsPortStatPdelayAllowedLostResponsesExceeded	Counter32,
ieee8021AsPortStatTxSyncCount	Counter32,
ieee8021AsPortStatTxFollowUpCount	Counter32,
ieee8021AsPortStatTxPdelayRequest	Counter32,
ieee8021AsPortStatTxPdelayResponse	Counter32,
ieee8021AsPortStatTxPdelayResponseFollowUp	Counter32,
ieee8021AsPortStatTxAnnounce	Counter32

}

ieee8021AsPortStatRxSyncCount OBJECT-TYPE

SYNTAX Counter32

MAX-ACCESS read-only

STATUS current

DESCRIPTION

"A counter that increments every time synchronization
information is received, denoted by a transition to
TRUE from FALSE of the rcvdSync variable of the
MDSyncReceiveSM state machine (see 11.2.13.1.2 and
Figure 11-6), when in the DISCARD or WAITING_FOR_SYNC
states; or rcvdIndication transitions to TRUE (see

Figure 12-4).

"

REFERENCE "14.7.2"
 ::= { ieee8021AsPortStatIfEntry 1 }

ieee8021AsPortStatRxFollowUpCount OBJECT-TYPE

SYNTAX Counter32
MAX-ACCESS read-only
STATUS current
DESCRIPTION

"A counter that increments every time a Follow_Up message is received, denoted by a transition to TRUE from FALSE of the rcvdFollowUp variable of the MDSyncReceiveSM state machine (see 11.2.13.1.3 and Figure 11-6) when in the WAITING_FOR_FOLLOW_UP state.

"

REFERENCE "14.7.3"
 ::= { ieee8021AsPortStatIfEntry 2 }

ieee8021AsPortStatRxDelayRequest OBJECT-TYPE

SYNTAX Counter32
MAX-ACCESS read-only
STATUS current
DESCRIPTION

"A counter that increments every time a Pdelay_Req message is received, denoted by a transition to TRUE from FALSE of the rcvdPdelayReq variable of the MDPdelayResp state machine (see 11.2.16.1.1 and Figure 11-9) when in the WAITING_FOR_PDELAY_REQ or INITIAL_WAITING_FOR_PDELAY_REQ states.

"

REFERENCE "14.7.4"
 ::= { ieee8021AsPortStatIfEntry 3 }

ieee8021AsPortStatRxDelayResponse OBJECT-TYPE

SYNTAX Counter32
MAX-ACCESS read-only
STATUS current
DESCRIPTION

"A counter that increments every time a Pdelay_Resp message is received, denoted by a transition to TRUE from FALSE of the rcvdPdelayResp variable of the MDPdelayReq state machine (see 11.2.15.1.2 and Figure 11-8) when in the WAITING_FOR_PDELAY_RESP state.

"

REFERENCE "14.7.5"
 ::= { ieee8021AsPortStatIfEntry 4 }

ieee8021AsPortStatRxDelayResponseFollowUp OBJECT-TYPE

SYNTAX Counter32
MAX-ACCESS read-only
STATUS current
DESCRIPTION

"A counter that increments every time a

Pdelay_Resp_Follow_Up message is received, denoted by a transition to TRUE from FALSE of the rcvdPdelayRespFollowUp variable of the MDPdelayReq state machine (see 11.2.15.1.4 and Figure 11-8) when in the WAITING_FOR_PDELAY_RESP_FOLLOW_UP state.

REFERENCE "14.7.6"
 ::= { ieee8021AsPortStatIfEntry 5 }

ieee8021AsPortStatRxAnnounce OBJECT-TYPE

SYNTAX Counter32
MAX-ACCESS read-only
STATUS current
DESCRIPTION

"A counter that increments every time an Announce message is received, denoted by a transition to TRUE from FALSE of the rcvdAnnounce variable of the PortAnnounceReceive state machine (see 10.3.10 and Figure 10-12) when in the DISCARD or RECEIVE states.

REFERENCE "14.7.7"
 ::= { ieee8021AsPortStatIfEntry 6 }

ieee8021AsPortStatRxPTPPacketDiscard OBJECT-TYPE

SYNTAX Counter32
MAX-ACCESS read-only
STATUS current
DESCRIPTION

"A counter that increments every time a PTP message is discarded, caused by the occurrence of any of the following conditions:

- a) A received Announce message is not qualified, denoted by the function qualifyAnnounce (see 10.3.10.2.1 and 13.1.3.4) of the PortAnnounceReceive state machine (see 10.3.10 and Figure 10-12) returning FALSE;
- b) A Follow_Up message corresponding to a received Sync message is not received, denoted by a transition of the condition (currentTime greater or equal to followUpReceiptTimeoutTime) to TRUE from FALSE when in the WAITING_FOR_FOLLOW_UP state of the MDSyncReceiveSM state machine (see 11.2.13 and Figure 11-6);
- c) A Pdelay_Resp message corresponding to a transmitted Pdelay_Req message is not received, denoted by a transition from the WAITING_FOR_PDELAY_RESP state to the RESET state of the MDPdelayReq state machine (see 11.2.15 and Figure 11-8);
- d) A Pdelay_Resp_Follow_Up message corresponding to a transmitted Pdelay_Req message is not received, denoted by a transition from the WAITING_FOR_PDELAY_RESP_FOLLOW_UP state to the

RESET state of the MDPdelayReq state machine (see 11.2.15 and Figure 11-8).

"

REFERENCE "14.7.8"
 ::= { ieee8021AsPortStatIfEntry 7 }

ieee8021AsPortStatRxSyncReceiptTimeouts OBJECT-TYPE

SYNTAX Counter32
MAX-ACCESS read-only
STATUS current
DESCRIPTION

"A counter that increments every time sync receipt timeout occurs, denoted by entering the AGED state of the PortAnnounceInformation state machine (see 10.3.11 and Figure 10-13), with the condition (currentTime greater or equal to announceReceiptTimeoutTime) TRUE

"

REFERENCE "14.7.9"
 ::= { ieee8021AsPortStatIfEntry 8 }

ieee8021AsPortStatAnnounceReceiptTimeouts OBJECT-TYPE

SYNTAX Counter32
MAX-ACCESS read-only
STATUS current
DESCRIPTION

"A counter that increments every time announce receipt timeout occurs, denoted by entering the AGED state of the PortAnnounceInformation state machine (see 10.3.11 and Figure 10-13), with the condition ((currentTime greater than or equal to syncReceiptTimeoutTime) AND gmPresent)) TRUE.

"

REFERENCE "14.7.10"
 ::= { ieee8021AsPortStatIfEntry 9 }

ieee8021AsPortStatPdelayAllowedLostResponsesExceeded OBJECT-TYPE

SYNTAX Counter32
MAX-ACCESS read-only
STATUS current
DESCRIPTION

"A counter that increments everytime the value of the variable lostResponses (see, 11.2.15.1.10) exceeds the value of the variable allowedLostResponses (see 11.2.12.4), in the RESET state of the MDPdelayReq state machine (see 11.2.15 and Figure 11-8)

"

REFERENCE "14.7.11"
 ::= { ieee8021AsPortStatIfEntry 10 }

ieee8021AsPortStatTxSyncCount OBJECT-TYPE

SYNTAX Counter32
MAX-ACCESS read-only
STATUS current
DESCRIPTION

"A counter that increments every time synchronization information is transmitted, denoted by a transition to TRUE from FALSE of the rcvdMDSync variable of the MDSyncSendSM state machine (see 11.2.14.1.1 and Figure 11-7), when in the INITIALIZING or SEND_FOLLOW_UP states; or the INITIATE_REQUEST_WAIT_CONFIRM state is entered in Figure 12-3.

REFERENCE "14.7.12"
 ::= { ieee8021AsPortStatIfEntry 11 }

ieee8021AsPortStatTxFollowUpCount OBJECT-TYPE

SYNTAX Counter32
 MAX-ACCESS read-only
 STATUS current
 DESCRIPTION

"A counter that increments every time a Follow_Up message is transmitted, denoted by a transition to TRUE from FALSE of the rcvdMDTimestampReceive variable of the MDSyncSendSM state machine (see 11.2.14.1.3 and Figure 11-7), when in the SEND_SYNC state increments every time a Follow_Up packet is transmitted.

REFERENCE "14.7.13"
 ::= { ieee8021AsPortStatIfEntry 12 }

ieee8021AsPortStatTxPdelayRequest OBJECT-TYPE

SYNTAX Counter32
 MAX-ACCESS read-only
 STATUS current
 DESCRIPTION

"A counter that increments every time a Pdelay_Req message is transmitted, denoted by entering the INITIAL_SEND_PDELAY_REQ or SEND_PDELAY_REQ states of the MDPdelayReq state machine (see 11.2.15 and Figure 11-8).

REFERENCE "14.7.14"
 ::= { ieee8021AsPortStatIfEntry 13 }

ieee8021AsPortStatTxPdelayResponse OBJECT-TYPE

SYNTAX Counter32
 MAX-ACCESS read-only
 STATUS current
 DESCRIPTION

"A counter that increments every time a Pdelay_Resp message is transmitted, denoted by a transition to TRUE from FALSE of the rcvdPdelayReq variable of the MDPdelayResp state machine (see 11.2.16.1.1 and Figure 11-9) when in the WAITING_FOR_PDELAY_REQ or INITIAL_WAITING_FOR_PDELAY_REQ states, and resulting entry to the SENT_PDELAY_RESP_WAITING_FOR_TIMESTAMP state.

```
REFERENCE    "14.7.15"
 ::= { ieee8021AsPortStatIfEntry 14 }
```

```
ieee8021AsPortStatTxPdelayResponseFollowUp OBJECT-TYPE
```

```
SYNTAX      Counter32
```

```
MAX-ACCESS  read-only
```

```
STATUS      current
```

```
DESCRIPTION
```

```
"A counter that increments every time a
Pdelay_Resp_Follow_Up message is transmitted, denoted
by a transition to TRUE from FALSE of the
rcvdMDTimestampReceive variable of the MDPdelayResp
state machine (see 11.2.16.1.2 and Figure 11-9) when in
the SENT_PDELAY_RESP_WAITING_FOR_TIMESTAMP state, and
resulting entry to the WAITING_FOR_PDELAY_REQ state.
"
```

```
REFERENCE    "14.7.16"
 ::= { ieee8021AsPortStatIfEntry 15 }
```

```
ieee8021AsPortStatTxAnnounce OBJECT-TYPE
```

```
SYNTAX      Counter32
```

```
MAX-ACCESS  read-only
```

```
STATUS      current
```

```
DESCRIPTION
```

```
"A counter that increments every time an Announce message
is transmitted, denoted by entering the
TRANSMIT_ANNOUNCE state of the PortAnnounceReceive state
machine (see 10.3.13 and Figure 10-15).
"
```

```
REFERENCE    "14.7.17"
 ::= { ieee8021AsPortStatIfEntry 16 }
```

```
-- *****
-- Acceptable Master Table derived from IEEE 1588-2008.
-- One Table per time-aware system, and used when any of the system
-- is of type IEEE 802.3 EPON, i.e. if any of port in a corresponding
-- system has ieee8021AsPortDSAcceptableMasterTableEnabled set to true.
-- Not used otherwise (Table exists without an entry).
-- *****
```

```
ieee8021AsAcceptableMasterTableDS
  OBJECT IDENTIFIER ::= { ieee8021AsMIBObjects 7 }
```

```
ieee8021AsAcceptableMasterTableDSBase
  OBJECT IDENTIFIER ::= { ieee8021AsAcceptableMasterTableDS 1 }
```

```
ieee8021AsAcceptableMasterTableDSMaster
  OBJECT IDENTIFIER ::= { ieee8021AsAcceptableMasterTableDS 2 }
```

```
ieee8021AsAcceptableMasterTableDSMaxTableSize OBJECT-TYPE
```

```
SYNTAX      Unsigned32(0..65535)
```

```
MAX-ACCESS  read-only
```



```

STATUS      current
DESCRIPTION
    "The value is the maximum size of the
    AcceptableMasterTable. It is equal to the maxTableSize
    member of the AcceptableMasterTable structure (see
    13.1.3.2)"
REFERENCE   "14.8.1 and 13.1.3.2"
 ::= { ieee8021AsAcceptableMasterTableDSBase 1 }

```

```

ieee8021AsAcceptableMasterTableDSActualTableSize OBJECT-TYPE
SYNTAX      Unsigned32(0..65535)
MAX-ACCESS  read-write
STATUS      current
DESCRIPTION
    "The value is the actual size of the
    AcceptableMasterTable. It is equal to the
    actualTableSize member of the AcceptableMasterTable
    structure (see 13.1.3.2 and 13.1.3.5),
    i.e., the current number of
    elements in the acceptable master array. The actual
    table size is less than or equal to the max table size.

    This value SHOULD be reflect the number of entries in
    the ieee8021AsAcceptableMasterTableDSMasterTable.

    For a time-aware system that contains an ONU attached
    to an IEEE 802.3 EPON link, the initialization value
    is 1. For a time-aware system that does not contain an
    ONU attached to an IEEE 802.3 EPON link, the
    initialization value is 0."
REFERENCE   "14.8.2 and 13.1.3.2"
 ::= { ieee8021AsAcceptableMasterTableDSBase 2 }

```

```

ieee8021AsAcceptableMasterTableDSMasterTable OBJECT-TYPE
SYNTAX      SEQUENCE OF Ieee8021AsAcceptableMasterTableDSMasterEntry
MAX-ACCESS  not-accessible
STATUS      current
DESCRIPTION
    "A table of time-aware port related variables in a time-aware
    bridge or for a time-aware end station. A value of 1 is used in
    a bridge or an end station that does not have multiple
    components.

    The contents of this table SHALL be maintained across a restart
    of the system.
    "
REFERENCE   "IEEE 802.1AS clause 14.8"
 ::= { ieee8021AsAcceptableMasterTableDSMaster 1 }

```

```

ieee8021AsAcceptableMasterTableDSMasterEntry OBJECT-TYPE
SYNTAX      Ieee8021AsAcceptableMasterTableDSMasterEntry

```

```
MAX-ACCESS not-accessible
STATUS current
DESCRIPTION
    "A list of objects pertaining to a port of a time-aware bridge
    component or a time-aware end station.
    "
INDEX { ieee8021AsAcceptableMasterTableDSMasterId }
 ::= { ieee8021AsAcceptableMasterTableDSMasterTable 1 }
```

```
Ieee8021AsAcceptableMasterTableDSMasterEntry ::=
SEQUENCE {
    ieee8021AsAcceptableMasterTableDSMasterId      Unsigned32,
    ieee8021AsAcceptableMasterClockIdentity        ClockIdentity,
    ieee8021AsAcceptableMasterPortNumber          Unsigned32,
    ieee8021AsAcceptableMasterAlternatePriority1   Unsigned32,
    ieee8021AsAcceptableMasterRowStatus           RowStatus
}
```

```
ieee8021AsAcceptableMasterTableDSMasterId OBJECT-TYPE
SYNTAX Unsigned32
MAX-ACCESS not-accessible
STATUS current
DESCRIPTION
    "Acceptable Master row entry index in this
    ieee8021AsAcceptableMasterTableDSMasterEntry applies.
    If the does not contain Media type of EPON, this variable
    (index) MUST be equal to 0."
 ::= { ieee8021AsAcceptableMasterTableDSMasterEntry 1 }
```

```
ieee8021AsAcceptableMasterClockIdentity OBJECT-TYPE
SYNTAX ClockIdentity
MAX-ACCESS read-create
STATUS current
DESCRIPTION
    "Globally unique manufacturer-assigned clock identifier
    for the local clock port. The identifier is based on an
    EUI-64."
REFERENCE "14.8.3"
 ::= { ieee8021AsAcceptableMasterTableDSMasterEntry 2 }
```

```
ieee8021AsAcceptableMasterPortNumber OBJECT-TYPE
SYNTAX Unsigned32(0..65535)
MAX-ACCESS read-create
STATUS current
DESCRIPTION
    "This object represents a Port or aggregated port
    on a bridge component or end-station.
    This object and ieee8021AsAcceptableMasterClockIdentity
    together forms AcceptableMasterDS Port Identity."
REFERENCE "14.8.3"
 ::= { ieee8021AsAcceptableMasterTableDSMasterEntry 3 }
```

```
ieee8021AsAcceptableMasterAlternatePriority1 OBJECT-TYPE
```

```
SYNTAX      Unsigned32(0..255)
MAX-ACCESS  read-create
STATUS      current
DESCRIPTION
    "If the alternatePriority1 member of the AcceptableMaster
    array element that corresponds to the sourcePortIdentity
    of a received Announce message is greater than 0, the
    value of the grandmasterPriority1 field of the Announce
    message is replaced by the value of alternatePriority1
    of this AcceptableMaster array element for use in the
    invocation of BMCA"
REFERENCE   "14.8.3 and 13.1.3.4"
DEFVAL     { 244 }
::= { ieee8021AsAcceptableMasterTableDSMasterEntry 4 }
```

```
ieee8021AsAcceptableMasterRowStatus OBJECT-TYPE
SYNTAX      RowStatus
MAX-ACCESS  read-create
STATUS      current
DESCRIPTION
    "This object indicates the status of an entry, and is used
    to create/delete entries.
    "
REFERENCE   "14.8.3"
::= { ieee8021AsAcceptableMasterTableDSMasterEntry 5 }
```

```
-- *****
-- IEEE 802.1AS MIB Module - Conformance Information
-- *****
```

```
ieee8021AsCompliances OBJECT IDENTIFIER ::= { ieee8021AsConformance 1 }
ieee8021AsGroups      OBJECT IDENTIFIER ::= { ieee8021AsConformance 2 }
```

```
-- *****
-- Units of conformance
-- *****
```

```
ieee8021ASSystemDefaultReqdGroup OBJECT-GROUP
OBJECTS {
    ieee8021AsDefaultDSClockIdentity,
    ieee8021AsDefaultDSNumberPorts,
    ieee8021AsDefaultDSClockClass,
    ieee8021AsDefaultDSClockAccuracy,
    ieee8021AsDefaultDSOffsetScaledLogVariance,
    ieee8021AsDefaultDSPriority1,
    ieee8021AsDefaultDSPriority2,
    ieee8021AsDefaultDSGmCapable,
    ieee8021AsDefaultDSCurrentUTCOffset,
    ieee8021AsDefaultDSCurrentUTCOffsetValid,
    ieee8021AsDefaultDSLeap59,
    ieee8021AsDefaultDSLeap61,
    ieee8021AsDefaultDSTimeTraceable,
```

```
        ieee8021AsDefaultDSFrequencyTraceable,  
        ieee8021AsDefaultDSTimeSource  
    }  
    STATUS          current  
    DESCRIPTION  
        "Objects in the System Default required global group."  
    ::= { ieee8021AsGroups 1 }  
  
ieee8021AsSystemCurrentGroup OBJECT-GROUP  
    OBJECTS {  
        ieee8021AsCurrentDSStepsRemoved,  
        ieee8021AsCurrentDSOffsetFromMasterHs,  
        ieee8021AsCurrentDSOffsetFromMasterMs,  
        ieee8021AsCurrentDSOffsetFromMasterLs,  
        ieee8021AsCurrentDSLlastGmPhaseChangeHs,  
        ieee8021AsCurrentDSLlastGmPhaseChangeMs,  
        ieee8021AsCurrentDSLlastGmPhaseChangeLs,  
        ieee8021AsCurrentDSLlastGmFreqChangeMs,  
        ieee8021AsCurrentDSLlastGmFreqChangeLs,  
        ieee8021AsCurrentDSGmTimebaseIndicator,  
        ieee8021AsCurrentDSGmChangeCount,  
        ieee8021AsCurrentDSTimeOfLastGmChangeEvent,  
        ieee8021AsCurrentDSTimeOfLastGmPhaseChangeEvent,  
        ieee8021AsCurrentDSTimeOfLastGmFreqChangeEvent  
    }  
    STATUS          current  
    DESCRIPTION  
        "Objects in the System Current global group."  
    ::= { ieee8021AsGroups 2 }  
  
ieee8021AsSystemClockParentGroup OBJECT-GROUP  
    OBJECTS {  
        ieee8021AsParentDSParentClockIdentity,  
        ieee8021AsParentDSParentPortNumber,  
        ieee8021AsParentDSCumulativeRateRatio,  
        ieee8021AsParentDSGrandmasterIdentity,  
        ieee8021AsParentDSGrandmasterClockClass,  
        ieee8021AsParentDSGrandmasterClockAccuracy,  
        ieee8021AsParentDSGrandmasterOffsetScaledLogVariance,  
        ieee8021AsParentDSGrandmasterPriority1,  
        ieee8021AsParentDSGrandmasterPriority2  
    }  
    STATUS          current  
    DESCRIPTION  
        "Objects in the Clock Parent global group."  
    ::= { ieee8021AsGroups 3 }  
  
ieee8021AsSystemTimePropertiesGroup OBJECT-GROUP  
    OBJECTS {  
        ieee8021AsTimePropertiesDSCurrentUtcOffset,  
        ieee8021AsTimePropertiesDSCurrentUtcOffsetValid,  
        ieee8021AsTimePropertiesDSLeap59,  
        ieee8021AsTimePropertiesDSLeap61,  
        ieee8021AsTimePropertiesDSTimeTraceable,
```

```

        ieee8021AsTimePropertiesDSFrequencyTraceable,
        ieee8021AsTimePropertiesDSTimeSource
    }
    STATUS          current
    DESCRIPTION
        "Objects for the Time Properties Global group."
    ::= { ieee8021AsGroups 4 }

ieee8021AsPortDataSetGlobalGroup OBJECT-GROUP
    OBJECTS {
        ieee8021AsPortDSClockIdentity,
        ieee8021AsPortDSPortNumber,
        ieee8021AsPortDSPortRole,
        ieee8021AsPortDSPttPortEnabled,
        ieee8021AsPortDSIsMeasuringDelay,
        ieee8021AsPortDSAsCapable,
        ieee8021AsPortDSNeighborPropDelayHs,
        ieee8021AsPortDSNeighborPropDelayMs,
        ieee8021AsPortDSNeighborPropDelayLs,
        ieee8021AsPortDSNeighborPropDelayThreshHs,
        ieee8021AsPortDSNeighborPropDelayThreshMs,
        ieee8021AsPortDSNeighborPropDelayThreshLs,
        ieee8021AsPortDSDelayAsymmetryHs,
        ieee8021AsPortDSDelayAsymmetryMs,
        ieee8021AsPortDSDelayAsymmetryLs,
        ieee8021AsPortDSNeighborRateRatio,
        ieee8021AsPortDSInitialLogAnnounceInterval,
        ieee8021AsPortDSCurrentLogAnnounceInterval,
        ieee8021AsPortDSAnnounceReceiptTimeout,
        ieee8021AsPortDSInitialLogSyncInterval,
        ieee8021AsPortDSCurrentLogSyncInterval,
        ieee8021AsPortDSSyncReceiptTimeout,
        ieee8021AsPortDSSyncReceiptTimeoutTimeIntervalHs,
        ieee8021AsPortDSSyncReceiptTimeoutTimeIntervalMs,
        ieee8021AsPortDSSyncReceiptTimeoutTimeIntervalLs,
        ieee8021AsPortDSInitialLogPdelayReqInterval,
        ieee8021AsPortDSCurrentLogPdelayReqInterval,
        ieee8021AsPortDSAllowedLostResponses,
        ieee8021AsPortDSVersionNumber,
        ieee8021AsPortDSNupMs,
        ieee8021AsPortDSNupLs,
        ieee8021AsPortDSNdownMs,
        ieee8021AsPortDSNdownLs,
        ieee8021AsPortDSAcceptableMasterTableEnabled
    }
    STATUS          current
    DESCRIPTION
        "Objects for the port dataset global group."
    ::= { ieee8021AsGroups 5 }

ieee8021ASPortStatisticsGlobalGroup OBJECT-GROUP
    OBJECTS {
        ieee8021AsPortStatRxSyncCount,
        ieee8021AsPortStatRxFollowUpCount,
        ieee8021AsPortStatRxPdelayRequest,

```

```
        ieee8021AsPortStatRxPdelayResponse,
        ieee8021AsPortStatRxPdelayResponseFollowUp,
        ieee8021AsPortStatRxAnnounce,
        ieee8021AsPortStatRxPTPPacketDiscard,
        ieee8021AsPortStatRxSyncReceiptTimeouts,
        ieee8021AsPortStatAnnounceReceiptTimeouts,
        ieee8021AsPortStatPdelayAllowedLostResponsesExceeded,
        ieee8021AsPortStatTxSyncCount,
        ieee8021AsPortStatTxFollowUpCount,
        ieee8021AsPortStatTxPdelayRequest,
        ieee8021AsPortStatTxPdelayResponse,
        ieee8021AsPortStatTxPdelayResponseFollowUp,
        ieee8021AsPortStatTxAnnounce
    }
    STATUS          current
    DESCRIPTION
        "Objects in the Port statistics global group."
    ::= { ieee8021AsGroups 6 }

ieee8021AsAcceptableMasterBaseGroup OBJECT-GROUP
    OBJECTS {
        ieee8021AsAcceptableMasterTableDSMaxTableSize,
        ieee8021AsAcceptableMasterTableDSActualTableSize
    }
    STATUS          current
    DESCRIPTION
        "Objects for the Acceptable Master group."
    ::= { ieee8021AsGroups 7 }

ieee8021AsAcceptableMasterTableGroup OBJECT-GROUP
    OBJECTS {
        ieee8021AsAcceptableMasterClockIdentity,
        ieee8021AsAcceptableMasterPortNumber,
        ieee8021AsAcceptableMasterAlternatePriority1,
        ieee8021AsAcceptableMasterRowStatus
    }
    STATUS          current
    DESCRIPTION
        "Objects for the Acceptable Master group."
    ::= { ieee8021AsGroups 8 }

-- *****
-- MIB Module Compliance statements
-- *****

ieee8021AsCompliance MODULE-COMPLIANCE
    STATUS          current
    DESCRIPTION
        "The compliance statement for support of
         the IEEE8021-AS-MIB module."

    MODULE SNMPv2-MIB -- The SNMPv2-MIB, RFC 3418
```

```
MANDATORY-GROUPS {
    systemGroup
}

MODULE IF-MIB -- The interfaces MIB, RFC 2863
MANDATORY-GROUPS {
    ifGeneralInformationGroup
}

MODULE
MANDATORY-GROUPS {
    ieee8021ASSystemDefaultReqdGroup,
    ieee8021ASSystemCurrentGroup,
    ieee8021AsSystemClockParentGroup,
    ieee8021AsSystemTimePropertiesGroup,
    ieee8021AsPortDataSetGlobalGroup,
    ieee8021AsAcceptableMasterBaseGroup,
    ieee8021AsAcceptableMasterTableGroup
}

OBJECT ieee8021AsAcceptableMasterRowStatus
SYNTAX      RowStatus { active(1), notInService(2) }
WRITE-SYNTAX RowStatus { notInService(2), createAndGo(4),
                        destroy(6) }
DESCRIPTION "Support for createAndWait is not required."

GROUP ieee8021ASPortStatisticsGlobalGroup
DESCRIPTION
    "This group is optional and provides time-aware Bridges and
    end stations that choose to implement gPTP port statistics."

 ::= { ieee8021AsCompliances 1 }

END
```

Annex A

(normative)

Protocol Implementation Conformance Statement (PICS) proforma¹⁷

A.1 Introduction

The supplier of a protocol implementation that is claimed to conform to this standard shall complete the following PICS proforma.

A completed PICS proforma is the PICS for the implementation in question. The PICS is a statement of which capabilities and options of the protocol have been implemented. The PICS can have a number of uses, including the following:

- a) By the protocol implementer, as a checklist to reduce the risk of failure to conform to the standard through oversight;
- b) By the supplier and acquirer—or potential acquirer—of the implementation, as a detailed indication of the capabilities of the implementation, stated relative to the common basis for understanding provided by the standard PICS proforma;
- c) By the user—or potential user—of the implementation, as a basis for initially checking the possibility of interworking with another implementation (note that, while interworking can never be guaranteed, failure to interwork can often be predicted from incompatible PICS);
- d) By a protocol tester, as the basis for selecting appropriate tests against which to assess the claim for conformance of the implementation.

A.2 Abbreviations and special symbols

A.2.1 Status symbols

M	mandatory
O	optional
<i>O.n</i>	optional, but support of at least one of the group of options labeled by the same numeral n is required
X	prohibited
pred:	conditional-item symbol, including predicate identification (see A.3.4)
¬	logical negation, applied to a conditional item's predicate

A.2.2 General abbreviations

N/A	not applicable
PICS	Protocol Implementation Conformance Statement

¹⁷*Copyright release for PICS proformas:* Users of this standard may freely reproduce the PICS proforma in this annex so that it can be used for its intended purpose and may further publish the completed PICS.

A.3 Instructions for completing the PICS proforma

A.3.1 General structure of the PICS proforma

The first part of the PICS proforma, implementation identification and protocol summary, is to be completed as indicated with the information necessary to identify fully both the supplier and the implementation.

The main part of the PICS proforma is a fixed-format questionnaire, divided into several subclauses, each containing a number of individual items. Answers to the questionnaire items are to be provided in the rightmost column, either by simply marking an answer to indicate a restricted choice (usually Yes or No), or by entering a value or a set or range of values. (Note that there are some items where two or more choices from a set of possible answers can apply; all relevant choices are to be marked.)

Each item is identified by an item reference in the first column. The second column contains the question to be answered; the third column records the status of the item—whether support is mandatory, optional, or conditional: see also A.3.4. The fourth column contains the reference or references to the material that specifies the item in the main body of this standard, and the fifth column provides the space for the answers.

A supplier may also provide (or be required to provide) further information, categorized as either Additional Information or Exception Information. When present, each kind of further information is to be provided in a further subclause of items labeled A_i or X_i , respectively, for cross-referencing purposes, where i is any unambiguous identification for the item (e.g., simply a numeral). There are no other restrictions on its format and presentation.

A completed PICS proforma, including any Additional Information and Exception Information, is the Protocol Implementation Conformation Statement for the implementation in question.

NOTE—Where an implementation is capable of being configured in more than one way, a single PICS may be able to describe all such configurations. However, the supplier has the choice of providing more than one PICS, each covering some subset of the implementation's configuration capabilities, in case that makes for easier and clearer presentation of the information.

A.3.2 Additional Information

Items of Additional Information allow a supplier to provide further information intended to assist the interpretation of the PICS. It is not intended or expected that a large quantity will be supplied, and a PICS can be considered complete without any such information. Examples might be an outline of the ways in which a (single) implementation can be set up to operate in a variety of environments and configurations, or information about aspects of the implementation that are outside the scope of this standard but that have a bearing upon the answers to some items.

References to items of Additional Information may be entered next to any answer in the questionnaire and may be included in items of Exception Information.

A.3.3 Exception Information

It may occasionally happen that a supplier will wish to answer an item with mandatory status (after any conditions have been applied) in a way that conflicts with the indicated requirement. No preprinted answer will be found in the Support column for this; instead, the supplier shall write the missing answer into the Support column, together with an X_i reference to an item of Exception Information, and shall provide the appropriate rationale in the Exception item itself.

An implementation for which an Exception item is required in this way does not conform to this standard.

NOTE—A possible reason for the situation described above is that a defect in this standard has been reported, a correction for which is expected to change the requirement not met by the implementation.

A.3.4 Conditional status

A.3.4.1 Conditional items

The PICS proforma contains a number of conditional items. These are items for which both the applicability of the item itself, and its status if it does apply—mandatory or optional—are dependent upon whether or not certain other items are supported.

Where a group of items is subject to the same condition for applicability, a separate preliminary question about the condition appears at the head of the group, with an instruction to skip to a later point in the questionnaire if the Not Applicable (N/A) answer is selected. Otherwise, individual conditional items are indicated by a conditional symbol in the Status column.

A conditional symbol is of the form “**pred:** S” where **pred** is a predicate as described in A.3.4.2, and S is a status symbol, M or 0.

If the value of the predicate is true (see A.3.4.2), the conditional item is applicable, and its status is indicated by the status symbol following the predicate; the answer column is to be marked in the usual way. If the value of the predicate is false, the N/A answer is to be marked.

A.3.4.2 Predicates

A predicate is one of the following:

- a) An item-reference for an item in the PICS proforma; the value of the predicate is true if the item is marked as supported, and is false otherwise;
- b) A predicate-name, for a predicate defined as a Boolean expression constructed by combining item-references using the Boolean operator OR; the value of the predicate is true if one or more of the items is marked as supported;
- c) The logical negation symbol “¬” prefixed to an item-reference or predicate-name; the value of the predicate is true if the value of the predicate formed by omitting the “¬” symbol is false, and vice versa.

Each item whose reference is used in a predicate or predicate definition, or in a preliminary question for grouped conditional items, is indicated by an asterisk in the Item column.

A.4 PICS proforma for IEEE Std 802.1AS-2011

NOTE 1—Only the first three items are required for all implementations; other information may be completed as appropriate in meeting the requirement for full identification.

NOTE 2—The terms Name and Version should be interpreted appropriately to correspond with a supplier’s terminology (e.g., Type, Series, Model).

A.5 Major capabilities

Item	Feature	Status	References	Support
MIB	Is the IEEE 8021-AS-MIB module fully supported (per its MODULE-COMPLIANCE)?	O	Clause 15	Yes [] N/A []
MINTA	Does the device support media-independent slave functionality on at least one port?	M	10.2.12	Yes []
BMC	Does the device implement the best master clock algorithm?	M	10.3	Yes []
SIG	Does the device transmit signaling messages?	O	10.5.4	Yes [] No []
GMCAP	Is the device capable of acting as a grandmaster?	O	8.6.2.1, 10.1.2	Yes [] No []
BRDG	Does the device act as a time-aware Bridge on two or more ports?	O	10.2.6	Yes [] No []
MIMSTR	Does the device support media-independent master functionality on at least one port?	GMCAP or BRDG:M	10.2.11	Yes [] N/A []
MDFDPP	Does the device support media-dependent full-duplex, point-to-point functionality on one or more ports?	O.1	11.1	Yes [] No []
MDDOT11	Does the device support media-dependent IEEE 802.11 link functionality on one or more ports?	O.1	12.1	Yes [] No []
MDEPON	Does the device support IEEE 802.3 Passive Optical Networking (EPON)?	O.1	13.1	Yes [] No []
MDGHN	Does the device support media-dependent G.hn functionality on one or more ports?	O.1	Annex E	Yes [] No []
MDMOCA	Does the device support media-dependent MoCA functionality on one or more ports?	O.1	Annex E	Yes [] No []
MDCSN	Does the device support media-dependent CSN functionality on one or more ports?	MDGHN or MDMOCA:M	Annex E	Yes [] No []
MGT	Is management of the timing synchronization in Bridges supported?	O	Clause 15	Yes [] No []

A.6 Media access control methods

Item	Feature	Status	References	Support
MAC-IEEE-802.3 MAC-IEEE-802.11	Which MAC methods are implemented in conformance with the relevant MAC standards	O:2 O:2	11.1 12.1	Yes [] No [] Yes [] No []
MAC-1	Has a PICS been completed for each of the MAC methods implemented as required by the relevant MAC Standards?	M		Yes []
MAC-2	Do all the MAC methods implemented support the MAC Timing aware Service as specified?	M	Clause 11 Clause 12 Clause 13	Yes []

A.7 Minimal time-aware system

Item	Feature	Status	References	Support
MINTA-1	Does the device implement the functionality specified by the SiteSyncSync state machine in Figure 10-3 in compliance with the requirements of 10.2.6?	M	10.2.6	Yes []
MINTA-2	Does the device implement the functionality specified by the PortSyncSyncReceive state machine in Figure 10-4 on each port in compliance with the requirements of 10.2.7?	M	10.2.7	Yes []
MINTA-3	Does the device implement the functionality specified by the ClockSlaveSync state machine in Figure 10-9 in compliance with the requirements of 10.2.12?	M	10.2.12	Yes []
MINTA-4	Does the device port sending a Signaling message that contains a message interval request TLV adjust its syncReceiptTimeoutTimeInterval in compliance with the requirements of 10.5.4.3.7 and Table 10-12?	SIG:M	10.5.4.3.7	Yes [] N/A []
MINTA-5	Is the clockIdentity constructed in compliance with the requirements of 8.5.2.2, its subclauses, and Table 8-1?	M	8.5.2.2	Yes []
MINTA-6	Is the domain number for all transmitted messages set to 0 in compliance with the requirements of 8.1?	M	8.1	Yes []
MINTA-7	Is the IEEE 802.1AS time measured relative to the PTP epoch in compliance with the requirements of 8.2.2?	M	8.2.2	Yes []
MINTA-8	If path delay asymmetry is modeled by this device does it comply with the requirements of 8.3?	O	8.3	Yes [] No []
MINTA-9	Do all derived data types that are transmitted in IEEE 802.1AS messages and headers comply with 6.3.4?	M	6.3.4	Yes []

Item	Feature	Status	References	Support
MINTA-10	Is the granularity of the local clock 40 ns or better in compliance with the requirements of B.1.2?	M	B.1.2	Yes []
MINTA-11	Is the frequency of the local clock relative to TAI ± 100 ppm in compliance with the requirements of B.1.1?	M	B.1.1	Yes []
MINTA-12	Does the time-aware system ignore TLVs, of Announce and Signaling messages, that it cannot parse and attempt to parse the next TLV, in compliance with the requirements of 10.5.1?	M	10.5.1	Yes []

A.8 Signalling

Item	Feature	Status	References	Support
SIG-1	Do the sequence numbers of Signaling messages comply with the requirements of 10.4.7?	SIG:M	10.4.7	Yes []
SIG-2	Does the Signaling message body comply with the requirements of 10.5.4.1 and Table 10-9?	SIG:M	10.5.4.1	Yes []
SIG-3	Does the Signaling message header comply with the requirements of Table 10-4 and 10.5.2.1, including all of its subclauses (10.5.2.2.1–10.5.2.2.11)?	SIG:M	10.5.2.1	Yes []
SIG-4	Are all Signaling message reserved fields equal to 0 in compliance with the requirements of 10.5.1?	SIG:M	10.5.1	Yes []
SIG-5	Is the destination MAC address for all Signaling messages equal to 01:80:C2:00:00:0E in compliance with the requirements of 10.4.3?	SIG:M	10.4.3	Yes []
SIG-6	Is the ethertype for all Signaling messages equal to 0x88F7 in compliance with the requirements of 10.4.4?	SIG:M	10.4.4	Yes []
SIG-7	Does the message interval request TLV for signaling messages comply with the requirements in 10.5.4.3.2 through 10.5.4.3.9 and Table 10-10?	SIG:M	10.5.4.3.2	Yes []

A.9 Best master clock

Item	Feature	Status	References	Support
BMC-1	Does the device implement the functionality specified by the PortAnnounceReceive state machine in Figure 10-12 on each port in compliance with the requirements of 10.3.10?	M	10.3.10	Yes []
BMC-2	Does the device implement the functionality specified by the PortAnnounceInformation state machine in Figure 10-13 on each port in compliance with the requirements of 10.3.11?	M	10.3.11	Yes []
BMC-3	Does the device implement the functionality specified by the PortRoleSelection state machine in Figure 10-14 on each port in compliance with the requirements of 10.3.12?	M	10.3.12	Yes []
BMC-4	If the value of clockA's SystemIdentity is less than that of clockB, is clockA selected as Grandmaster in compliance with the requirements of 10.3.2?	M	10.3.2	Yes []
BMC-5	Does the value of priority1 comply with the requirements of 8.6.2.1?	M	8.6.2.1	Yes []
BMC-6	Does the value of clockClass comply with the requirements of 8.6.2.2?	M	8.6.2.2	Yes []
BMC-7	Does the value of priority2 comply with the requirements of 8.6.2.5?	M	8.6.2.5	Yes []
BMC-8	Does the value of clockAccuracy comply with requirements of 8.6.2.3?	M	8.6.2.3	Yes []
BMC-9	Does the value of offsetScaledVariance comply with the requirements of 8.6.2.4?	M	8.6.2.4	Yes []
BMC-10	Does the value of timeSource comply with requirements of 8.6.2.7 and Table 8-3?	M	8.6.2.7	Yes []
BMC-11	Is the port number equal to 1 in compliance with the requirements of 8.5.2.3?	~BRDG:M	8.5.2.3	Yes [] N/A []
BMC-12	Are the ports numbered 1 through N for each of N ports in compliance with the requirements of 8.5.2.3?	M	8.5.2.3	Yes []
BMC-13	Does the clockIdentity field comply with the requirements of 8.5.2.2?	M	8.5.2.2	Yes []
BMC-14	When no grandmaster capable device is available does the behavior of the device comply with the requirements of 10.2.12.2, i.e., the clockSlaveTime should be provided by the local clock?	M	10.2.12.2	Yes []
BMC-15	Does the value of announceReceiptTimeout comply with the requirements of 10.6.3.2?	M	10.6.3.2	Yes []
BMC-16	Does the SlavePort remove the port from the BMC selection after announceReceiptTimeout expires in compliance with the requirements of 10.6.3.2?	M	10.6.3.2	Yes []
BMC-17	Does the value of syncReceiptTimeout comply with the requirements of 10.6.3.1?	M	10.6.3.1	Yes []

Item	Feature	Status	References	Support
BMC-18	Does the SlavePort remove the port from the BMC selection after syncReceiptTimeout expires in compliance with 10.6.3.1?	M	10.6.3.1	Yes []
BMC-19	Does the device port sending a message interval request signaling message adjust its announceReceiptTimeoutTimeInterval in compliance with the requirements of 10.5.4.3.8 and Table 10-13?	SIG:M	10.5.4.3.8	Yes []
BMC-20	If the device implements the ClockSourceTime interface, does the value of lastGmPhaseChange comply with the requirements of 9.2.2 and 6.3.3.3?	O	9.2.2	Yes []
BMC-21	Does the transmitted timing information comply with the requirements of 10.3.1?	GMCAP:M	10.3.1	Yes []

A.10 Grandmaster-capable system

Item	Feature	Status	References	Support
GMCAP-1	Does the device implement the the functionality specified by the ClockMasterSyncSend state machine in compliance with the requirements of 10.2.8 and Figure 10-5?	GMCAP:M	10.2.8	Yes []
GMCAP-2	Does the device implement the the functionality specified by the ClockMasterSyncOffset state machine in compliance with the requirements of 10.2.9 and Figure 10-6?	GMCAP:M	10.2.9	Yes []
GMCAP-3	Does the device implement the the functionality specified by the ClockMasterSyncReceive state machine in compliance with the requirements of 10.2.10 and Figure 10-7?	GMCAP:M	10.2.10	Yes []

A.11 Media-independent master

Item	Feature	Status	References	Support
MIMSTR-1	Does the device implement the functionality of the AnnounceIntervalSetting state machine in compliance with the requirements of 10.3.14 and Figure 10-16 on each port?	MIMSTR:M	10.3.14	Yes []
MIMSTR-2	Does the device implement the functionality of the PortSyncSyncSend state machine in compliance with the requirements of 10.2.11 and Figure 10-8 on each port?	MIMSTR:M	10.2.11	Yes []
MIMSTR-3	Does the device implement the functionality of the PortAnnounceTransmit state machine in compliance with the requirements of 10.3.13 and Figure 10-15 on each port?	MIMSTR:M	10.3.13	Yes []
MIMSTR-4	Does the destination MAC address of all Announce messages equal 01:80:C2:00:00:0E?	MIMSTR:M	10.4.3	Yes []
MIMSTR-5	Does the ethertype of all Announce messages equal 0x88F7?	MIMSTR:M	10.4.4	Yes []
MIMSTR-6	Do the sequence numbers of Announce messages comply with the requirements of 10.4.7?	MIMSTR:M	10.4.7	Yes []
MIMSTR-7	Does the Announce message header comply with Table 10-4 and 10.5.2.2, including all of its subclauses (10.5.2.2.1–10.5.2.2.11)?	MIMSTR:M	10.5.2.1	Yes []
MIMSTR-8	Does the Announce message body comply with the requirements in 10.5.3.1 and Table 10-7?	MIMSTR:M	10.5.3.1	Yes []
MIMSTR-9	Are all Announce message reserved fields equal to 0?	MIMSTR:M	10.5.1	Yes []
MIMSTR-10	If it is not otherwise specified is the logAnnounceInterval equal to zero or within the allowed range?	MIMSTR:M	10.6.2.1	Yes []
MIMSTR-11	Does the value of currentUtcOffset comply with the requirements of 8.2.3?	MIMSTR:M	8.2.3	Yes []
MIMSTR-12	Do the values of the leap59, leap61, and currentUtcOffsetValid flags comply with the requirements of 10.3.8?	MIMSTR:M	10.3.8	Yes []
MIMSTR-13	Does this device ensure that messages that traverse it or originate from it are not transmitted with VLAN tags in compliance with the requirements of 11.3.3?	MIMSTR:M	11.3.3	Yes []
MIMSTR-14	Is the computation of cumulative rateRatio in accordance with 10.2.7.3?	MIMSTR:M	10.2.7.3	Yes [] N/A []

A.12 Media-dependent, full-duplex, point-to-point link

Item	Feature	Status	References	Support	
MDFDPP-1	Does this port implement the functionality of the MDSyncReceiveSM state machine in compliance with the requirements of 11.2.13 and Figure 11-6?	MDFDPP:M	11.2.13	Yes []	
MDFDPP-2	Does this port implement the functionality of the MDSyncSendSM state machine in compliance with the requirements of 11.2.14 and Figure 11-7?	MIMSTR and MDFDPP:M	11.2.14	Yes []	
MDFDPP-3	Does this port implement the functionality of the MDPdelayRequest state machine in compliance with the requirements of 11.2.15 and Figure 11-8?	MDFDPP:M	11.2.15	Yes []	
MDFDPP-4	Does this port implement the functionality of the MDPdelayResponse state machine in compliance with the requirements of 11.2.16.2 and Figure 11-9?	MDFDPP:M	11.2.16.2	Yes []	
MDFDPP-5	Does this port implement the functionality of the LinkDelaySyncIntervalSetting state machine in compliance with the requirements of 11.2.17 and Figure 11-10?	MDFDPP:M	11.2.17	Yes []	
MDFDPP-6	Does this port timestamp Sync messages on ingress with respect to the LocalClock in compliance with 11.3.2.1 and 11.3.9?	MDFDPP:M	11.3.2.1	Yes []	
MDFDPP-7	Does this port timestamp Sync messages on egress with respect to the LocalClock in compliance with the requirements of 11.3.2.1 and 11.3.9?	MIMSTR and MDFDPP:M	11.3.2.1	Yes []	
MDFDPP-8	Does this port timestamp Pdelay_Req messages on ingress and egress with respect to the LocalClock in compliance with the requirements of 11.3.2.1 and 11.3.9?	MDFDPP:M	11.3.2.1	Yes []	
MDFDPP-9	Does this port timestamp Pdelay_Resp messages on ingress and egress with respect to the LocalClock in compliance with the requirements of 11.3.2.1 and 11.3.9?	MDFDPP:M	11.3.2.1	Yes []	
MDFDPP-10	Are all IEEE 802.1AS messages on this port sent without a Q-tag in compliance with the requirements of 11.3.3?	MDFDPP:M	11.3.3	Yes []	
MDFDPP-11	Do all media-dependent messages transmitted on this port use a destination MAC address taken from Table 11-1 in compliance with the requirements of 11.3.4 [01-80-C2-00-00-0E]?	MDFDPP:M	11.3.4	Yes []	
MDFDPP-12	Do all media-dependent messages transmitted on this port use a source MAC address that is assigned to that port in compliance with the requirements of 11.3.4?	MDFDPP:M	11.3.4	Yes []	
MDFDPP-13	Do all media-dependent message transmitted on this port us an ethertype specified in Table 11-2 [0x88F7]?	MDFDPP:M	11.3.5	Yes []	

Item	Feature	Status	References	Support
MDFDPP-14	Does the header of all the media-dependent messages on this port comply with the requirements of the subclauses of 11.4.2 and Table 10-4?	MDFDPP:M	11.4.2	Yes [] N/A []
MDFDPP-15	Does the body of Sync messages sent on this port comply with the requirements of 11.4.3 and Table 11-8?	MDFDPP:M	11.4.3	Yes []
MDFDPP-16	Does the body of Follow_Up messages sent on this port comply with the requirements of 11.4.4 and 6.3.3.3 (lastGmPhaseChange) and Table 11-9?	MDFDPP:M	11.4.4	Yes []
MDFDPP-17	Does the body of Pdelay_Req messages sent on this port comply with the requirements of 11.4.5 and Table 11-11?	MDFDPP:M	11.4.5	Yes []
MDFDPP-18	Does the body of Pdelay_Resp messages sent on this port comply with the requirements of 11.4.6 and Table 11-12?	MDFDPP:M	11.4.6	Yes []
MDFDPP-19	Does the body of Pdelay_Resp_Follow_Up messages sent on this port comply with the requirements of 11.4.7 and Table 11-13?	MDFDPP:M	11.4.7	Yes []
MDFDPP-20	Are all reserved fields in media-dependent messages sent on this port set to 0 in compliance with the requirements of 11.4.1?	MDFDPP:M	11.4.1	Yes []
MDFDPP-21	Do the Sync message sequence numbers comply with the requirements of 11.3.8?	MIMSTR and MDFDPP:M	11.3.8	Yes [] N/A []
MDFDPP-22	Do the Pdelay_Req message sequence numbers comply with the requirements of 11.3.8?	MDFDPP:M	11.3.8	Yes []
MDFDPP-23	Does the Pdelay mean request transmission interval comply with the requirements of 11.5.2.2?	MDFDPP:M	11.5.2.2	Yes []
MDFDPP-24	Does the Sync mean transmission interval comply with the requirements of 11.5.2.3?	MDFDPP:M	11.5.2.3	Yes []
MDFDPP-25	Does the full-duplex, point-to-point media-dependent layer set the asCapable global variable in the media-independent PortSync entity in compliance with the requirements of 11.2.2?	MDFDPP:M	11.2.2	Yes []
MDFDPP-26	Does the device's use of flow control comply with the requirements of 11.2.3 and 11.2.4?	MDFDPP:M	11.2.3, 11.2.4	Yes []
MDFDPP-27	Does the device consider the port to not be exchanging Pdelay messages when a valid response is not received in compliance with the requirements of 11.5.3?	MDFDPP:M	11.5.3	Yes []
MDFDPP-28	Does the time-aware system ignore TLVs, of PTP messages, that it cannot parse and attempt to parse the next TLV, in compliance with the requirements of 11.4.1?	MDFDPP:M	11.4.1	Yes []

A.13 Media-dependent IEEE 802.11 link

Item	Feature	Status	References	Support
MDDOT11-1	Does the IEEE 802.11 MAC implement the master port functionality in compliance with the requirements of 12.4.1?	MDDOT11 and MIMSTR:M	12.4.1	Yes []
MDDOT11-2	Does the IEEE 802.11 MAC implement the master port functionality in compliance with the requirements of 12.4.2?	MDDOT11:M	12.4.2	Yes []
MDDOT11-3	Does the IEEE 802.11 MAC determine the value of asCapable in compliance with the requirements of 12.3?	MDDOT11:M	12.3	Yes []
MDDOT11-4	Does the IEEE 802.11 MAC determine the value of mean time interval between synchronization messages in compliance with the requirements of 12.6?	MDDOT11 and MIMSTR:M	12.6	Yes []

A.14 Media-dependent IEEE 802.3 EPON link

Item	Feature	Status	References	Support
MDEPON-1	Does the TIMESYNC message format comply with the requirements of 13.3 and Table 13-1?	MDEPON:M	13.3	Yes []
MDEPON-2	Does the device implement the functionality specified by the requester state machine in compliance with the requirements of 13.8.1 and Figure 13-3?	MDEPON and MIMSTR:M	13.8.1.4	Yes []
MDEPON-3	Does the device implement the functionality specified by the responder state machine in compliance with the requirements of 13.8.2 and Figure 13-4?	MDEPON:M	13.8.2.4	Yes []
MDEPON-4	Does the TIMESYNC message transmission interval comply with the requirements of 13.9.1 and 13.9.2?	MDEPON:M	13.9.1, 13.9.2	Yes []
MDEPON-5	Does the implementation of best master selection comply with the requirements of 13.1.3?	MDEPON:M	13.1.3	Yes []
MDEPON-6	Does the determination of the value of asCapable comply with the requirements of 13.4?	MDEPON:M	13.4	Yes []

A.15 Media-dependent CSN link

Item	Feature	Status	References	Support
MDCSN-1	Does the device implement the functionality of the MDSyncSendSM state machine in compliance with 11.2.14?	MDCSN and MIMSTR:M	11.2.14	Yes []
MDCSN-2	Does the device implement the functionality of the MDSyncReceiveSM state machine in compliance with 11.2.13?	MDCSN:M	11.2.13	Yes []
MDCSN-3	Does the device calculate path delay in compliance with the requirement of E.4 and its subclauses?	MDCSN:M	E.4.1, E.4.2, E.4.3	Yes []
MDCSN-4	Does the device propagate synchronized time in compliance with the requirements of E.5 and its subclauses?	MDCSN:M	E.5.1, E.5.2	Yes []
MDCSN-5	Does the device act as grandmaster in compliance with the requirements of E.7 and its subclauses?	GMCAP and MDCSN:M	E.7	Yes []
MDCSN-6	Does the device comply with the performance requirements of E.8?	GMCAP and MDCSN:M	E.8	Yes []

A.16 Media-dependent MoCA link

Item	Feature	Status	References	Support
MDMOCA-1	Does the MoCA MD entity propagate Sync messages in compliance with the requirements of E.6.1?	MDMOCA:M	E.6.1	Yes []

A.17 Media-dependent ITU-T G.hn link

Item	Feature	Status	References	Support
MDGHN-1	Does the GHN MD entity propagate Sync messages in compliance with the requirements of E.6.2?	MDGHN:M	E.6.2	Yes []

Annex B

(normative)

Performance requirements

B.1 LocalClock requirements

B.1.1 Frequency accuracy

The fractional frequency offset of the LocalClock relative to the TAI frequency (see Annex C) shall be within ± 100 ppm.

B.1.2 Time measurement granularity

The granularity with which the LocalClock measures time shall be less than or equal to 40 ns.

B.1.3 Noise generation

B.1.3.1 Jitter generation

The jitter generation of the free-running LocalClock shall not exceed 2 ns peak-to-peak, when measured over a 60 s measurement interval using a band-pass filter that consists of the following low-pass and high-pass filters:

- a) High-pass filter: first-order characteristic (i.e., 0 dB gain peaking), 20 dB/decade roll-off, and 3 dB bandwidth (i.e., corner frequency) of 10 Hz
- b) Low-pass filter: maximally-flat (i.e., Butterworth) characteristic, 60 dB/decade roll-off, and 3 dB bandwidth equal to the Nyquist rate of the LocalClock entity (i.e., one-half the nominal frequency of the LocalClock entity)

B.1.3.2 Wander generation

Wander generation is specified using the Time Deviation (TDEV) parameter. The corresponding values of the Allan Deviation (ADEV) and PTP Deviation (PTPDEV) are given for information; the former is also useful in describing the wander generation of clocks and oscillators, and the latter is related to the `offsetScaledLogVariance` attribute (see 8.6.2.4). Information on ADEV and TDEV are contained in ITU-T G.810 [B13] and IEEE Std 1139™-1999 [B6]. Information on ADEV and PTPDEV are contained in 7.6.3 of IEEE Std 1588-2008.

TDEV, denoted $\sigma_x(\tau)$, is estimated from a set of measurements, as shown in Equation (B.1):

$$\sigma_x(\tau) = \sqrt{\frac{1}{6n^2(N-3n+1)} \sum_{j=1}^{N-3n+1} \left[\sum_{i=j}^{n+j-1} (x_{i+2n} - 2x_{i+n} + x_i) \right]^2}, n = 1, 2, \dots, \left\lfloor \frac{N}{3} \right\rfloor \quad (\text{B.1})$$

where

$\tau = n\tau_0$ = observation interval
 τ_0 = sampling interval
 N = total number of samples [$(N-1)\tau_0$ = measurement interval]
 $\lfloor y \rfloor$ denotes the floor function, i.e., the greatest integer less than or equal to y
 x_i = measured phase (time) error at the i^{th} sampling time [the units of x_i and $\sigma_x(\tau)$ are the same]

ADEV, denoted $\sigma_y(\tau)$, is estimated from a set of measurements, as shown in Equation (B.2):

$$\sigma_y(\tau) = \sqrt{\frac{1}{2n^2\tau_0^2(N-2n)} \sum_{i=1}^{N-2n} (x_{i+2n} - 2x_{i+n} + x_i)^2}, n = 1, 2, \dots, \left\lfloor \frac{N-1}{2} \right\rfloor \quad (\text{B.2})$$

where the notation is the same as defined above for TDEV.

PTPDEV, denoted $\sigma_{PTP}(\tau)$, is estimated from a set of measurements, as shown in Equation (B.3):

$$\sigma_{PTP}(\tau) = \sqrt{\frac{1}{6n^2(N-2n)} \sum_{i=1}^{N-2n} (x_{i+2n} - 2x_{i+n} + x_i)^2}, n = 1, 2, \dots, \left\lfloor \frac{N-1}{2} \right\rfloor \quad (\text{B.3})$$

where the notation is the same as defined above for TDEV.

TDEV, ADEV, and PTPDEV are second-order statistics on the phase error. All three statistics are functions of second differences of the phase error. This means that these statistics are not affected by a constant frequency offset. This behavior is desired, because these statistics are used here to constrain noise generation.

TDEV for the LocalClock entity shall not exceed the mask of Table B.1 and Figure B.1, when measured using

- a) A measurement interval that is at least 120 s (i.e., at least 12 times the longest observation interval),
- b) A low-pass filter with 3 dB bandwidth of 10 Hz, first-order characteristic, and 20 dB/decade roll-off, and
- c) A sampling interval τ_0 that does not exceed 1/30 s.

Table B.1—Wander generation TDEV requirement for LocalClock entity

TDEV limit	Observation interval τ
No requirement	$\tau < 0.05$ s
5.0τ ns	$0.05 \leq \tau \leq 10$ s
No requirement	$\tau > 10$ s

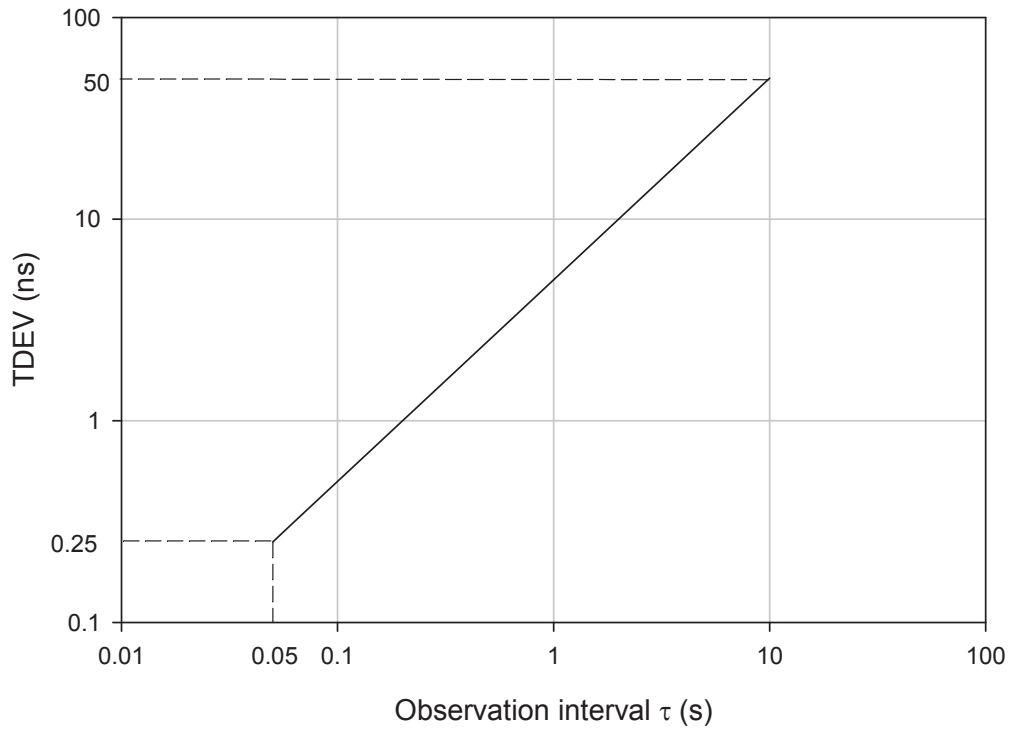

Figure B.1—Wander generation (TDEV) requirement for LocalClock entity

The ADEV limit that corresponds to the TDEV requirement of Table B.1 and Figure B.1 is shown in Table B.2 and Figure B.2, respectively.

Table B.2—ADEV limit corresponding to wander generation requirement of Table B.1

ADEV limit	Observation interval τ
No requirement	$\tau < 0.05$ s
1.054×10^{-8}	$0.05 \leq \tau \leq 10$ s
No requirement	$\tau > 10$ s

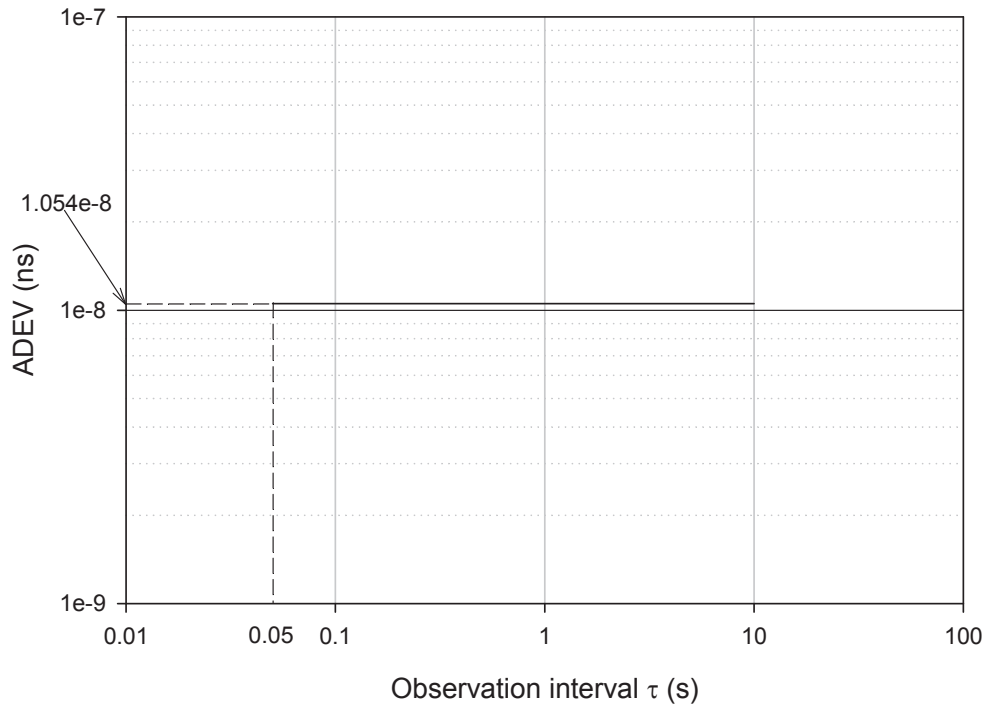

Figure B.2—ADEV limit corresponding to wander generation requirement of Figure B.1

The PTPDEV limit that corresponds to the TDEV requirement of Table B.1 and Figure B.1 is shown in Table B.3 and Figure B.3, respectively.

Table B.3—PTPDEV limit corresponding to wander generation requirement of Table B.1

PTPDEV limit	Observation interval τ
No requirement	$\tau < 0.05$ s
6.08τ ns	$0.05 \leq \tau \leq 10$ s
No requirement	$\tau > 10$ s

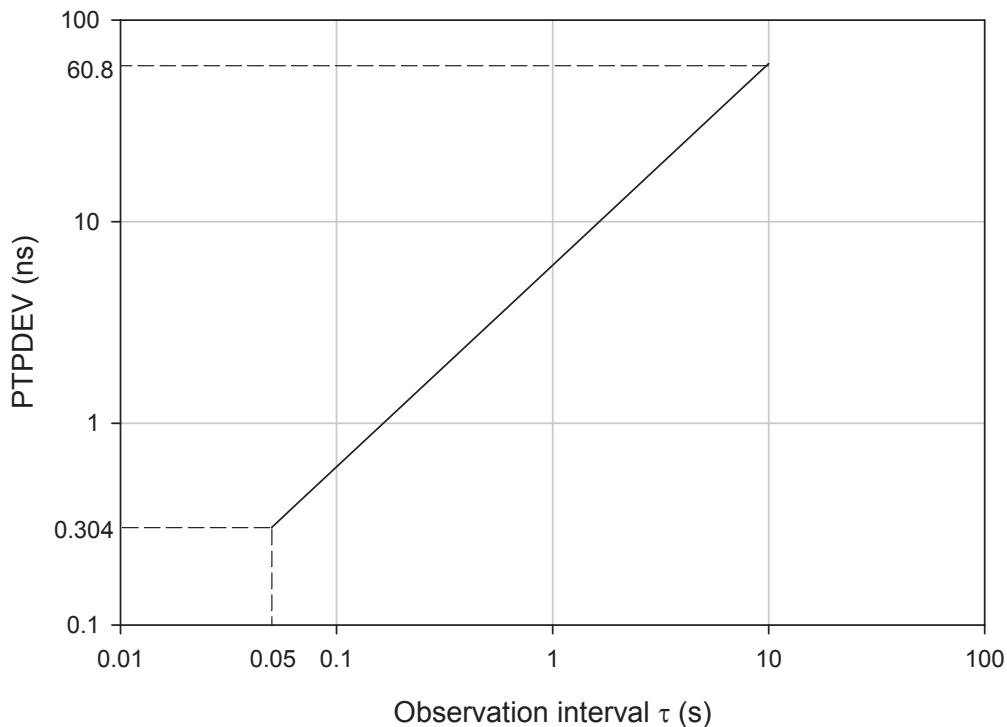

Figure B.3—PTPDEV limit corresponding to wander generation requirement of Figure B.1

B.2 Time-aware system requirements

B.2.1 General

In order to achieve the accuracy goals, certain constraints are placed on the responsiveness and accuracy of time-aware systems.

B.2.2 Residence time

The residence time (see 3.17) of a time-aware system, measured relative to the TAI frequency (see 8.2), shall be less than or equal to 10 ms.

B.2.3 Pdelay turnaround time

The pdelay turnaround time is the duration of the interval between the receipt of a Pdelay_Req message by a port of a time-aware system, and the sending of the corresponding Pdelay_Resp message.

The pdelay turnaround time of a time-aware system, measured relative to the TAI frequency (see 8.2), shall be less than or equal to 10 ms.

B.2.4 Measurement of rate ratio

This standard requires the measurement of rate ratio or, equivalently, frequency offset, in several subclauses (see 10.2.9, 10.2.10, 11.2.15, 12.4.2, E.4.2, and E.4.3.1). The error inherent in any scheme used to measure rate ratio shall not exceed ± 0.1 ppm.

NOTE—This requirement is consistent with a rate ratio measurement made by measuring the default Pdelay_Req message transmission interval (the nominal interval duration is 1 s, see 11.5.2.2) relative to the clocks whose rate ratio is desired, assuming the clocks meet the time measurement granularity requirement of B.1.2 (i.e., no worse than 40 ns).

B.3 End-to-end time-synchronization performance

The requirements of this standard and of standards referenced for each medium ensure that any two time-aware systems separated by six or fewer time-aware systems (i.e., seven or fewer hops) will be synchronized to within 1 μ s peak-to-peak of each other during steady-state operation (i.e., each time-aware system receives time-synchronization information every sync interval).

B.4 End-to-end jitter and wander performance

The requirements of this standard and standards referenced by this standard ensure that the synchronized time at a time-aware system that is separated from the grandmaster by six or fewer time-aware systems (i.e., seven or fewer hops) will, when filtered by a reference endpoint filters with rolloff of 20 dB/decade, gain peaking that does not exceed 0.1 dB, and bandwidth that does not exceed the value given in each entry of Table B.4, have maximum time interval error (MTIE) that does not exceed the maximum time interval error (MTIE) for that entry of Table B.4, and jitter that does not exceed the peak-to-peak jitter of Table B.4 when measured through the corresponding high-pass jitter measurement filter given in Table B.4.

NOTE—For example, the endpoint filter can be of the following form:

$$y_k = a_1 y_{k-1} + a_2 y_{k-2} + \dots + a_n y_{k-n} + b_0 x_k + b_1 x_{k-1} + \dots + b_n x_{k-n}$$

where the x_k are the unfiltered synchronized time values, the y_k are the filtered synchronized time values, and the a_k and b_k are filter coefficients. The a_k and b_k are chosen such that the filter has desired bandwidth and gain peaking that does not exceed 0.1 dB. The preceding equation is a general infinite impulse response (IIR) digital filter. Simplified forms, e.g., a second order IIR filter obtained by setting $n = 2$, or a finite impulse response (FIR) filter obtained by setting the a_k to zero are possible.

Table B.4—Maximum endpoint filter bandwidths needed to meet respective MTIE masks and peak-to-peak jitter limits

Endpoint filter maximum bandwidth (Hz)	Corresponding MTIE mask of Figure B.4 that is not exceeded	Corresponding jitter high-pass measurement filter (Hz)	Corresponding peak-to-peak jitter than is not exceeded (ns)
10	Mask 2 (Figure B.4, Table B.6)	8000	10.2
1	Mask 1 (Figure B.4, Table B.5)	200	11.1
0.01	Mask 3 (Figure B.4, Table B.7)	—	—

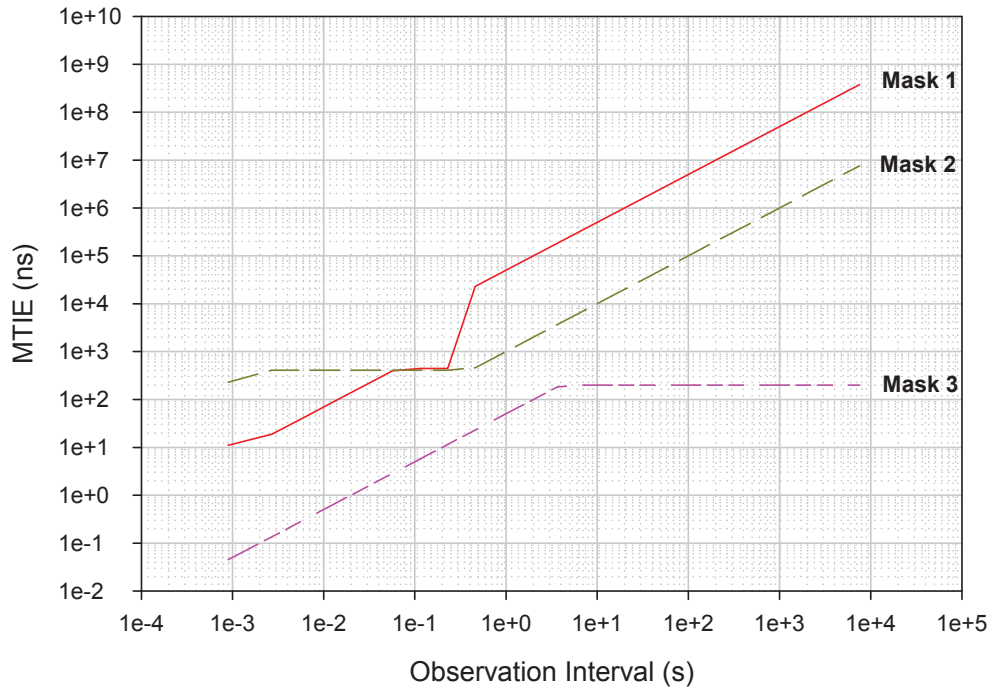

Figure B.4—MTIE masks met for maximum endpoint filter bandwidths of Table B.4

Table B.5—Breakpoints for Mask 1

Observation interval S (s)	MTIE (ns)
$0.05 \leq S < 0.0637$	$6954.8S$
$0.0637 \leq S < 0.3183$	443
$0.3183 \leq S \leq 10000$	$50000S$

Table B.6—Breakpoints for Mask 2

Observation interval S (s)	MTIE (ns)
$0.05 \leq S < 0.4069$	407
$0.4069 \leq S < 10000$	$1000S$

Table B.7—Breakpoints for Mask 3

Observation interval S (s)	MTIE (ns)
$6.67 \times 10^{-4} \leq S < 4.0$	$50S$
$4.0 \leq S < 10000$	200

Annex C

(informative)

Time-scales and epochs

C.1 Overview

A more detailed discussion of many of the topics in this annex can be found in Allan, Ashby, and Hodge [B1].

For historical reasons, time is specified in a variety of ways as listed in Table C.1. GPS, PTP, and TAI times are based on values yielded by atomic clocks and advance on each second. NTP and UTC times are similar, but are occasionally adjusted by one leap second, to account for differences between the atomic clocks and the rotation time of the earth.

Table C.1—Time-scale parameters

Parameter	Time scale				
	GPS	PTP	TAI	NTP	UTC
approximate epoch [†]	1980-01-06 1999-08-22	1970-01-01	no epoch defined	1900-01-01	no epoch defined
representation	weeks.seconds	seconds	YYYY-MM-DD hh:mm:ss	seconds	YYYY-MM-DD hh:mm:ss
rollover (years)	19.7	≈8 900 000	10 000	≈136	10 000
leapSeconds	no			yes	
NOTE 1—After 1972-01-01 00:00:00 TAI, TAI and UTC differ by only integer seconds.					
NOTE 2—The following represent the same instant in time: 1958-01-01 00:00:00 TAI and 1958-01-01 00:00:00 UTC					

Legend:

- [†] Each approximate epoch occurs at 00:00:00 on the respective date
- GPS global positioning satellite
- NTP Network Time Protocol
- PTP Precision Time Protocol
- TAI International Atomic Time (from the French term *Temps Atomique International*)
- UTC Coordinated Universal Time (the acronym is a compromise between the English term *coordinated universal time* and the French term *temps universel coordonné*
English speakers wanted the initials of their language: CUT for *coordinated universal time*
French speakers wanted the initials of their language: TUC for *temps universel coordonné*)

C.2 TAI and UTC

TAI and UTC are international standards for time based on the SI second as realized on the rotating geoid; (see ITU-R TF.460-6 [B12] and *The International System of Units (SI)* [B18] for the definitions of TAI and UTC, *The International System of Units (SI)* [B18] for the SI second, and Jekeli [B14] for more information on the rotating geoid). TAI is implemented by a suite of atomic clocks and forms the timekeeping basis for other time scales in common use. The rate at which UTC time advances is normally identical to the rate of TAI. An exception is an occasion when UTC is modified by adding or subtracting exactly one whole leap second.

The TAI and UTC timescales were introduced as of 1958-01-01, and the times 1958-01-01 00:00:00 TAI and 1958-01-01 00:00:00 UTC represent the same instant in time. However, this instant in time is not an epoch for TAI and UTC. An epoch, in the sense of the origin of a timescale (see 8.2.2), is not defined for either TAI or UTC. TAI and UTC are expressed in the form YYYY-MM-DD hh:mm:ss, rather than as elapsed time since an epoch; here, YYYY-MM-DD denotes the date and hh:mm:ss denotes the time in each day.

Prior to 1972-01-01, corrections to the offset between UTC and TAI were made by applying fractional-second corrections to UTC and corrections to the rate at which UTC advanced relative to the rate at which TAI advanced. After 1972-01-01, leap-second corrections are applied to UTC by inserting or deleting second(s) at the end of the last minute of preferably the last day of June or December. Also after 1972-01-01, UTC and TAI advance at the same rate. As of 2006-01-01, TAI and UTC times differed by +33 s (i.e., TAI time minus UTC time equals +33 s for 2006-01-01).

In POSIX-based computer systems, the common time conversion algorithms can produce the correct ISO 8601:2004 [B8] printed representation format “YYYY-MM-DD hh:mm:ss” for both TAI and UTC. ISO 8601:2004 specifies that the seconds of each minute are numbered from 00 to 59. A leap second added to the end of a minute is numbered 60. A second is deleted from the end of a minute by deleting the second labeled 59.

The PTP epoch is set such that a direct application of the POSIX algorithm to a PTP time-scale timestamp yields the ISO 8601:2004 printed representation of TAI. Subtracting the current *leapSeconds* value from a timestamp prior to applying the POSIX algorithm yields the ISO 8601:2004 printed representation of UTC. Conversely, applying the inverse POSIX algorithm and adding *leapSeconds* converts from the ISO 8601:2004 printed form of UTC to the form convenient for generating a timestamp.

Example: The POSIX algorithm applied to a timestamp value of 8 seconds yields 1970-01-01 00:00:08 (8 s after midnight on 1970-01-01 TAI). At this time the value of *leapSeconds* was approximately 8 s. Subtracting this 8 s from this time yields 1970-01-01 00:00:00 UTC.

Example: The POSIX algorithm applied to a timestamp value of 0 s yields 1970-01-01 00:00:00 TAI. At this time the value of *leapSeconds* was approximately 8 s. Subtracting this 8 s from this time yields 1969-12-31 23:59:52 UTC.

C.3 NTP and GPS

Two standard time sources of particular interest in implementing PTP systems: NTP and GPS. Both NTP and GPS systems are expected to provide time references for calibration of the grand-master supplied PTP time.

NTP represents seconds as a 32-bit unsigned integer that rolls-over every $2^{32} \text{ s} \approx 136$ year, with the first such rollover occurring in the year 2036. The precision of NTP systems is usually in the millisecond range.

NTP is a widely used protocol for synchronizing computer systems. NTP is based on sets of servers, to which NTP clients synchronize. These servers themselves are synchronized to time servers that are traceable to international standards.

NTP provides the current time in NTP version 4, the current *leapSeconds* value, and warning flags indicating that a *leapSecond* will be inserted at the end of the current UTC day. The NTP clock effectively stops for one second when the leap second is inserted.

GPS time comes from a global positioning satellite system, GPS, maintained by the U.S. Department of Defense. The precision of GPS system is usually in the 10 ns to 100 ns range. GPS system transmissions

represent the time as $\{weeks, secondsInWeek\}$, the number of weeks since the GPS epoch and the number of seconds since the beginning of the current week.

GPS also provides the current *leapSeconds* value, and warning flags marking the introduction of a leap second correction. UTC and TAI times can be computed solely based the information contained in the GPS transmissions.

GPS timing receivers generally manage the epoch transitions (1024-week rollovers), providing the correct time (YYYY-MM-DD hh:mm:ss) in TAI and/or UTC time scales, and often also local time; in addition to providing the raw GPS week, second of week, and leap-second information.

C.4 Time-scale conversions

Previously discussed representations of time can be readily converted to/from PTP *time* based on a constant offset and the distributed *leapSeconds* value, as specified in Table C.2. Within Table C.2, all variables represent integers; “/” and “%” represent a integer divide and remainder operation, respectively.

Table C.2—Time-scale conversions

ta		PTP value tb
Name	Format	
GPS	weeks:seconds	$tb = ta.seconds + 315\,964\,819 + (gpsRollovers * 1024 + ta.weeks) * (7 * DAYSECS);$
		$ta.weeks = (tb - 315\,964\,819) / (7 * DAYSECS) - gpsRollovers * 1024;$ $ta.seconds = (tb - 315\,964\,819) \% (7 * DAYSECS);$
TAI	date {YYYY,MM,DD} :time {hh,mm,ss}	$tb = DateToDays("1970-01-01", ta.date) * DAYSECS + ((ta.time.hh * 24) + ta.time.mm) * 60 + ta.time.ss;$
		$secs = tb \% DAYSECS;$ $ta.date = DaysToDate("1970-01-01", tb / DAYSECS);$ $ta.time.hh = secs / 3600;$ $ta.time.mm = (secs \% 3600) / 60;$ $ta.time.ss = (secs \% 60);$
NTP	seconds	$tb = (ta + leapSeconds) - 2\,208\,988\,800;$
		$ta = (tb - leapSeconds) + 2\,208\,988\,800;$
UTC	date {YYYY,MM,DD} :time {hh,mm,ss}	$tb = DateToDays("1970-01-01", ta.date) * DAYSECS + ((ta.time.hh * 24) + ta.time.mm) * 60 + ta.time.ss + leapSeconds;$
		$tc = tb - leapSeconds;$ $secs = tc \% DAYSECS;$ $ta.date = DaysToDate("1970-01-01", tc / DAYSECS);$ $ta.time.hh = secs / 3600;$ $ta.time.mm = (secs \% 3600) / 60;$ $ta.time.ss = (secs \% 60);$
NOTE— <i>gpsRollovers</i> Currently equals 1; changed from 0 to 1 between 1999-08-15 and 1999-08-22. <i>DAYSECS</i> The number of seconds within a day: (60*60*24). <i>leapSeconds</i> Extra seconds to account for variations in the earth-rotation times: 33 on 2006-01-01. <i>DateToDays</i> For arguments <i>DateToDays(past, present)</i> , returns days between <i>past</i> and <i>present</i> dates. <i>DaysToDate</i> For arguments <i>DaysToDate(past, days)</i> , returns the current date, <i>days</i> after the <i>past</i> date.		

C.5 Time zones and GMT

The term Greenwich Mean Time (GMT) once referred to mean solar time at the Royal Observatory in Greenwich, England. GMT now commonly refers to the time scale UTC; or the UK winter time zone (Western European Time, WET). Such GMT references are, strictly speaking, incorrect but nevertheless quite common. The following representations correspond to the same instant of time:

18:07:00 (GMT), commonplace usage	13:07:00 (Eastern Standard Time, EST)
18:07:00 (UTC)	01:07 PM (Eastern Standard Time, EST)
18:07:00 (Western European Time, WET)	10:07:00 (Pacific Standard Time, PST)
06:07 PM (Western European Time, WET)	10:07 AM (Pacific Standard Time, PST)

Annex D

(normative)

State diagram notation

State diagrams are used to represent the operation of the protocol by a number of cooperating state machines each comprising a group of connected, mutually exclusive states. Only one state of each machine can be active at any given time. Each state is represented in the state diagram as a rectangular box, divided into two parts by a horizontal line. The upper part contains the state identifier, written in upper case letters. The lower part, the state block, contains procedures that are executed on entry to the state.

All permissible transitions between states are represented by arrows, the arrowhead denoting the direction of the possible transition. Labels attached to arrows denote the condition(s) that must be met in order for the transition to take place. All conditions are expressions that evaluate to TRUE or FALSE; if a condition evaluates to TRUE, then the condition is met. The label UCT denotes an unconditional transition (i.e., UCT always evaluates to TRUE). A transition that is global in nature (i.e., a transition that occurs from any of the possible states if the condition attached to the arrow is met) is denoted by an open arrow (i.e., no specific state is identified as the origin of the transition). When the condition associated with a global transition is met, it supersedes all other exit conditions including UCT. The special global condition BEGIN supersedes all other global conditions. Once BEGIN is asserted it remains asserted, and completion of each state block is followed by reentry to that state, until all state blocks have executed to the point that variable assignments and other consequences of their execution remain unchanged.

On entry to a state, the procedures defined for the state (if any) are executed exactly once, in the order that they appear on the page. Each action is deemed to be atomic, i.e., execution of a procedure completes before the next sequential procedure starts to execute. The procedures in only one state block execute at a time, even if the conditions for execution of state blocks in different state machines are satisfied, and all procedures in an executing state block complete execution before the transition to and execution of any other state block occurs, i.e., the execution of any state block appears to be atomic with respect to the execution of any other state block and the transition condition to that state from the previous state is TRUE when execution commences. The order of execution of state blocks in different state machines is undefined except as constrained by their transition conditions. A variable that is set to a particular value in a state block retains that value until a subsequent state block modifies the value.

On completion of all of the procedures within a state, all exit conditions for the state (including all conditions associated with global transitions) are evaluated continuously until one of the conditions is met. The label ELSE denotes a transition that occurs if none of the other conditions for transitions from the state are met (i.e., ELSE evaluates to TRUE if all other possible exit conditions from the state evaluate to FALSE). Where two or more exit conditions with the same level of precedence become TRUE simultaneously, the choice as to which exit condition causes the state transition to take place is arbitrary. A UCT has the lowest level of precedence.

Where it is necessary to split a state machine description across more than one diagram, a transition between two states that appear on different diagrams is represented by an exit arrow drawn with dashed lines, plus a reference to the diagram that contains the destination state. Similarly, dashed arrows and a dashed state box are used on the destination diagram to show the transition to the destination state. In a state machine that has been split in this way, any global transitions that can cause entry to states defined in one of the diagrams are deemed to be potential exit conditions for all of the states of the state machine, regardless of which diagram the state boxes appear in.

Should a conflict exist between the interpretation of a state diagram and the textual description associated with the state machine, the state diagram takes precedence. The interpretation of the special symbols and

operators used in the state diagrams is as defined in Table D.1; these symbols and operators are derived from the notation of the “C++” programming language, ISO/IEC 14882:2003 [B11]. If a Boolean variable is described in this clause as being set, it has or is assigned the value TRUE; if reset or clear, the value FALSE.

Table D.1—State machine symbols

Symbol	Interpretation
()	Used to force the precedence of operators in Boolean expressions and to delimit the argument(s) of actions within state boxes.
;	Used as a terminating delimiter for actions within state boxes. Where a state box contains multiple actions, the order of execution follows the normal English language conventions for reading text.
=	Assignment action. The value of the expression to the right of the operator is assigned to the variable to the left of the operator. Where this operator is used to define multiple assignments, e.g., a = b = X the action causes the value of the expression following the right-most assignment operator to be assigned to all of the variables that appear to the left of the right-most assignment operator.
!	Logical NOT operator.
&&	Logical AND operator.
	Logical OR operator.
if...then...	Conditional action. If the Boolean expression following the if evaluates to TRUE, then the action following the then is executed.
{statement 1, ... statement N}	Compound statement. Braces are used to group statements that are executed together as if they were a single statement.
!=	Inequality. Evaluates to TRUE if the expression to the left of the operator is not equal in value to the expression to the right.
==	Equality. Evaluates to TRUE if the expression to the left of the operator is equal in value to the expression to the right.
<	Less than. Evaluates to TRUE if the value of the expression to the left of the operator is less than the value of the expression to the right.
>	Greater than. Evaluates to TRUE if the value of the expression to the left of the operator is greater than the value of the expression to the right.
>=	Greater than or equal to. Evaluates to TRUE if the value of the expression to the left of the operator is either greater than or equal to the value of the expression to the right.
+	Arithmetic addition operator.
-	Arithmetic subtraction operator.

Annex E

(normative)

Media-dependent layer specification for CSN Network

E.1 Overview

Accurate synchronized time is distributed throughout a gPTP domain through time measurements between adjacent time-aware Bridges or end stations in a bridged LAN. Time is communicated from the root of the clock spanning tree (i.e., the grandmaster) toward the leaves of the tree (i.e., from leaf-facing “master” ports to root-facing “slave” ports) through measurements made across the links connecting the time-aware systems. While the semantics of time transfer are consistent across the time-aware bridged LAN, the method for communicating synchronized time from a master station to its immediate downstream link partner varies depending on the type of link interconnecting the two time-aware systems.

This appendix specifies the protocol that provides accurate synchronized time across links of a *coordinated shared network* (CSN) as part of a bridged LAN.

E.2 Coordinated Shared Network characteristics

A CSN is a contention-free, time-division, multiplexed-access network of devices sharing a common medium and supporting reserved bandwidth based on priority or flow (QoS). One of the nodes of the CSN acts as the network coordinator, granting transmission opportunities to the other nodes of the network. A CSN network physically is a shared medium, in that a CSN node has a single physical port connected to the half-duplex medium, but is logically a fully connected one-hop mesh network, in that every node can transmit frames to every other node over the shared medium.

A CSN supports two types of transmission: unicast transmission for point-to-point (node-to-node) transmission and multicast/broadcast transmission for point-to-multipoint (node-to-other/all-nodes) transmission. Figure E.1 illustrates a CSN network acting as a backbone for time-aware systems.

NOTE—In this annex, the term *node* is used to refer to a CSN node (i.e., it does not refer to a time-aware Bridge or end station). A CSN node is a 2-port Bridge that forwards data packets between a segment external to the CSN (which may connect to an upstream or downstream time-aware system or Bridge) and the CSN network, all at the data link layer.

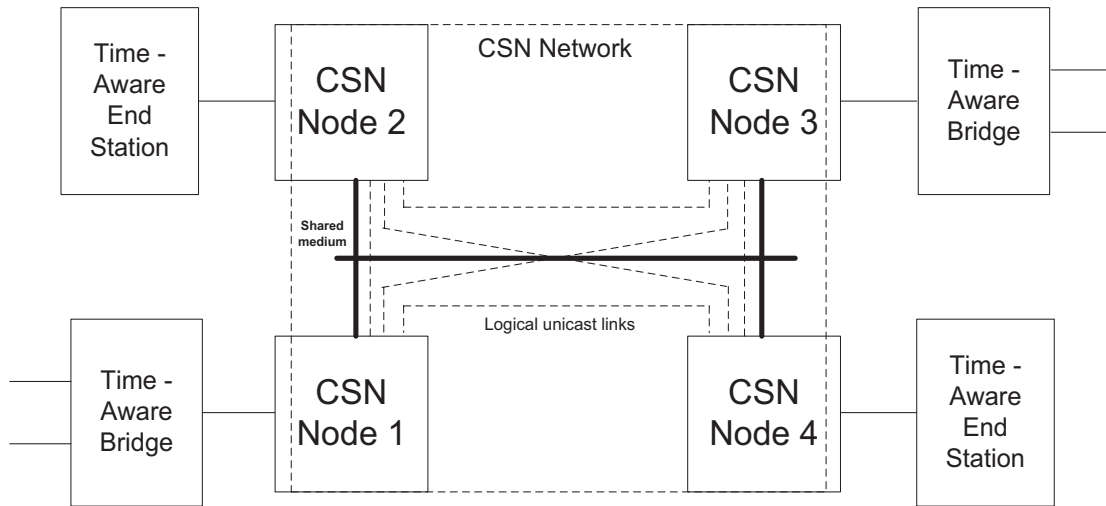

Figure E.1—Example of CSN backbone in an AVB LAN

E.3 Layering for CSN links

One PortSync entity and one MD entity are together associated with each CSN logical port (node-to-node link) as illustrated in Figure E.2. The PortSync entities is described in 10.1.1. The MD entity translates media-independent primitives to MD primitives as necessary for communicating synchronized time over the CSN links. The CSN MD entity shall implement the MDSyncSendSM and MDSyncReceiveSM states machines of 11.2.13 and 11.2.14.

The CSN MD entity either implements the MDPdelayReq and MDPdelayResp state machines of 11.2.15 and 11.2.16.2 to measure the propagation delay on a CSN link, or measures it through a CSN-native method and populates the variables described in E.4.3.2.

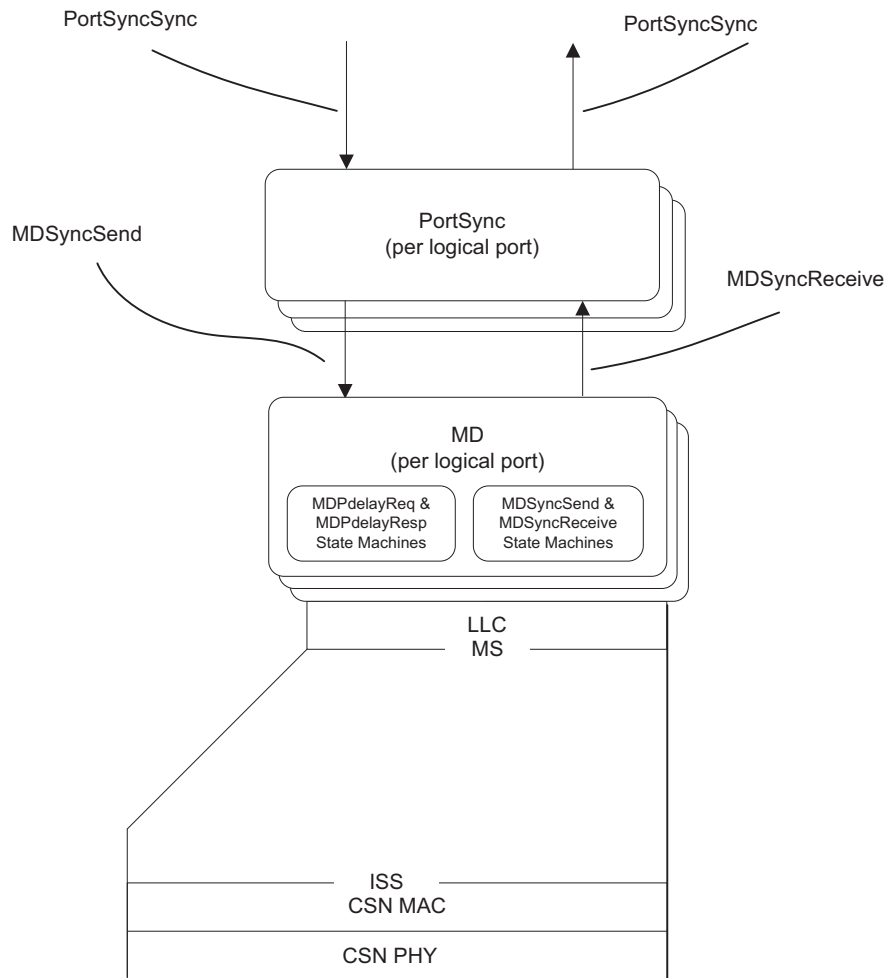

Figure E.2—Media-dependent and lower entities in CSN nodes

E.4 Path delay measurement over a CSN backbone

E.4.1 General

The Path Delay over a CSN backbone is calculated for the following path types: (1) between the upstream time-aware Bridge and the ingress CSN node, (2) between the ingress and egress CSN nodes, and (3) between the egress CSN node and the downstream time-aware system (Bridge or end station).

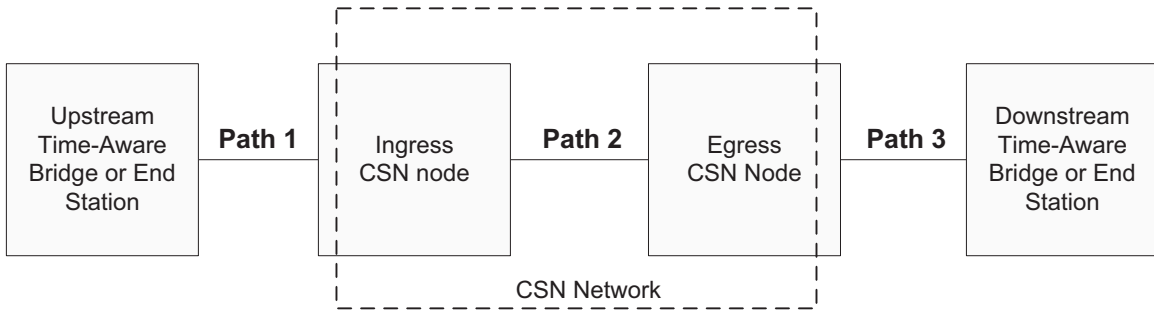

Figure E.3—Path types over CSN as IEEE 802.1AS backbone

To maintain the synchronization, residence time on each node and the propagation delay between nodes is measured, requiring precise timestamping on both CSN node ingress and egress ports as illustrated in Figure E.4 (“Path *i*” in the figure refers to the paths enumerated in Figure E.3). In Figure E.4, ti_1 is the `<syncEventEgressTimestamp>` for the Sync message at the upstream time-aware Bridge, ti_2 is the `<syncEventIngressTimestamp>` for the Sync message at the ingress CSN time-aware Bridge, te_1 is the `<syncEventEgressTimestamp>` for the Sync message at the egress CSN time-aware Bridge, and te_2 is the `<syncEventIngressTimestamp>` for the Sync message at the downstream time-aware Bridge or end-station.

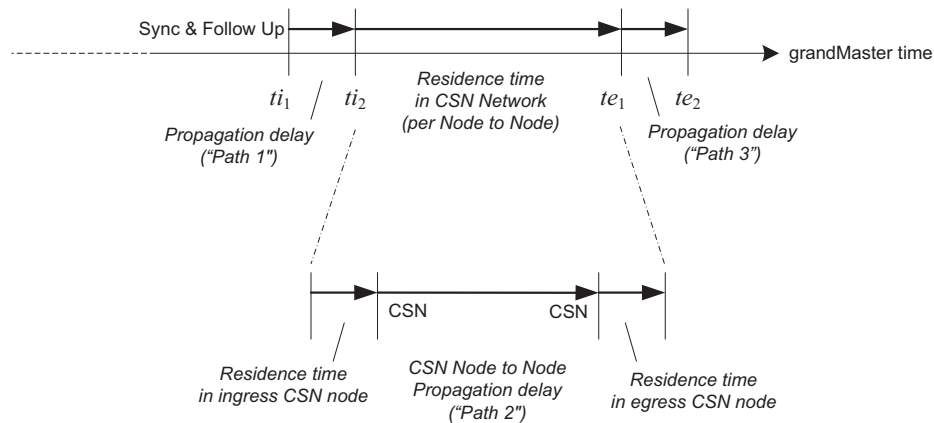

Figure E.4—Propagation delay and residence time over a CSN Backbone

E.4.2 Path delay measurement between CSN node and neighbor time-aware system

The path delay measurement between a CSN node and a neighbor time-aware system is made as specified for the respective medium. This path delay measurement is made for the link between the CSN node and the neighbor time-aware system.

E.4.3 Path delay measurement between CSN nodes

The path delay between the two nodes of a CSN is the propagation delay for the logical link that connects those two nodes. The method of measuring the path delay between two CSN nodes has two variations which are described in E.4.3.1 and E.4.3.2, respectively. The specific method to be used for a specific link technology is specified in E.6.

E.4.3.1 Path delay measurement without network clock reference

Each CSN node has a free-running local clock. The path delay measurement uses the protocol, messages, and state machines described in Clause 11 for full-duplex, point-to-point links, as illustrated by Figure E.5.

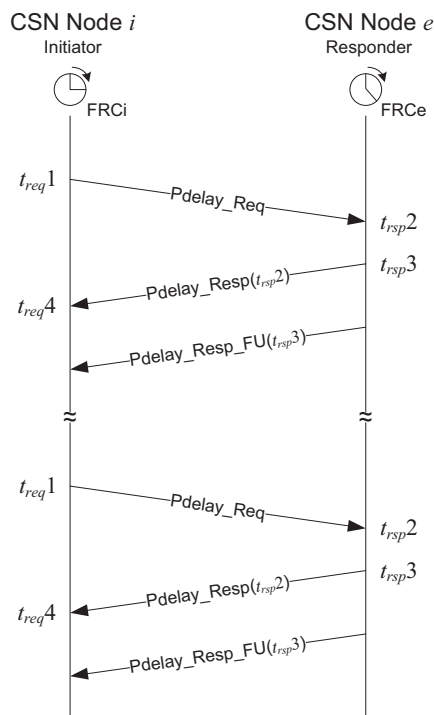

Figure E.5—CSN node-to-node path delay measurement

The computation of the `neighborRateRatio` and `neighborPropDelay` between two CSN nodes is done using the timestamps at the initiator and information conveyed in the successive `Pdelay_Resp` and `Pdelay_Resp_Follow_Up` messages. Any scheme that uses this information is acceptable, as long as the performance requirements of B.2.4 are met. As one example, the `neighborRateRatio` is computed as the ratio between a time interval measured by the local clock of the responder and its associated time interval measured by the local clock of the initiator, using a set of received `Pdelay_Resp` and `Pdelay_Resp_Follow_Up` messages and a second set of received `Pdelay_Resp` and

Pdelay_Resp_Follow_Up messages some number of Pdelay_Req message transmission intervals later, i.e., as show in Equation (E.1):

$$\frac{(t_{rsp3})_N - (t_{rsp3})_0}{(t_{req4})_N - (t_{req4})_0} \quad (\text{E.1})$$

where $(t_{rsp3})_k$ is the time relative to the local clock of the responder that the k^{th} Pdelay_Resp message is sent, $(t_{req4})_k$ is the time relative to the local clock of the initiator that the k^{th} Pdelay_Resp message is received, N is the number of Pdelay_Req message transmission intervals separating the first set of received Pdelay_Resp and Pdelay_Resp_Follow_Up messages and the second set, and the successive sets of received Pdelay_Resp and Pdelay_Resp_Follow_Up messages are indexed from 0 to N with the first set indexed 0. The neighborPropDelay between the time-aware system and the CSN node is computed as shown in Equation (E.2):

$$\frac{(t_{req4} - t_{req1})r - (t_{rsp3} - t_{rsp2})}{2} \quad (\text{E.2})$$

where r is equal to neighborRateRatio, t_{req1} is the time relative to the local clock of the initiator that the Pdelay_Req message for this message exchange is sent, t_{rsp2} is the time relative to the local clock of the responder that the Pdelay_Req message for this message exchange is received, t_{rsp3} is the time relative to the local clock of the responder that the Pdelay_Resp message for this message exchange is sent, and t_{req4} is the time relative to the local clock of the initiator that the Pdelay_Resp message for this message exchange is received.

NOTE—The difference between mean propagation delay relative to the grandmaster time base and relative to the time base of the CSN node at the other end of the attached link (i.e., the responder CSN node) is usually negligible. To see this, note that the former can be obtained from the latter by multiplying the latter by the ratio of the grandmaster frequency to the frequency of the LocalClock entity of the CSN node at the other end of the link. This ratio differs from 1 by 200 ppm or less. For example, for a worst-case frequency offset of the LocalClock entity of the CSN node at the other end of the link, relative to the grandmaster, of 200 ppm, and a measured propagation time of 100 ns, the difference in mean propagation delay relative to the two time bases is 20 ps.

Although the propagation delay between two CSN nodes is constant, a Pdelay_Req message is still sent periodically by each node to each other active node of the network to measure the neighborRateRatio between the node and each other node. Each node shall implement the state machines described in 11.2.15 and 11.2.16.2.

E.4.3.2 Native CSN path delay measurement

Some CSN technologies feature a native mechanism that provides a path delay measurement with accuracy similar to the accuracy the peer delay protocol provides. For these CSNs, the path delay may be provided using the native measurement method rather than using the Pdelay protocol defined in 11.2.15 and 11.2.16.2. Such a situation is described in more detail as follows. The CSN MD entity populates the following per-port and MD entity global variables (described respectively in 10.2.4 and 11.2.12) as indicated:

- asCapable (10.2.4.1) is set to TRUE,
- neighborRateRatio (10.2.4.6) is set to the value provided by the native CSN measurement,
- neighborPropDelay (10.2.4.7) is set to the value provided by the native CSN measurement,
- computeNeighborRateRatio (10.2.4.9) is set to FALSE,
- computeNeighborPropDelay (10.2.4.10) is set to FALSE, and
- isMeasuringDelay (11.2.12.5) is set to TRUE to indicate that the CSN MD entity is measuring path delay (in this case, using its internal mechanism).

E.4.3.3 Intrinsic CSN path delay measurement

If the CSN network features a native mechanism that causes each node’s local clock to be fully synchronized to the local clocks of other nodes of the CSN such that the synchronized CSN time complies with the requirements specified in B.1, the CSN nodes need not implement the path delay mechanism but rather treat the path delay as part of the residence time of the distributed system. The propagation of the Sync messages in this case is described in E.5.2.

E.5 Synchronization messages

The CSN network shall propagate synchronized time over the CSN to CSN end stations and to downstream non-CSN links, using Sync (and associated Follow_Up) messages, as illustrated in Figure E.6.

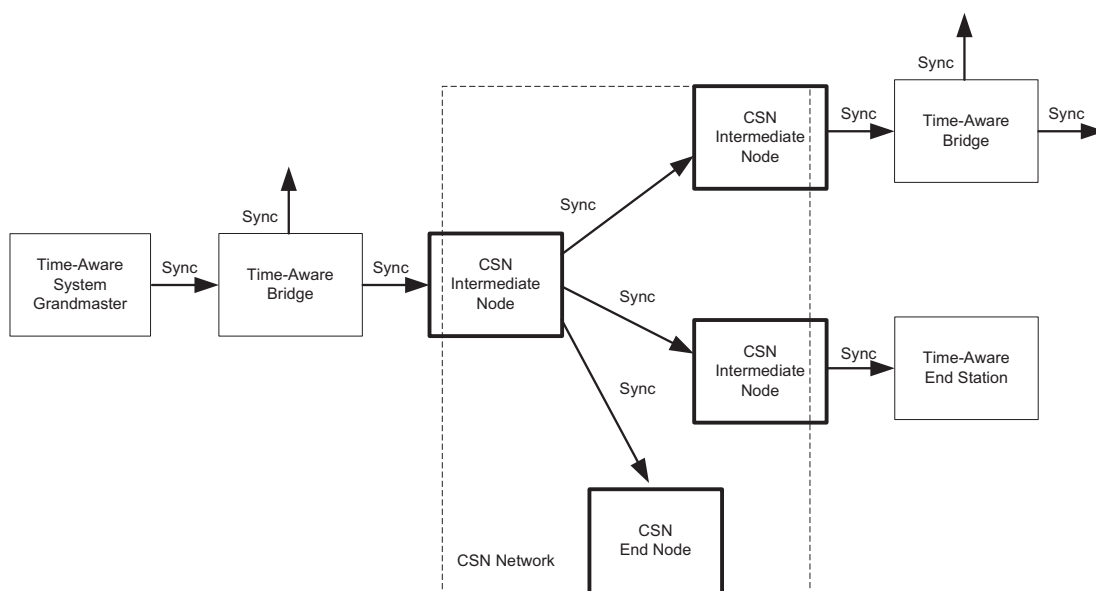

Figure E.6—IEEE 802.1AS Sync Message Propagation over the CSN backbone

Once the path delays have been measured (a) between the upstream time-aware Bridge and the ingress CSN node, (b) between the CSN nodes, and (c) between the egress CSN node and the downstream time-aware Bridge or end station, the CSN backbone can propagate the synchronization information received at its boundary nodes.

As with path delay measurements, various CSN technologies choose various methods for propagating time. These methods are described as follows.

E.5.1 Synchronization message propagation on CSN without network reference clock

If the CSN network does not feature a native mechanism that synchronizes the CSN node local clocks to each other or to a reference, such that the CSN synchronized time complies with the requirements specified in B.1, the CSN local clock at CSN ingress and CSN egress nodes are considered independent free running clocks.

In this case, synchronization over the CSN links uses the Sync and Follow_Up protocol, messages, and state machines specified for full-duplex point-to-point links in 10.2.7, 10.2.11, 11.2.13, and 11.2.14. Individual CSN link technologies may specify media-specific encapsulation of gPTP event messages. See Table E.2 for selection of options per link technology.

One PortSync and one MD entity is instantiated per logical port (i.e., per CSN link). A CSN node behaves equivalently to a time-aware system. Sync and Follow_Up messages are either transmitted using unicast on each link or broadcasted. However if Sync and Follow_Up messages are broadcasted:

- the Sync and Follow_Up messages are broadcast with the same port number used to broadcast Announce messages,
- all PortSync/MD entity pairs except one set their logSyncInterval attribute (see 10.6.2.3) to 127, causing them to not generate any Sync messages, and
- a dynamic selection of the MD entity that broadcasts the Sync message is needed (a CSN node can dynamically leave the CSN network). The dynamic selection algorithm is implementation specific and out of the scope of this standard.

E.5.2 Synchronization message propagation on a CSN with network reference clock

If the CSN network features a native mechanism that allows the CSN node's local clocks to be fully synchronized to each other in a way that complies with the requirements specified in B.1, it is possible to simplify the path delay mechanism, as described below. This method is an alternative to E.5.1. Individual CSN link technologies may specify media-specific encapsulation of gPTP event messages. See Table E.2 for selection of options per link technology.

Sync messages are timestamped (1) when received at the ingress CSN node's time-aware system port (<syncEventIngressTimestamp>) and (2) when transmitted at the egress CSN node's time-aware system port (<syncEventEgressTimestamp>). The elapsed time between the egress and ingress timestamps is computed as the CSN residence time. In this scheme, the Sync message handling is split between the MDSyncSendSM state machine in the CSN ingress node and the MDSyncReceiveSM state machine in the CSN egress node as described in E.5.2.1 and E.5.2.2.

The reference plane for a CSN port and the path delay measurement method are specific to the type of CSN technology, and are defined in Table E.2.

E.5.2.1 CSN ingress node

The CSN ingress node timestamps Sync messages received from the upstream time-aware system and compute the upstreamTxTime as described in 11.2.13.2.1, item f).

In addition, the setFollowUp function of the MDSyncSendSM state machine [see 11.2.14.2.3, item a)] is be modified as follows:

- a) The quantity $rateRatio \times (<syncEventEgressTimestamp - upstreamTxTime>)$ is not added to the followUpCorrectionField of the Follow_Up message to be transmitted by the ingress to the egress CSN node
- b) The CSN TLV (see E.5.2.1.1) is appended to the Follow_Up message transmitted by the ingress to the egress CSN node.

E.5.2.1.1 CSN TLV**E.5.2.1.1.1 General**

The fields of the CSN TLV are specified in Table E.1 and E.5.2.1.1.3 through E.5.2.1.1.7. This TLV is a standard organization extension TLV for the Follow_Up message, as specified in 14.3 of IEEE Std 1588-2008. This TLV is not allowed to occur before the Follow_Up information TLV (see 11.4.4.3).

Table E.1—CSN TLV

Bits								Octets	Offset From Start of TLV
8	7	6	5	4	3	2	1		
tlvType								2	0
lengthField								2	2
organizationId								3	4
organizationSubType								3	7
upstreamTxTime								12	10
neighborRateRatio								4	14
neighborPropDelay								12	26
delayAsymmetry								12	38

E.5.2.1.1.2 tlvType (Enumeration16)

The value of the tlvType field is 0x3.

NOTE—This is the value that indicates the TLV is a vendor and standard organization extension TLV, as specified in 14.3.2.1 of IEEE Std 1588-2008. The value is specified there as ORGANIZATION_EXTENSION, whose value is 0x3.

E.5.2.1.1.3 lengthField (UInteger16)

The value of the length is 46.

E.5.2.1.1.4 organizationId (Octet3)

The value of organizationId is 00-80-C2.

E.5.2.1.1.5 organizationSubType (Enumeration24)

The value of organizationSubType is 3.

E.5.2.1.1.6 upstreamTxTime (UScaledNs)

The computed upstreamTxTime value as described in 11.2.13.2.1 item f).

E.5.2.1.1.7 neighborRateRatio (Integer32)

The neighborRateRatio value described in 10.2.4.6.

E.5.2.1.1.8 neighborPropDelay (UScaledNs)

The neighborPropDelay value described in 10.2.4.7.

E.5.2.1.1.9 delayAsymmetry (UScaledNs)

The delayAsymmetry value described in 10.2.4.8.

E.5.2.2 CSN egress node

The CSN egress port sets neighborRateRatio to 1 and neighborPropDelay to 0 for its CSN port.

The CSN egress port modifies the function setMDSyncReceive of the MDSyncReceiveSM state machine [11.2.13.2.1 item f)] for the port to CSN link entity to extract upstreamTxTime, neighborPropDelay, and neighborRateRatio from the respective fields of the CSN TLV in the Follow_Up message received from the CSN ingress node.

The CSN egress port also modifies the ClockSlaveSync state machine (see 10.2.12) to get the upstreamTxTime, neighborPropDelay, neighborRateRatio, and delayAsymmetry values from the respective fields of the CSN TLV in the Follow_Up message received from the CSN ingress node.

The CSN egress node removes the CSN TLV from the Follow_Up message it creates and transmits to the downstream time-aware system.

E.6 Specific CSN requirements

The reference plane for a CSN port is specific to the type of CSN technology and is defined in Table E.2.

Table E.2—Definitions and option selections per link technology

CSN link technology	Reference plane	Path Delay measurement	gPTP event message encapsulation
Multimedia over Coax Alliance (MoCA) v2.0	The first bit of an Event message crossing to and from the MoCA CTC clock domain.	MoCA Ranging Protocol	Encapsulated in control frames as described in the MoCA MAC/PHY Specification v2.0.
ITU-T G.hn (SG15)	The first bit of an Event message crossing the A-interface. See E.6.2.	Pdelay mechanism as defined in E.4.3.1.	None

E.6.1 MoCA-specific behavior

The MoCA network is a CSN. The non-MoCA port of a Bridge behaves as a time-aware system port, which might or might not use the MoCA CTC clock for timestamping event messages. If the non-MoCA port of the Bridge uses a different clock than the MoCA CTC clock, then the Bridge reconciles the non-CTC timestamp with the CTC time.

Sync messages shall be timestamped using the CTC clock (1) when the Sync message crosses the MoCA's ingress node's timestamp reference plane (<syncEventIngressTimestamp>) and (2) when it crosses the egress CSN node's reference plane (<syncEventEgressTimestamp>).

The elapsed time between the egress and ingress timestamps, <syncEventIngressTimestamp> – <syncEventEgressTimestamp>, is computed as the MoCA residence time.

The MoCA port whose port role is MasterPort propagates the Sync and Follow_Up messages as described in E.5.2. The CSN TLV values of the Follow_Up message sent over the MoCA network is computed using the LocalClock, i.e., the MoCA CTC clock.

IEEE 802.1 AS Frames shall be transmitted over the MoCA network as MoCA control frames as described in the MoCA MAC/PHY Specification v2.0.

NOTE—The Channel-Time Clock (CTC) is specified in the MoCA MAC/PHY Specification v2.0.

E.6.2 ITU-T G.hn-specific behavior

A port of a time-aware system that includes one or more ITU-T G.hn ports shall behave as defined in E.3, E.4, and E.5, but for aspects where more than one behavior or option is described, the system behaves as defined in Table E.2.

ITU-T G.hn defines a 32-bit timestamp (which is placed in the TSMP field of a G.hn encapsulation header). This timestamp, as described in Table E.2, is captured each time an Event message is transmitted or received by an ITU-T G.hn port and is used for all gPTP event messages, including SYNC and PDELAY messages.

E.7 Grandmaster capability

Each CSN Node may be grandmaster capable, allowing a CSN node to act as the grandmaster clock either for a homogeneous CSN network or for a heterogeneous network.

The Announce messages are either sent via unicast on each link or broadcasted. However if Announce messages are broadcasted, the Announce message shall use the same port number as used by the Sync and Follow_Up messages by a single PortSync/MD entity pair on the port. This is accomplished by setting the logAnnounceInterval attribute (see 10.6.2.2) to 127 for all but one PortSync/MD entity pair, causing them to not generate any Announce messages.

E.8 CSN clock and node requirements

The CSN clock performance shall comply with the requirements specified in B.1. The CSN node performance shall comply with the requirements specified in B.2.2, B.2.3, and B.2.4.

Annex F

(informative)

PTP profile included in this standard

The specification in this standard of synchronized time transport over a full-duplex, point-to-point link includes a PTP profile. The information contained in a PTP profile is described in 19.3 of IEEE Std 1588-2008. This annex summarizes the PTP profile for transport of timing over full-duplex, point-to-point links. This PTP profile is also used in the transport of timing over CSN for the case where a CSN network clock reference is not present (see Annex E). This PTP profile is not used in the transport of timing over IEEE 802.11 links and IEEE 802.3 EPON links; both these transports use native timing mechanisms to assist in the synchronized time transport.

F.1 Identification

The identification values for this PTP profile (see 19.3.3 of IEEE Std 1588-2008) are as follows:

PTP Profile:
IEEE 802.1AS PTP profile for transport of timing over full-duplex, point-to-point links
Version 1.0
Profile identifier: 00-80-C2-00-01-00

This profile is specified by the IEEE 802.1 Working Group of the IEEE 802 LAN/MAN Standards Committee.

A copy may be obtained by ordering IEEE Std 802.1AS-2011 from the IEEE Standards Organization.¹⁸

F.2 PTP attribute values

The ranges and default values for time-aware system attributes covered by this profile are as follows:

- a) The domain number is 0 (see 8.1).
- b) The default logAnnounceInterval (see 10.6.2.2) is 0. The value 127 is supported.
- c) The default logSyncInterval (see 11.5.2.3) is -3. The value 127 is supported.
- d) The default logPdelayReqInterval (see 11.5.2.2) is 0. The value 127 is supported.
- e) The default announceReceiptTimeout (see 10.6.3.2) is 3.
- f) The default values of priority1, for different media, are specified in 8.6.2.1, Table 8-2. The value of priority1 for a time-aware system that is not grandmaster-capable is 255.
- g) The default value of priority2 is 248 (see 8.6.2.5).
- h) The default observation interval for offsetScaledLogVariance is equal to the default sync interval, i.e., 0.125 s (see 8.6.2.4).

F.3 PTP options

- a) The best master clock algorithm is the alternate BMCA specified in 10.3.

¹⁸IEEE publications are available from the Institute of Electrical and Electronics Engineers, 445 Hoes Lane, Piscataway, NJ 08854, USA (<http://standards.ieee.org>).

NOTE—This BMCA is similar, but not identical, to the default BMCA described in IEEE Std 1588-2008. The main differences are (1) Announce information from a potential best master is used immediately, i.e., there is no notion of foreign master qualification, and (2) a port whose port role is determined by the BMCA to be MasterPort has its port role changed to MasterPort immediately, i.e., there is no “PreMasterPortRole.”

- b) The management mechanism is the mechanism specified in Clause 14 and Clause 15.
- c) The path delay mechanism is the peer delay mechanism (see Clause 11).
- d) The transport mechanism is full-duplex, point-to-point, and uses attribute values described in Annex F of IEEE Std 1588-2008 for IEEE 802.3 Ethernet. Specifically, the address, Ethertype, and subtype are specified in 11.3.4, 11.3.5, and 11.3.6.
- e) A time-aware system that contains one PortSync and one MD entity is an ordinary clock. A time-aware system that contains more than one PortSync and more than one MD entity is a boundary clock. All time-aware systems are two-step clocks.
- f) Each port of a time-aware system measures the frequency offset of its neighbor, at the other end of the attached link, relative to itself (see Clause 11). The frequency offset, relative to the grandmaster, is accumulated in a standard organization TLV that is attached to the Follow_Up message (see 11.4.4.3). The standard organization TLV also carries information on grandmaster traceability and phase and frequency change due to the most recent grandmaster change. The physical adjustment of the frequency of the LocalClock entity (i.e., physical syntonization) is allowed but not required.
- g) The path trace feature of 16.2 of IEEE Std 1588-2008 is used (see 10.5.3.2.8).
- h) A standard organization TLV is defined that allows a port of a time-aware system to request that its neighbor slow down or speed up the rate at which it sends Sync/Follow_Up, peer delay, and/or Announce messages (see 10.5.4.3)
- i) The acceptable master table feature of IEEE Std 1588-2008 is used with IEEE 802.3 EPON links to ensure that the OLT is master and ONUs are slaves.

NOTE—This feature is used with EPON links, and therefore could be considered to be outside the PTP profile (because EPON links are part of the PTP profile). It is included here because it is one of the optional features described in IEEE Std 1588-2008.

- j) Except for items g) and i) above, the optional features of Clause 16 and Clause 17 of IEEE Std 1588-2008 are not used.
- k) The experimental security protocol of Annex K of IEEE Std 1588-2008 is not used.
- l) The cumulative frequency scale factor of Annex L of IEEE Std 1588-2008 is not used, but cumulative frequency offset relative to the grandmaster is accumulated in a TLV, and is encoded in the same way as the cumulative frequency scale factor in Annex L of IEEE Std 1588-2008.

F.4 LocalClock and time-aware system performance requirements

The LocalClock performance requirements are as specified in B.1. The time-aware system performance requirements are as specified in B.2.

Annex G

(informative)

Bibliography

[B1] Allan, David W., Ashby, Neil, and Hodge, Clifford C., “The Science of Timekeeping,” Hewlett Packard Application Note 1289, 1997.¹⁹

[B2] IEEE EUI-64, IEEE EUI-48, and IEEE MAC-48 assigned numbers may be obtained from the IEEE Registration Authority.²⁰

[B3] IEEE P802.1Qbb™ (D2.3, May 2010), Draft Standard for Local and Metropolitan Area Networks—Virtual Bridged Local Area Networks—Amendment: Priority-based Flow Control.²¹

[B4] IEEE Std 802®[®], IEEE Standard for Local and Metropolitan Area Networks—Overview and Architecture.

[B5] IEEE Std 802.1X™-2010, IEEE Standard for Local and Metropolitan Area Networks—Port-Based Network Access Control.^{22, 23}

[B6] IEEE Std 1139™-1999, IEEE Standard Definitions of Physical Quantities for Fundamental Frequency and Time Metrology—Random Instabilities.

[B7] IEEE Std 1003.1™-2008, IEEE Standard for Information Technology—Portable Operating System Interface (POSIX™) Base Specifications, Issue 7.

[B8] ISO 8601:2004, Data elements and interchange formats—Information interchange—Representation of dates and times.²⁴

[B9] ISO/IEC 8802-2, Standard for Information technology—Telecommunications and information exchange between systems—Local and metropolitan area networks—Specific requirements—Part 2: Logical link control.

[B10] ISO/IEC 9945:2003, Information technology. Portable Operating System Interface (POSIX™).

[B11] ISO/IEC 14882:2003, Programming languages—C++.

[B12] ITU-R Recommendation TF.460-6, Standard-frequency and time-signal emissions, 2002.²⁵

¹⁹Available at http://www.allanstime.com/Publications/DWA/Science_Timekeeping/TheScienceOfTimekeeping.pdf.

²⁰Available at <http://standards.ieee.org/regauth/>. Tutorials on these assigned numbers can be found on this Web site.

²¹Numbers preceded by P are IEEE authorized standards projects that were not approved by the IEEE-SA Standards Board at the time this publication went to press. For information about obtaining drafts, contact the IEEE.

²²IEEE publications are available from the Institute of Electrical and Electronics Engineers, 445 Hoes Lane, Piscataway, NJ 08854, USA (<http://standards.ieee.org>).

²³The IEEE standards or products referred to in Annex G are trademarks owned by the Institute of Electrical and Electronics Engineers, Incorporated.

²⁴ISO publications are available from the ISO Central Secretariat, 1, ch. de la Voie-Creuse, Case Postale 56, CH-1211, Geneva 20, Switzerland (<http://www.iso.org/>). IEC publications are available from the Central Office of the International Electrotechnical Commission, 3, rue de Varembe, P.O. Box 131, CH-1211, Geneva 20, Switzerland (<http://www.iec.ch/>). ISO/IEC publications are also available in the United States from the Sales Department, American National Standards Institute, 25 West 43rd Street, 4th Floor, New York, NY 10036, USA (<http://www.ansi.org/>).

²⁵ITU publications are available from the International Telecommunications Union, Place des Nations, CH-1211, Geneva 20, Switzerland/Suisse (<http://www.itu.int/>).

[B13] ITU-T Recommendation G.810, Definitions and Terminology for Synchronization Networks, ITU-T, Geneva, August, 1996, Corregendum 1, November, 2001.

[B14] Jekeli, Christopher, “Geometric Reference Systems in Geodesy,” Division of Geodesy and Geospatial Science, School of Earth Sciences, Ohio State University, July 2006.²⁶

[B15] MoCA MAC/PHY Specification v1.0, MoCA-M/P-SPEC-V1.0-07122009, Multimedia over Coax Alliance (MoCA), July 12, 2009.²⁷

[B16] MoCA MAC/PHY Specification Extensions v1.1, MoCA-M/P-SPEC-V1.1-06162009, Multimedia over Coax Alliance (MoCA), June 16, 2009.

[B17] Service de la rotation terrestre, Observatoire de Paris, 61, Av. de l’Observatoire 75014 Paris (France).

[B18] “The International System of Units (SI),” 8th edition, Bureau International des Poids et Mesures, 2006.²⁸

[B19] U.S. Naval Observatory.²⁹

²⁶Available at https://kb.osu.edu/dspace/bitstream/1811/24301/1/Geom_Ref_Sys_Geodesy.pdf.

²⁷MoCA specifications are available from the Multimedia over Coax Alliance at <http://www.mocalliance.org/specs>.

²⁸Available at http://www.bipm.org/en/si/si_brochure/.

²⁹Available at <http://maia.usno.navy.mil/ser7/tai-utc.dat>.