

Overview TUHH Object Oriented Languages Activities

- Modelling of energy systems components with the object oriented language *Smile* (1998, Georg **Mühlthaler**, now Airbus Germany)
- Modelling of domestic heating and warm water appliances with *TRNSYS* and the object oriented language *Smile* (2000, Bruno **Lüdemann**, now Imtech Germany and Ole **Engel**, now XRG Simulation)
- *ACLib* – Air Conditioning Library (2004, Torge **Pfafferott**, now Airbus Germany, precursor of *AirConditioning library*)
- *HKSim* - Simulation of Complex Energy System (2005, Stefan **Wischhusen**, now XRG Simulation GmbH, Hamburg)
- Katrin **Pröiß** (now Modelon) has made some contributions to *Modelica_Fluid*
- CABFlow - Cabin Flow (2009, Henning **Knigge**, now Vattenfall Europe, Andreas **Joos**)
- *ACCLIB* - AirConditioning and Cooling Systems in Aircrafts (still under construction, Karin **Dietl**, Jens **Vasel**, Cooling systems in aircrafts)
- Air conditioning library for building applications (still under construction, Wilson **Casas**, now Airbus Germany, Andreas **Joos**, Jan **Wrobel**)

- Desiccant cooling with using of geothermal energy (Jan Wrobel)
Financial sup.: BMWi, FHH, Imtech, Zenrumspfähle, Vattenfall, 1.4.08 -31.3.11, 1200 k€
- MOET WP4.25 cooling systems in aircrafts (Jens Vasel, Karin Dietl)
Financial sup.: European Union, 1.7.2006 – 31.12.09, 520 k€
- Battery cooling in mild hybrid cars (Imke Küger)
Financial sup.: DaimlerChrysler, 1.10.07 – 31.12.09, 220 k€
- Modelling of air cycles machines (Karin Dietl)
Financial sup.: Liebherr Toulouse (later European Union), 1.1.09 – 31.12.09, 100 k€
- ECOTHERM–Experimental investigations of aircraft cooling systems (Ekkehard Lohse)
Financial sup.: BMWi (LuFo 4) 1.1.09 – 31.12.11, 418 k€
- Mohicab – Modelling of the humidity transport in aircraft cabins (Andreas Joos)
Financial sup.: FHH, BMWi, Airbus, 1.1.08 – 31.12.10, 390 k€

Desiccant assisted air conditioning

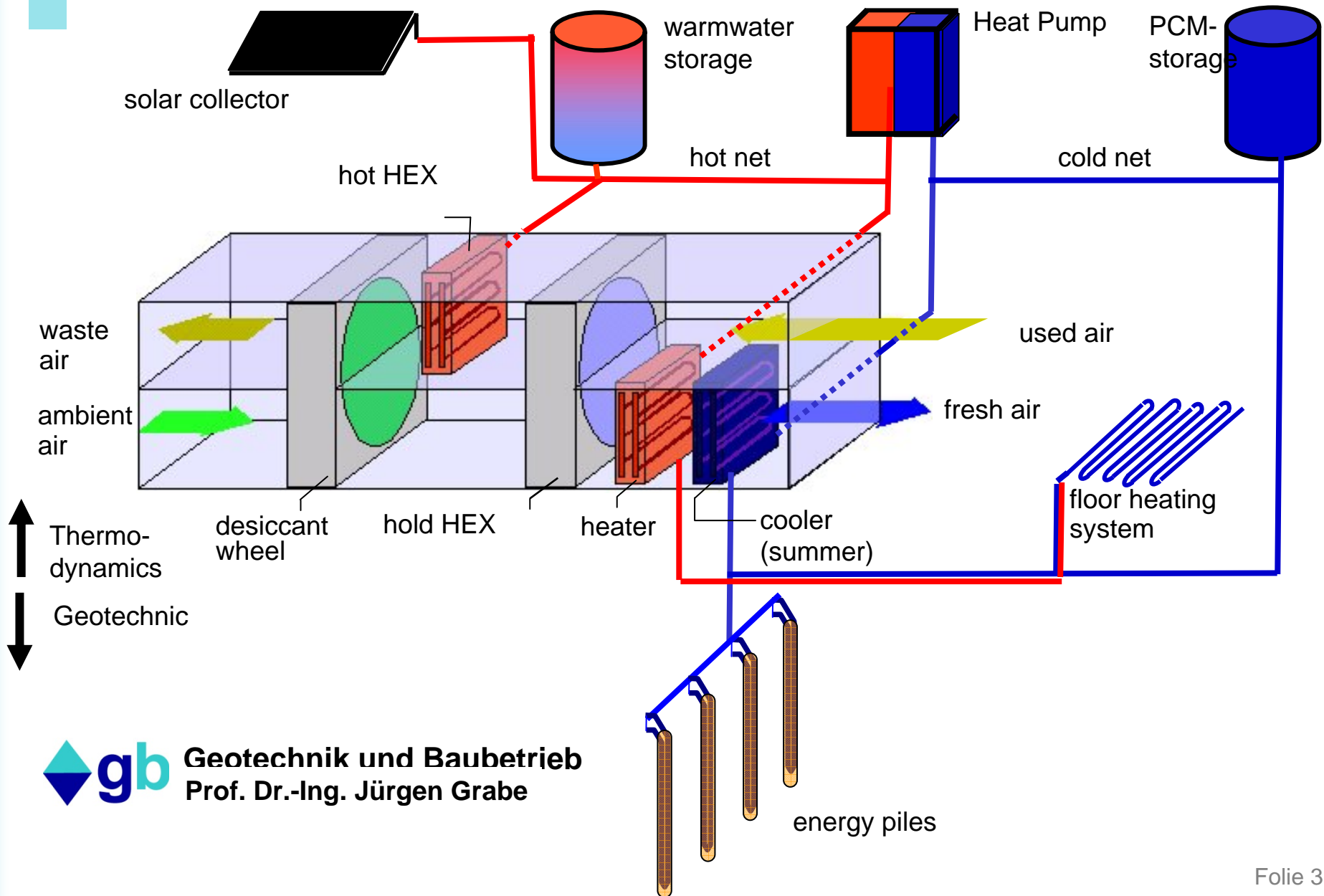

Cabin model in Modelica

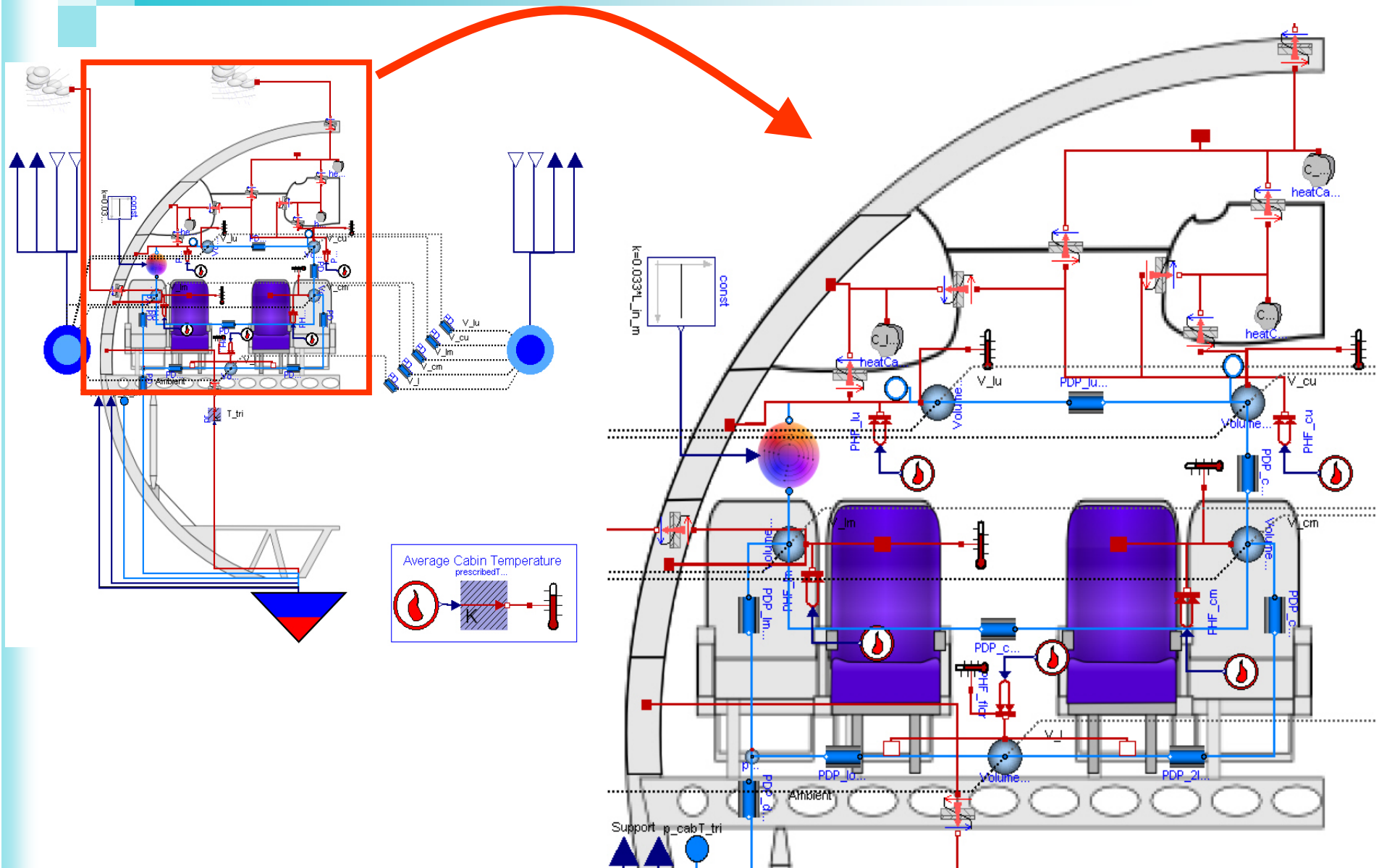

New Cooling Architectures in Aircrafts

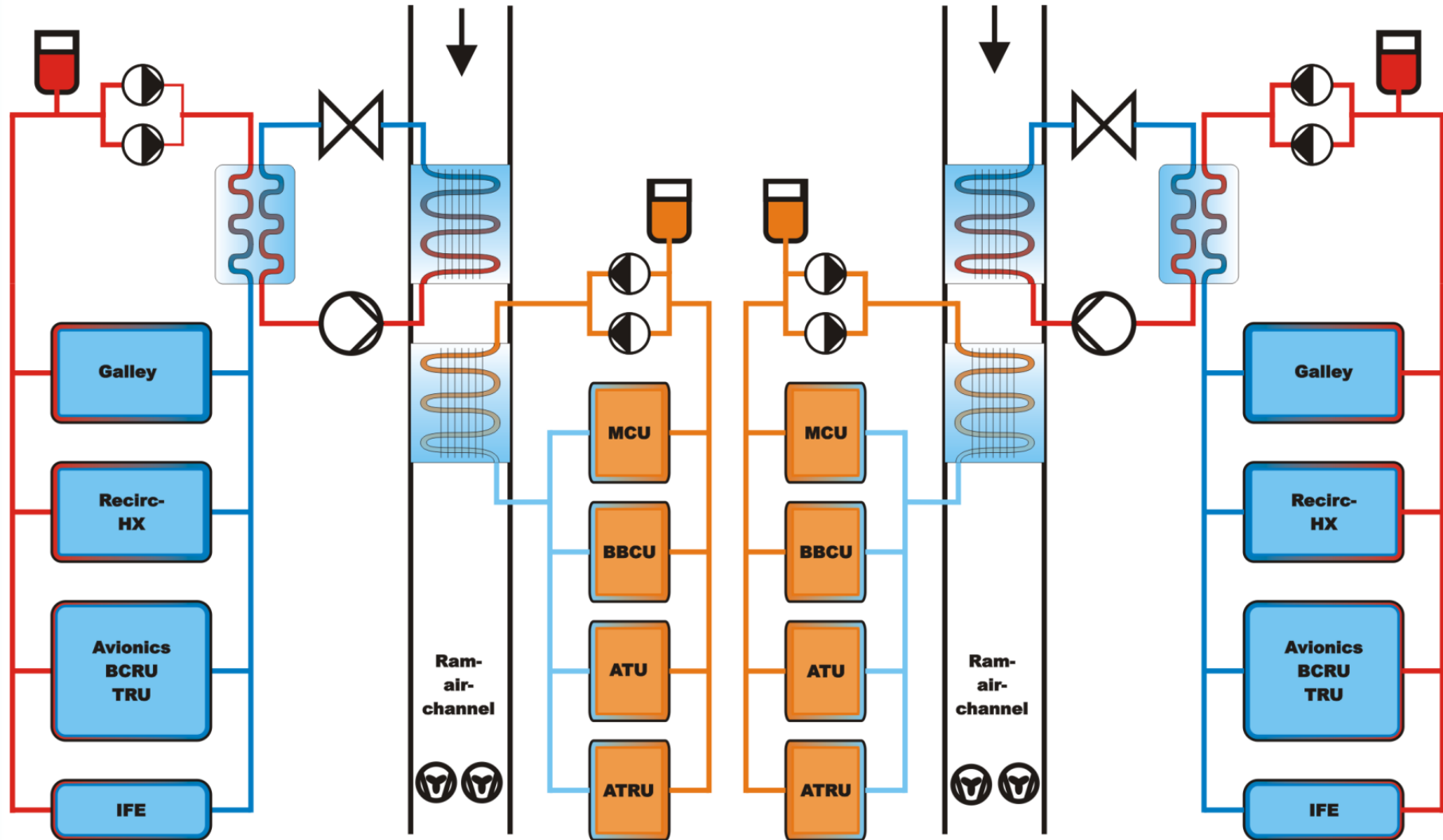

Cool plates investigations

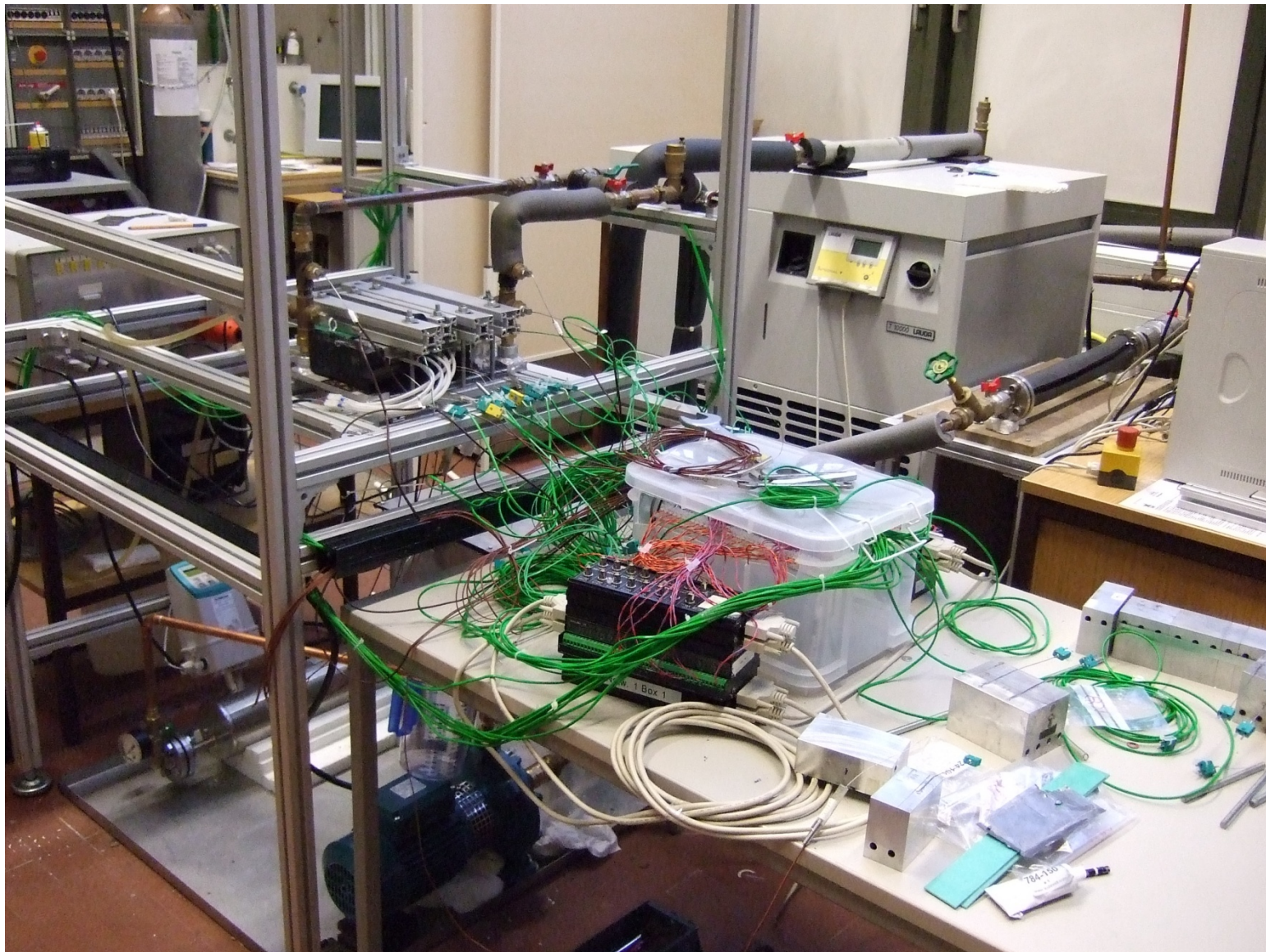

Air Inlet temperature: 20 °C

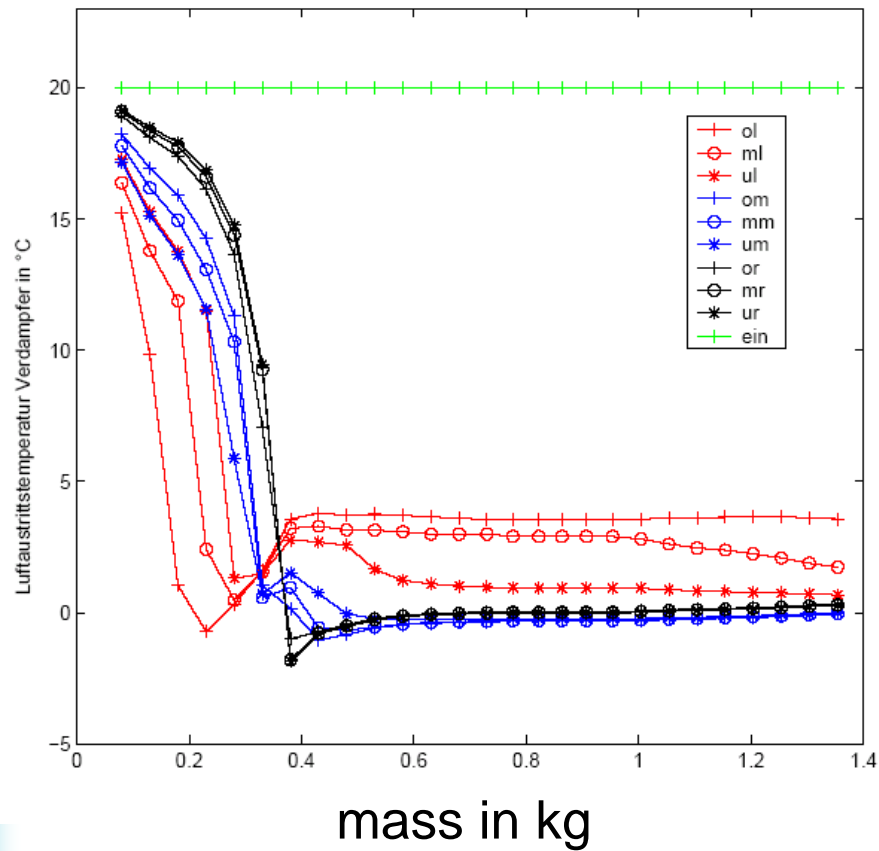

Air Inlet temperature: 40 °C

