

Example technologies and standards

Slides used in TDDE48 (Mobile Networks) @ LiU, Sweden, Fall 2023
Niklas Carlsson (<https://www.ida.liu.se/~nikca89/>)

Slides in this course are adapted or based on various on-line resources (including lectures notes by Juha Takkinen, Anirban Mahanti, Carey Williamson, Jim Kurose, and Keith Ross)

- The right technology/standard for the problem/environment??

Characteristics of selected wireless link standards

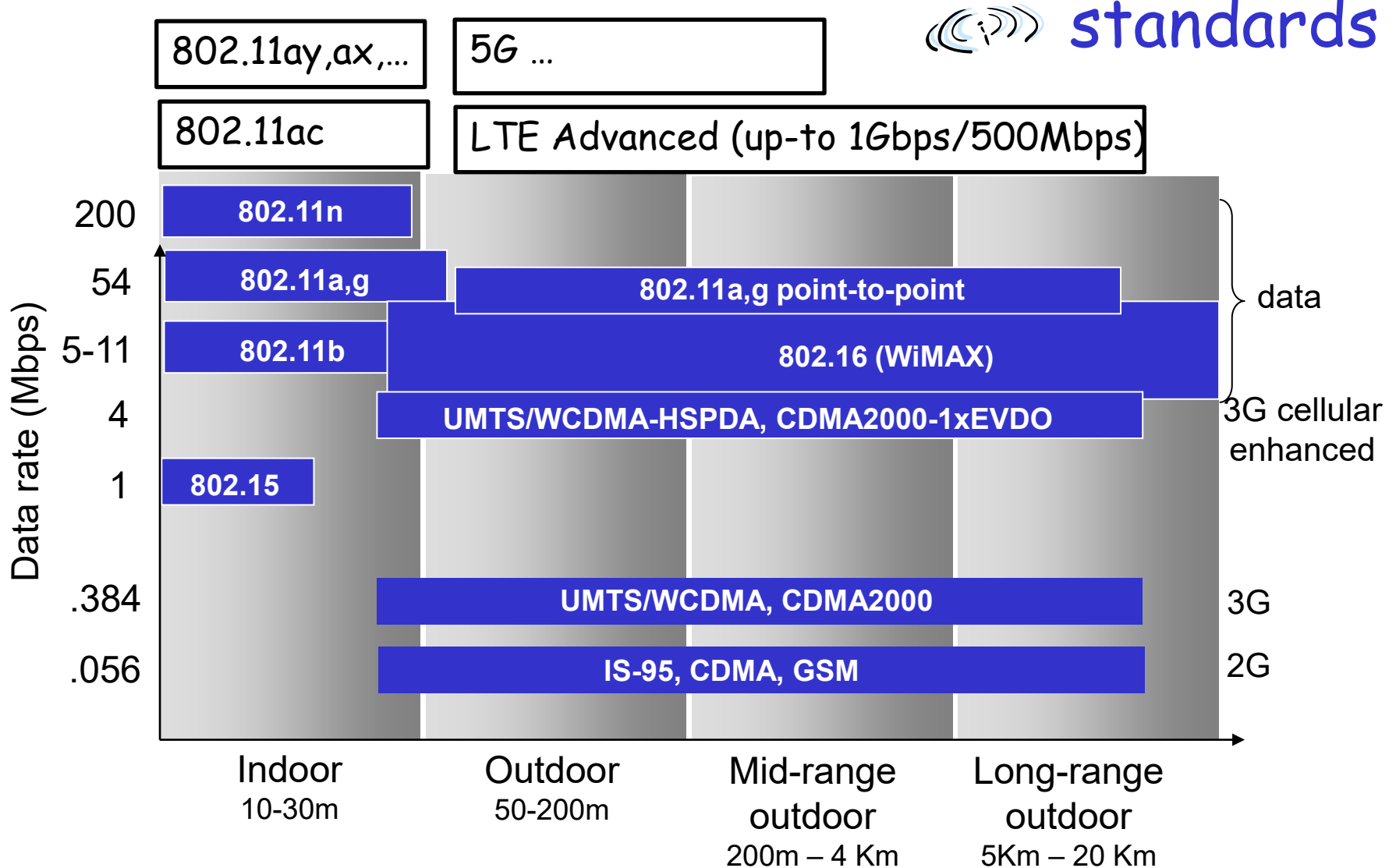

Characteristics of selected wireless links

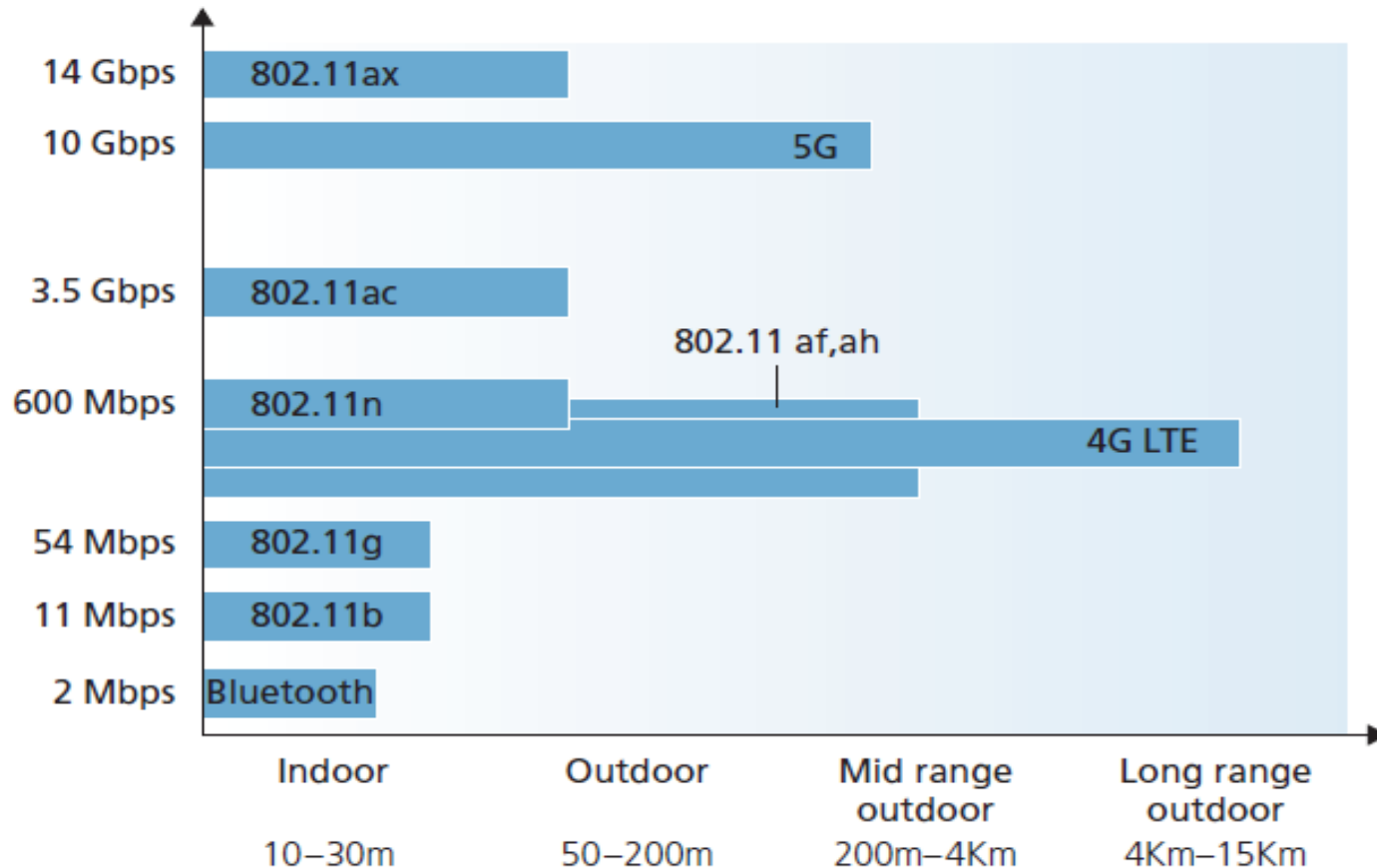

Figure 7.2 ♦ Wireless transmission rates and range for WiFi, cellular 4G/5G and Bluetooth standards (note: axes are not linear)

Differences in bandwidths primarily from ...

□ Physical layer

- Spectrum allocation (wave length)
- Frequency; channel width; time multiplexing
- Signal-to-Noise; BER; Error correction; etc.

□ MAC layer (sub-layer in data link layer)

- Multiple access techniques
- E.g., FDMA, TDMA, CDMA, SDMA, OFDMA

Frequency band spectrum

- spectrum allocated by global and national agencies

(Less sensitive to obstacles)
Low frequency

(More sensitive to obstacles)
High frequency



ELF (30-300Hz)

Telephone;
AM broadcast
Cell phone;
Satellite

Visible light
(400-900THz)

Microwave links

Multi-antenna (*slide from Ericsson)

Multi-Antenna Transmission Techniques

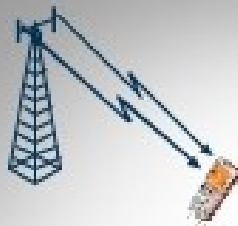

Diversity for improved system performance

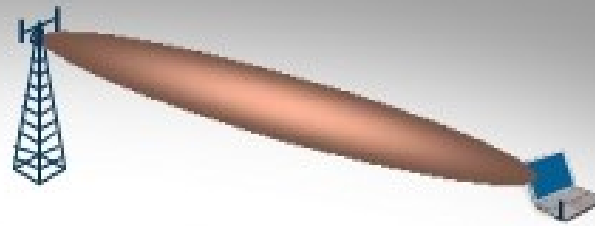

Beam-forming for improved coverage (less cells to cover a given area)

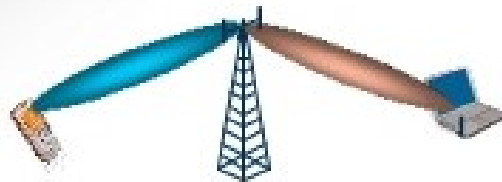

SDMA for improved capacity (more users per cell)

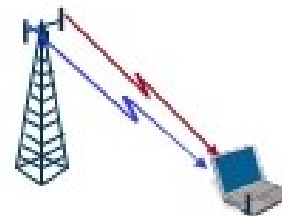

Multi-layer transmission ("MIMO") for higher data rates in a given bandwidth

The multi-antenna technique to use depends on what to achieve

802.11 LAN architecture

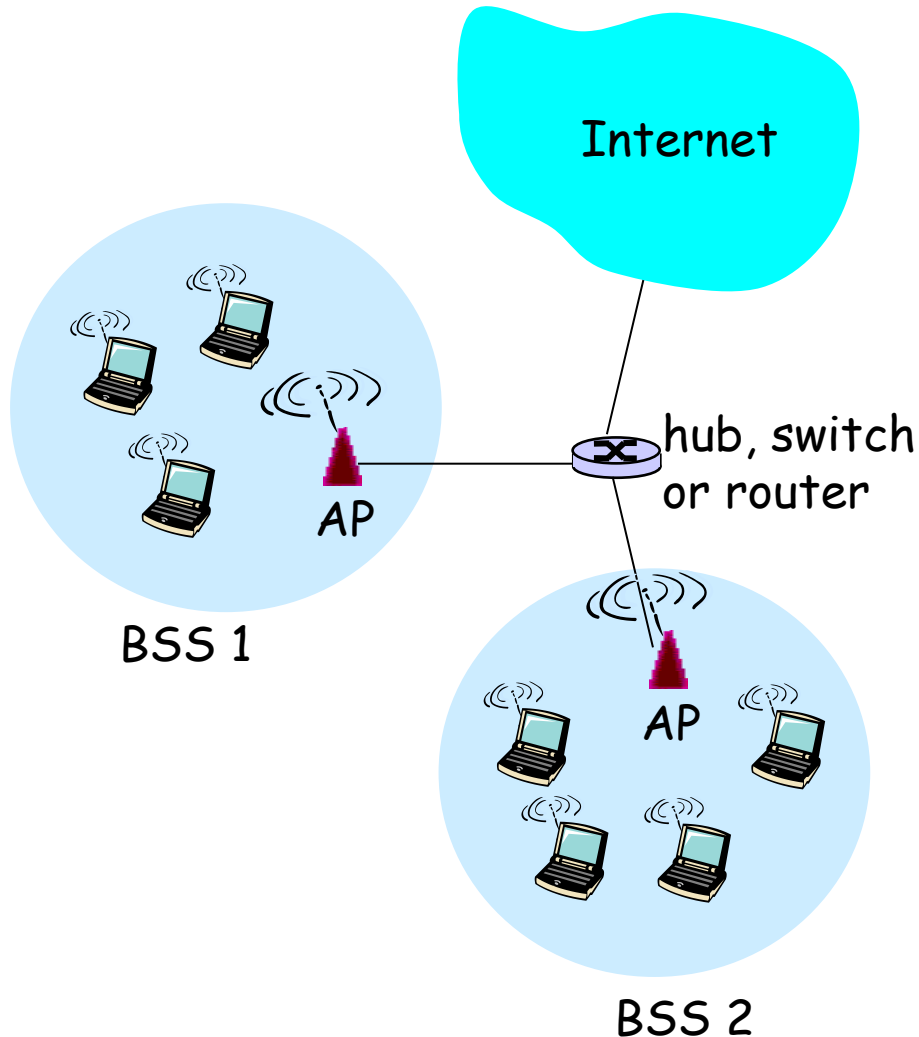

- Wireless host communicates with base station
 - base station = access point (AP)

- **Basic Service Set (BSS)** (aka "cell") in infrastructure mode contains:
 - wireless hosts
 - access point (AP)

 - ad hoc mode: hosts only

802.11: Cells, channels, association

- ❑ 802.11b has 11 channels
- ❑ Channels 1, 6, and 11 are non-overlapping

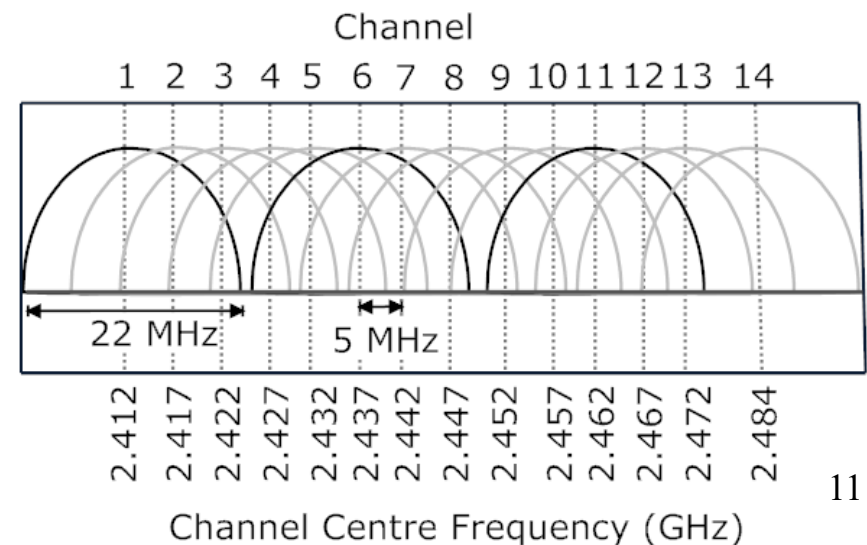

802.11: Cells, channels, association

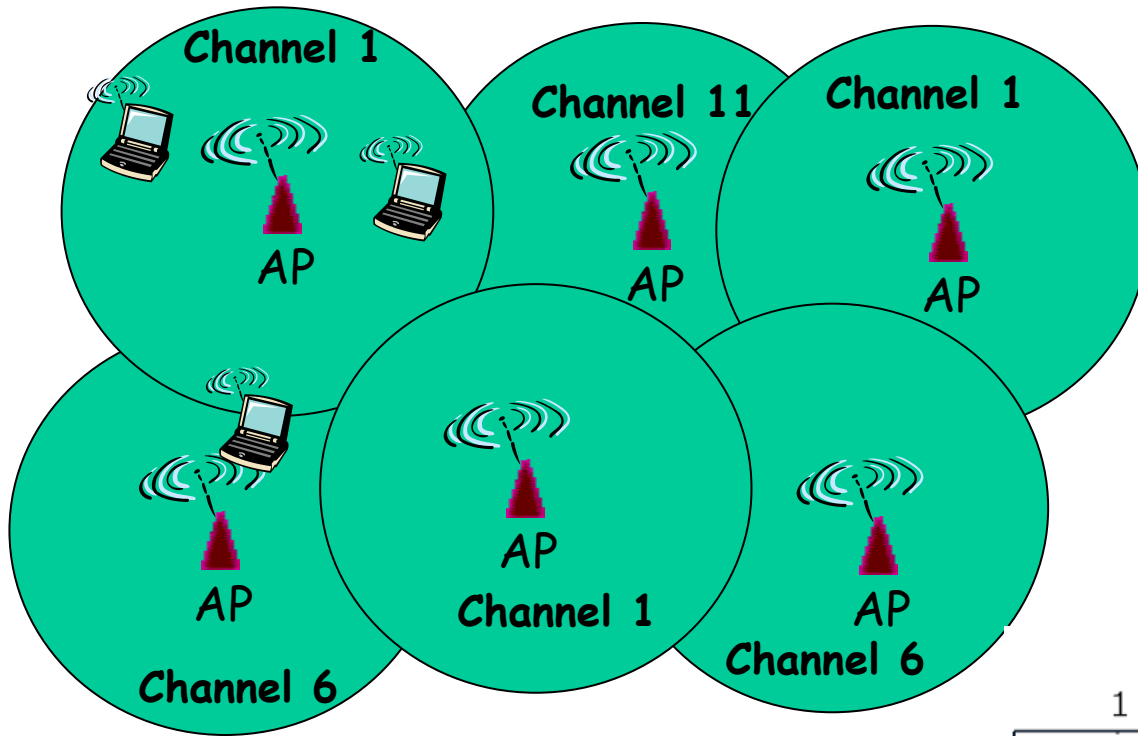

- ❑ 802.11b has 11 channels
- ❑ Channels 1, 6, and 11 are non-overlapping
- ❑ Each AP coverage area is called a "cell"
- ❑ Wireless nodes can roam between cells

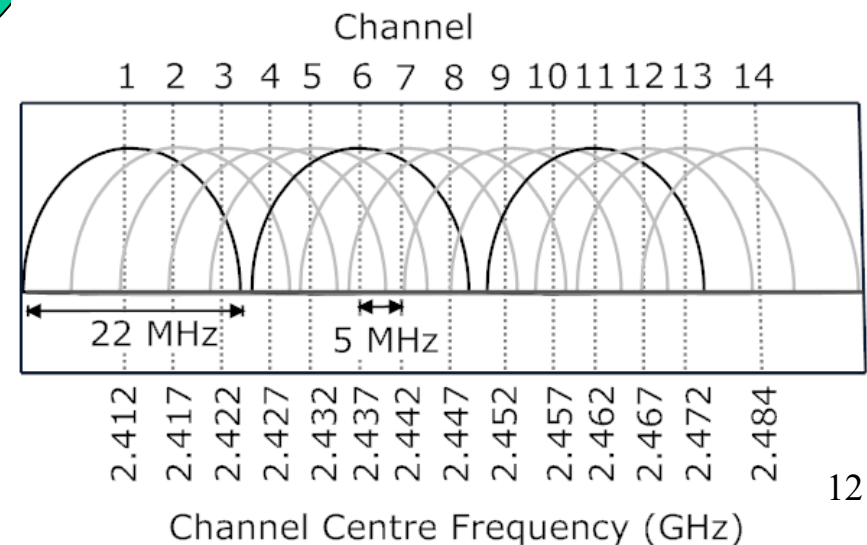

802.11: Cells, channels, association

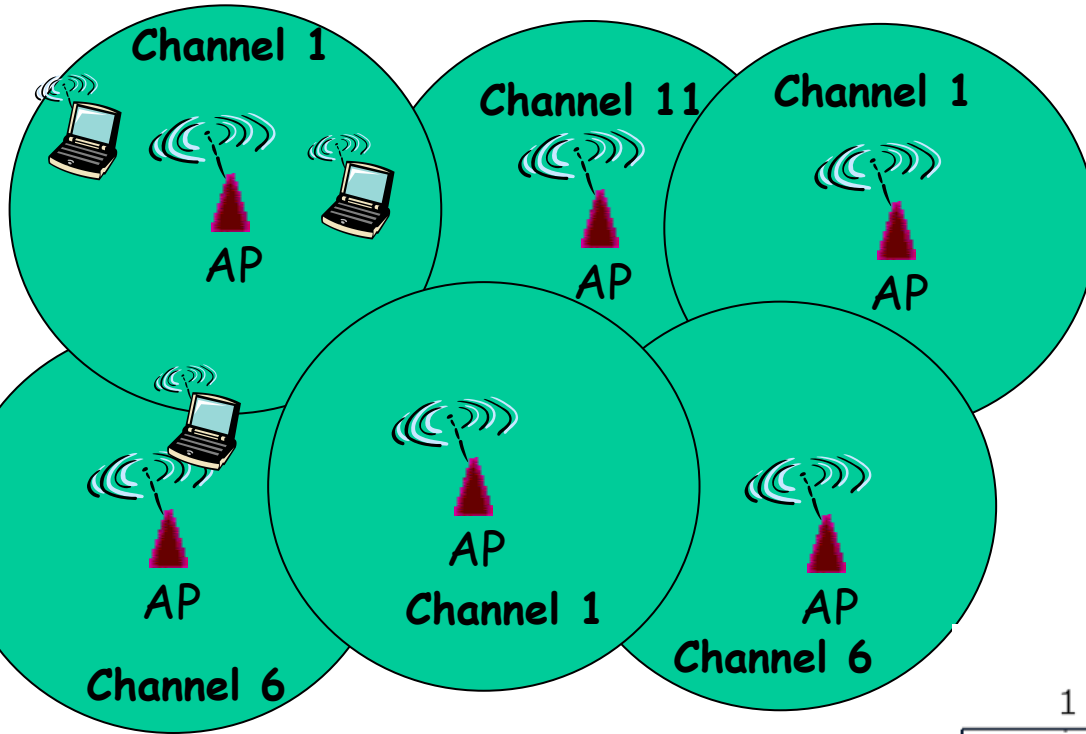

- ❑ 802.11b has 11 channels
- ❑ Channels 1, 6, and 11 are non-overlapping
- ❑ Each AP coverage area is called a "cell"
- ❑ Wireless nodes can roam between cells

- ❑ AP admin chooses frequency for AP
- ❑ interference possible: channel can be same as that chosen by neighboring AP!

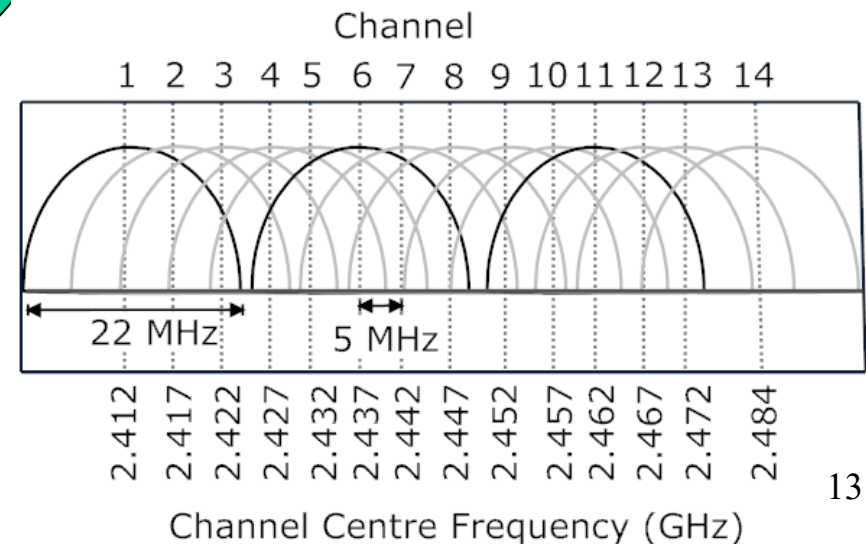

802.11: Cells, channels, association

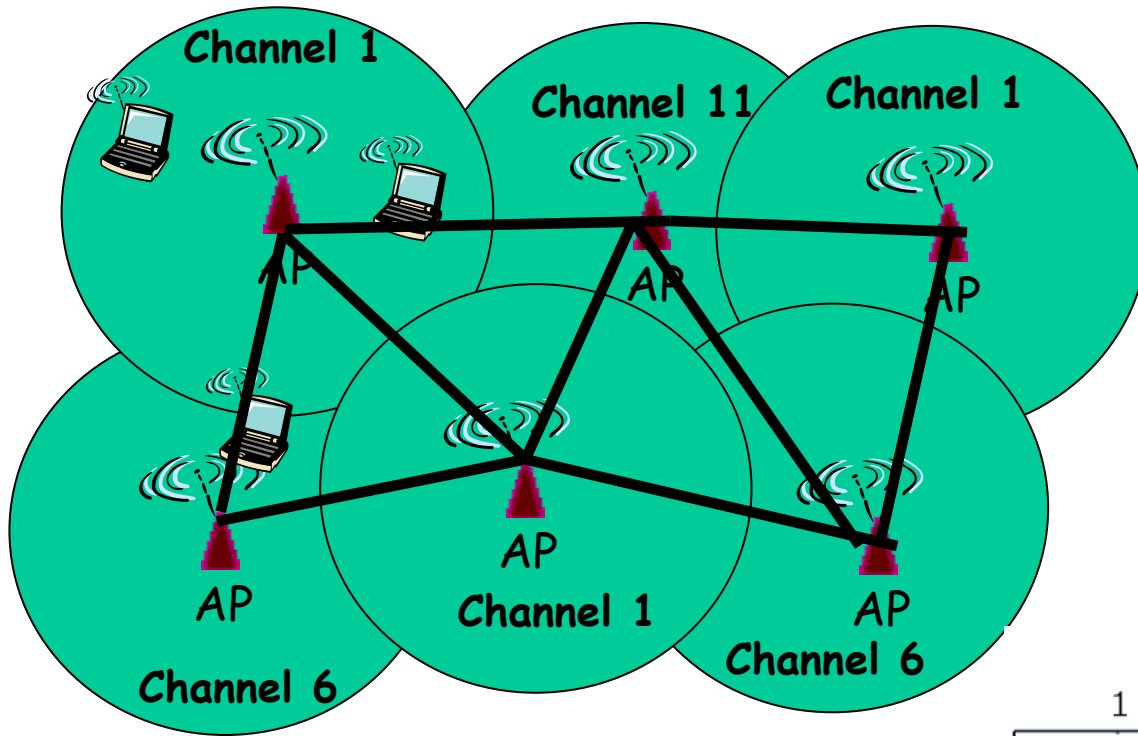

- ❑ 802.11b has 11 channels
- ❑ Channels 1, 6, and 11 are non-overlapping
- ❑ Each AP coverage area is called a "cell"
- ❑ Wireless nodes can roam between cells

- ❑ AP admin chooses frequency for AP
- ❑ interference possible: channel can be same as that chosen by neighboring AP!

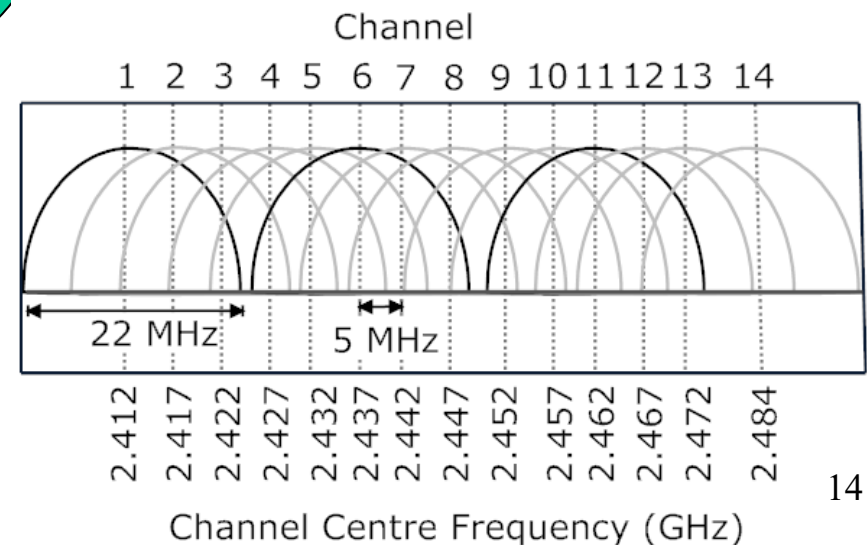

802.11: Cells, channels, association

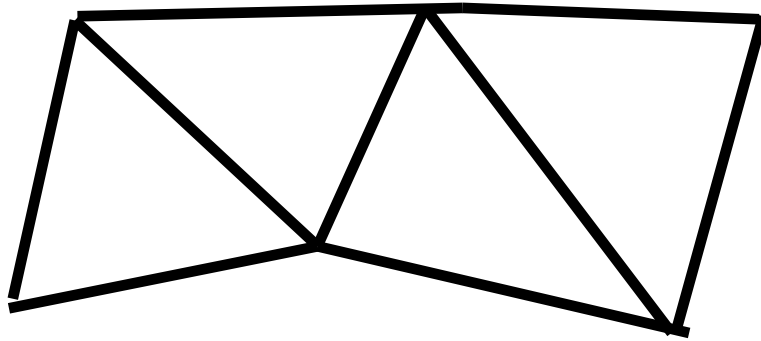

- ❑ 802.11b has 11 channels
- ❑ Channels 1, 6, and 11 are non-overlapping
- ❑ Each AP coverage area is called a "cell"
- ❑ Wireless nodes can roam between cells

- ❑ AP admin chooses frequency for AP
- ❑ interference possible: channel can be same as that chosen by neighboring AP!

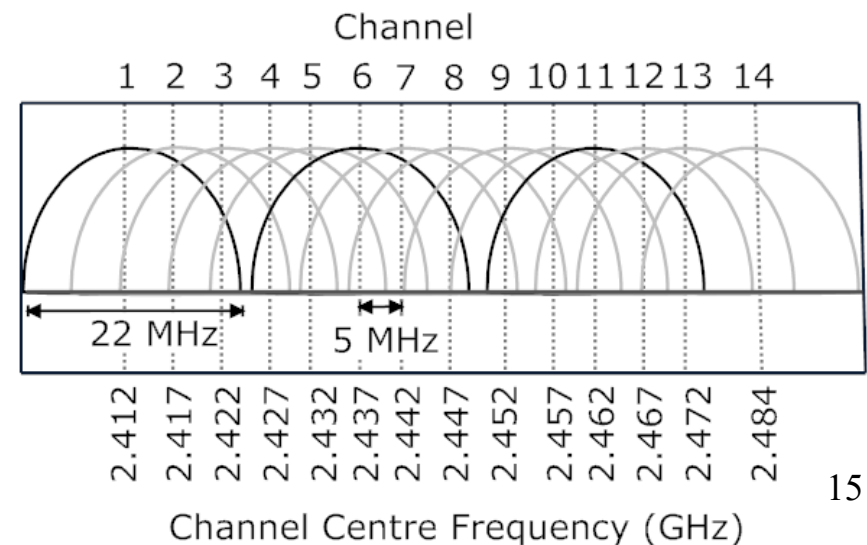

802.11: Cells, channels, association

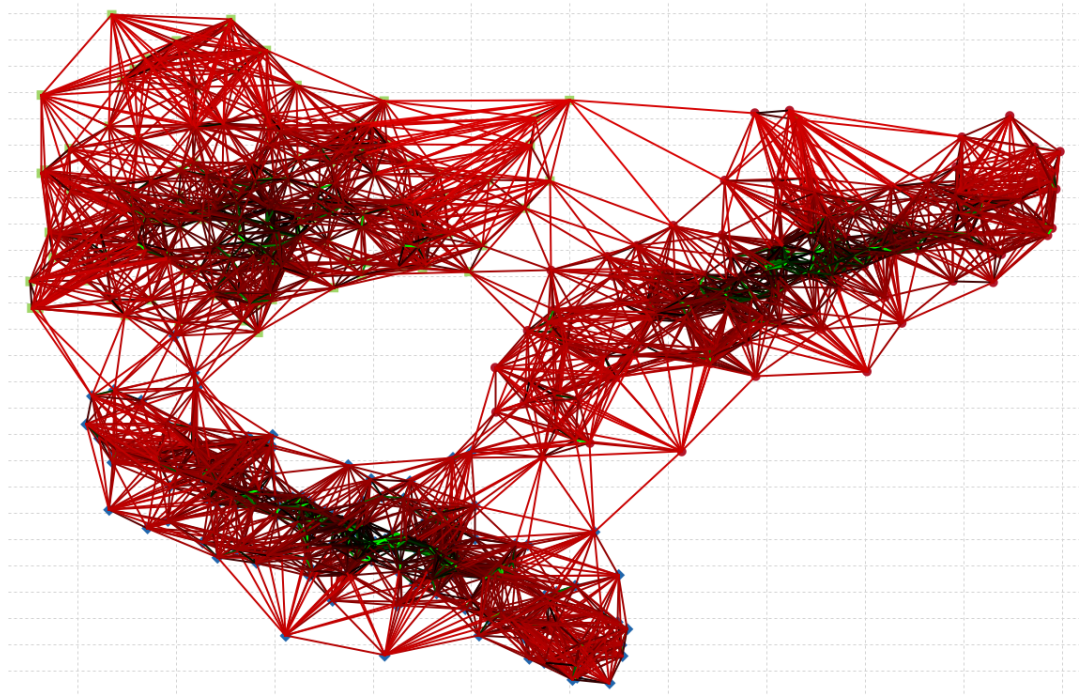
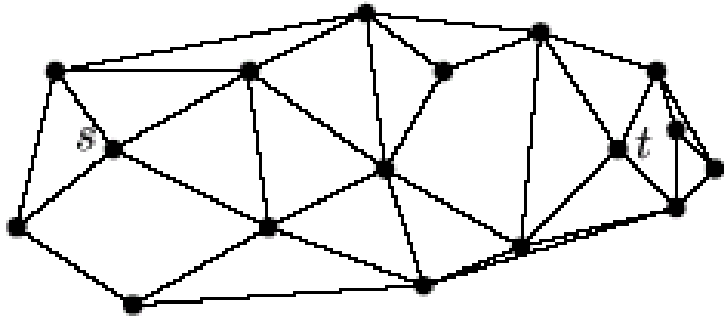

- ❑ AP admin chooses frequency for AP
- ❑ interference possible: channel can be same as that chosen by neighboring AP!

802.11: Cells, channels, association

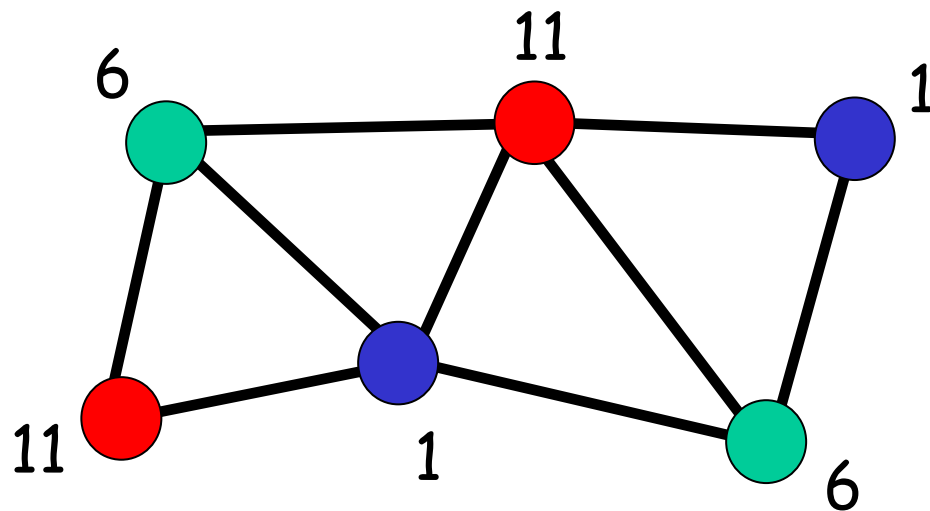

- Graph abstraction and coloring ...
- A non-interfering solution exists if there exists a 3-coloring of the neighbor graph
- Of course. similar problems occurs in other wireless networks (and their applications) ...

802.11: Channels, association

- host: must *associate* with an AP
 - scans channels, listening for *beacon frames* containing AP's name (SSID) and MAC address
 - selects AP to associate with
 - may perform authentication
 - typically run DHCP to get IP address in AP's subnet

802.11: passive/active scanning

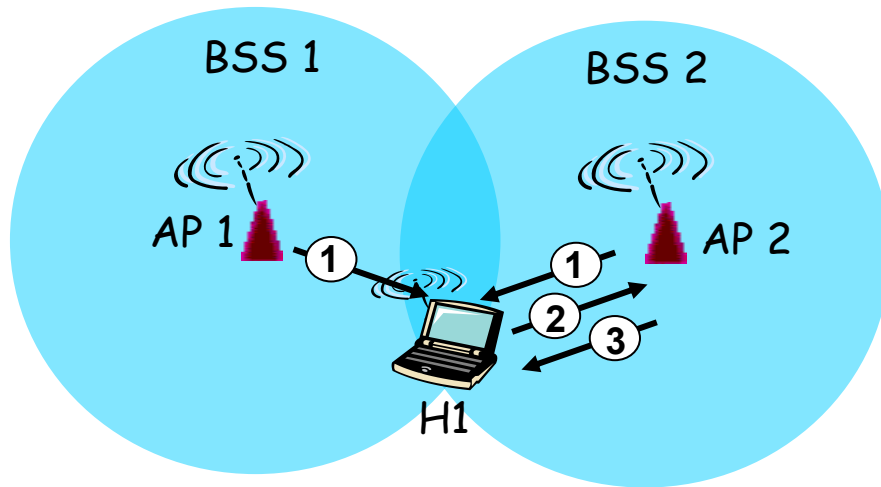

Passive Scanning:

- (1) Beacon frames sent from APs
- (2) Association Request frame sent:
H1 to selected AP
- (3) Association Response frame sent:
selected AP to H1

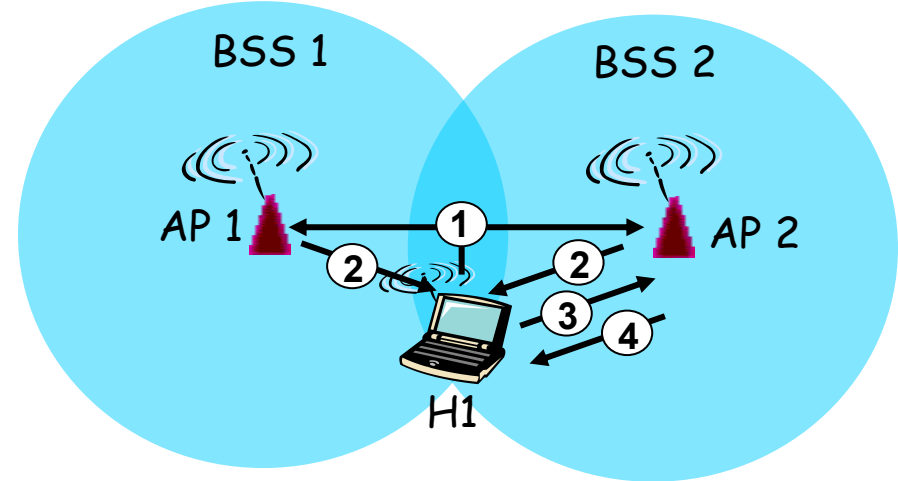

Active Scanning:

- (1) Probe Request frame broadcast
from H1
- (2) Probes response frame sent
from APs
- (3) Association Request frame
sent: H1 to selected AP
- (4) Association Response frame
sent: selected AP to H1

802.11 frame: addressing

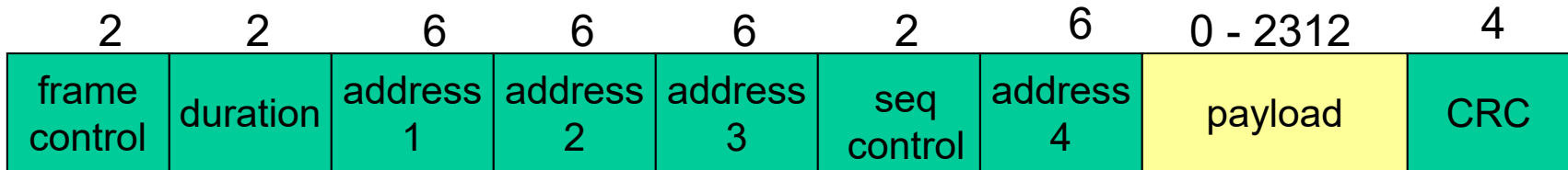

Address 1: MAC address of wireless host or AP to receive this frame

Address 2: MAC address of wireless host or AP transmitting this frame

Address 3: MAC address of router interface to which AP is attached

Address 4: used only in ad hoc mode

802.11 frame: addressing

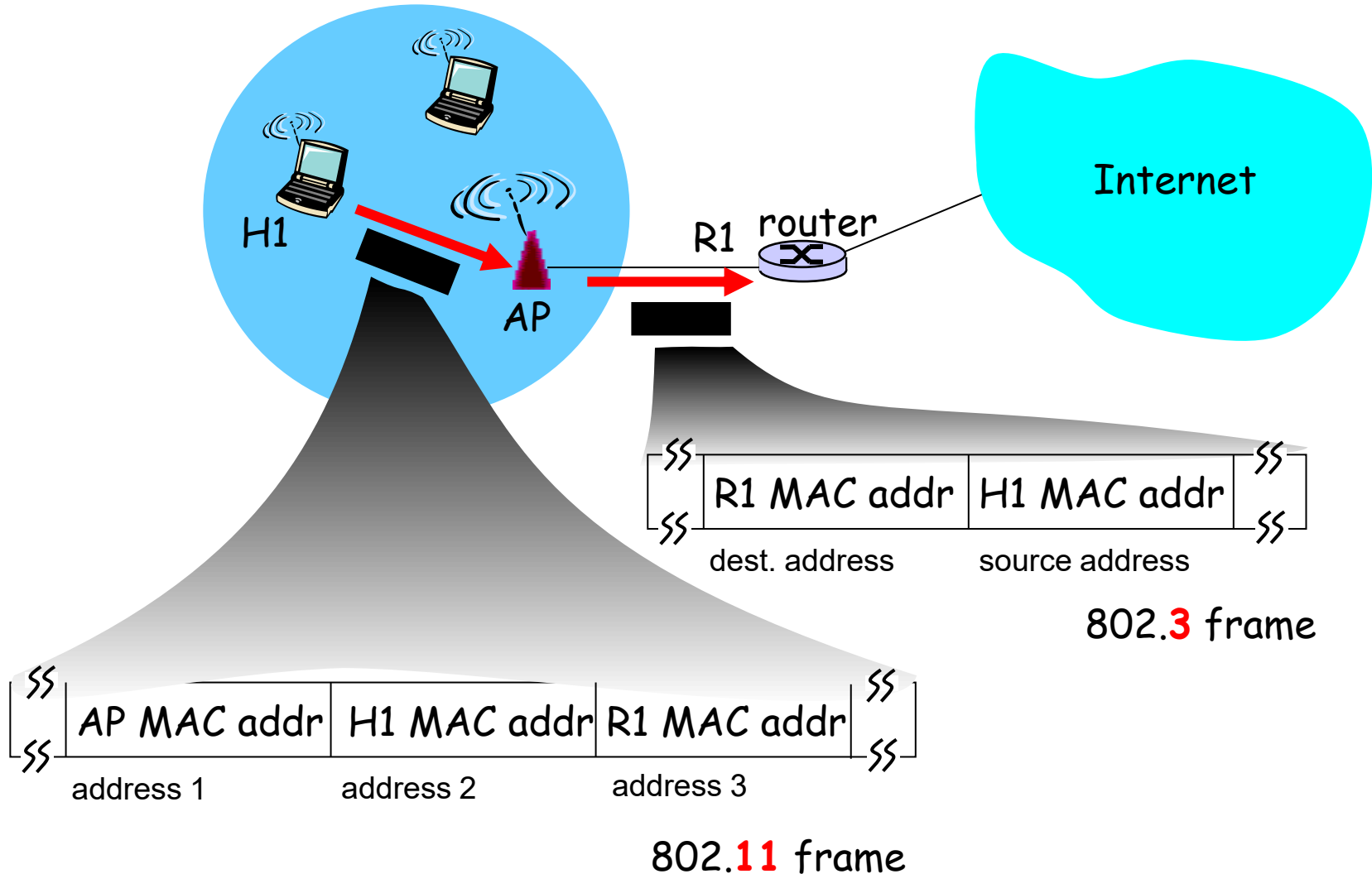

802.11: advanced capabilities

Rate Adaptation

- base station, mobile dynamically change transmission rate (physical layer modulation technique) as mobile moves, SNR varies

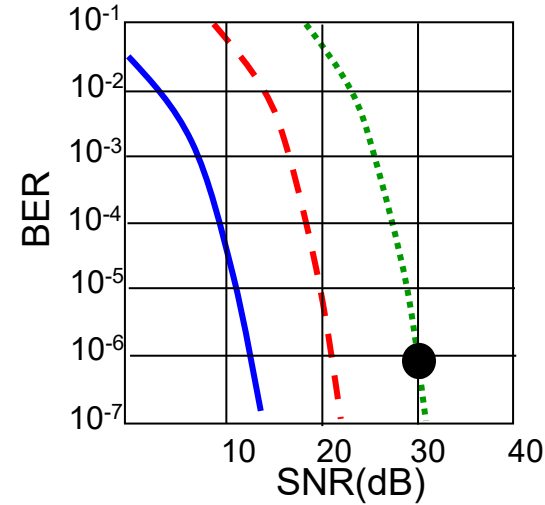
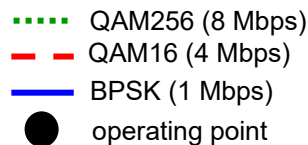

1. SNR decreases, BER increase as node moves away from base station
2. When BER becomes too high, switch to lower transmission rate but with lower BER

802.11: advanced capabilities

Power Management

- ❑ node-to-AP: "I am going to sleep until next beacon frame"
 - AP knows not to transmit frames to this node
 - node wakes up before next beacon frame
- ❑ beacon frame: contains list of mobiles with AP-to-mobile frames waiting to be sent
 - Every 100ms (250 μ s wakeup time)
 - node will stay awake if AP-to-mobile frames to be sent; otherwise sleep again until next beacon frame
 - Explicit pull request

Note: Nodes with nothing to send/receive can save 99% of energy

A typical Bluetooth data frame

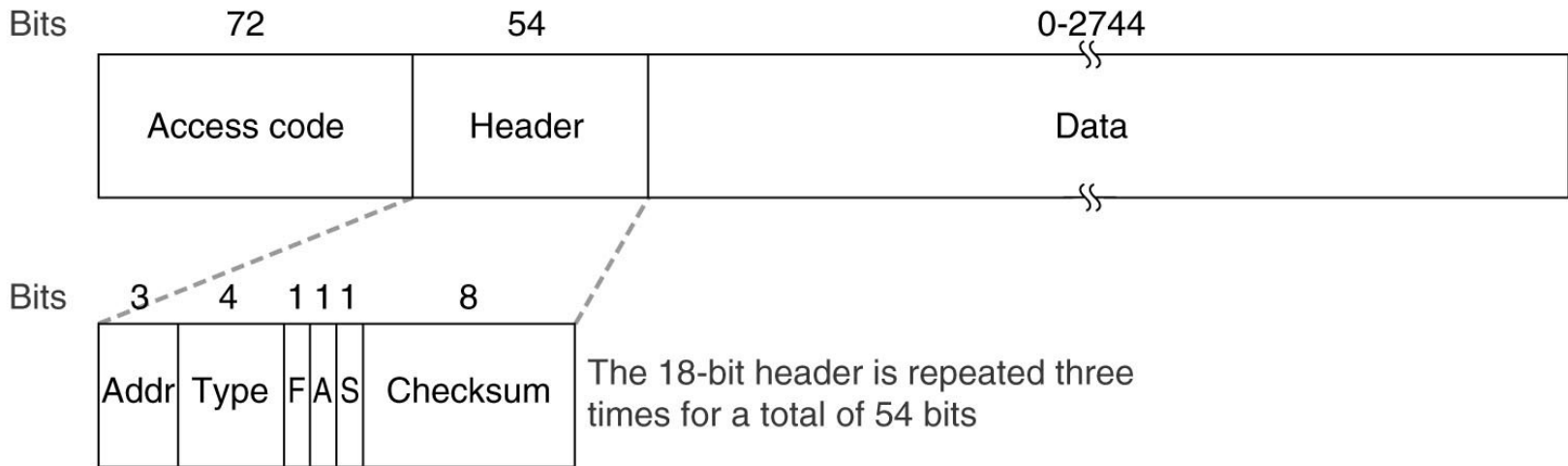

Bluetooth Networking

Piconets: Bluetooth devices are organized in local networks called **piconets**

- ❑ up to 8 devices can be part of a piconet
- ❑ devices divided in **master** and **slaves (*)**
- ❑ a **slave** may communicate only with the master and when allowed by the master
- ❑ the **master** controls the utilization of the radio channel (e.g. frequency-hopping sequence + timing)

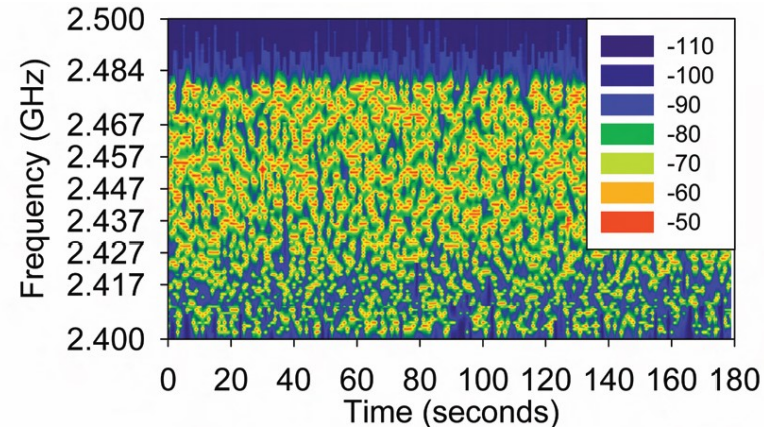

Scatternets: Network formed by several connected piconets

- ❑ A device may belong to different piconets and may be both a master and a slave in two different piconets

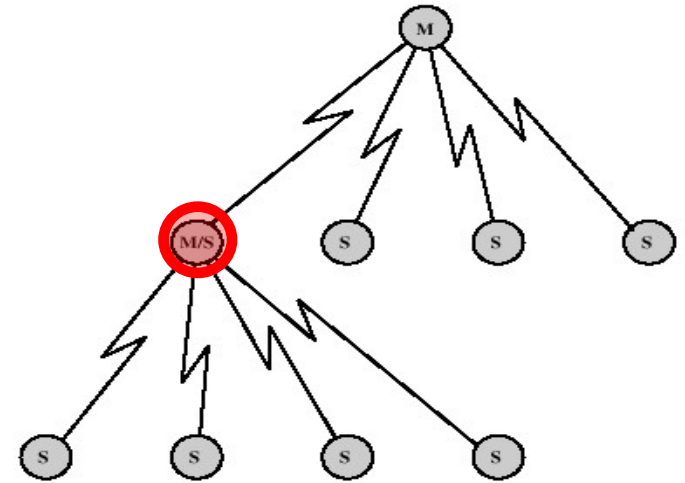

* Master/slave terminology is not deemed appropriate. Changes (driven by increased awareness ...) are expected. For example, Twitter is changing their documentation + code to use leader/follower (not master/slave): <https://www.bbc.com/news/business-53273923>

802.15: personal area network (PAN)

- ❑ less than 10 m diameter
- ❑ replacement for cables (mouse, keyboard, headphones)
- ❑ ad hoc: no infrastructure
- ❑ master/slaves:
 - slaves request permission to send (to master)
 - master grants requests
- ❑ 802.15: evolved from Bluetooth specification
 - 2.4-2.5 GHz radio band
 - up to 721 kbps

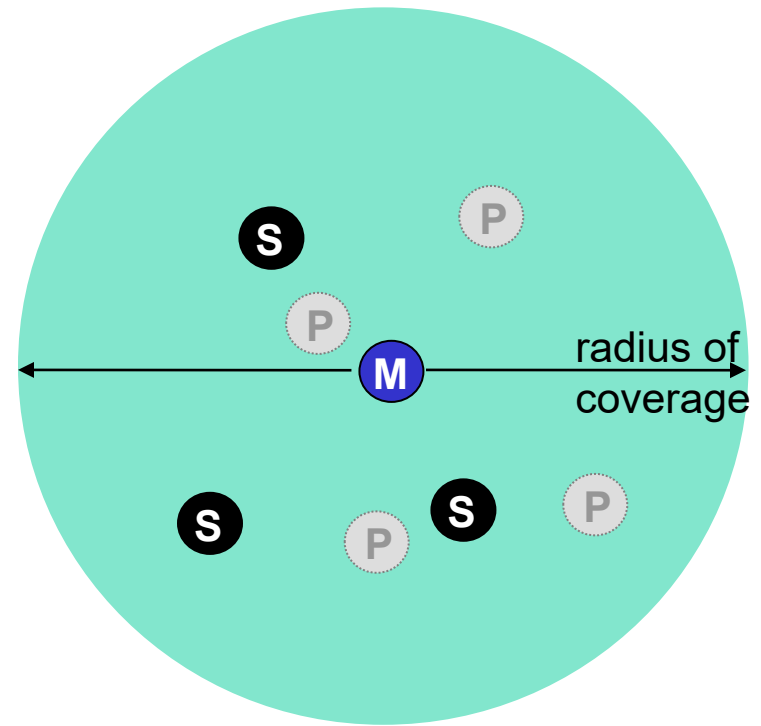

- M** Master device
- S** Slave device
- P** Parked device (inactive)

Two Popular 2.4 GHz Standards:

□ IEEE 802.11 (WiFi)

- Fast (11 Mbps)
- High power
- Long range
- Single-purpose
- Typically channel 1, 6, or 11
- Ethernet replacement
- Easily available

□ Bluetooth

- Slow (1 Mbps)
- Low power
- Short range
- Flexible
- Frequency hopping
- Cable replacement (e.g., device-to-device)

Example

□ What technology/device?

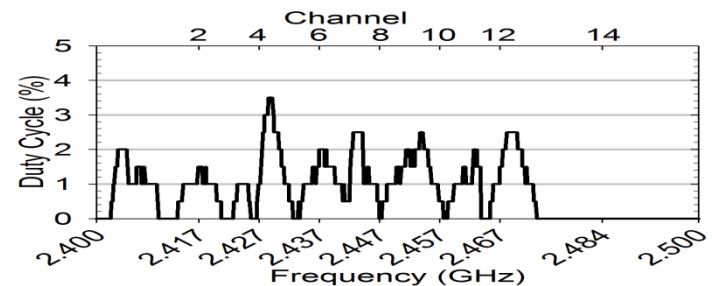
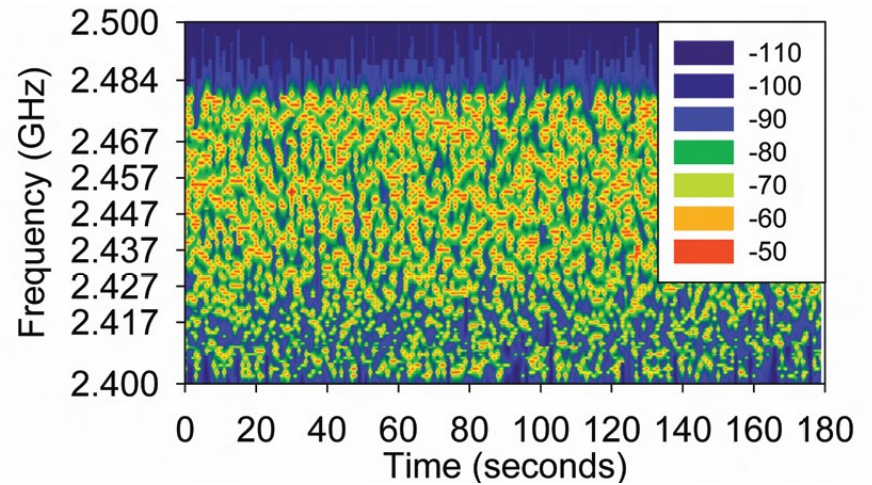
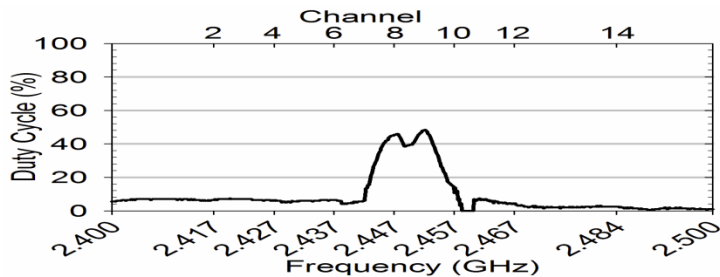
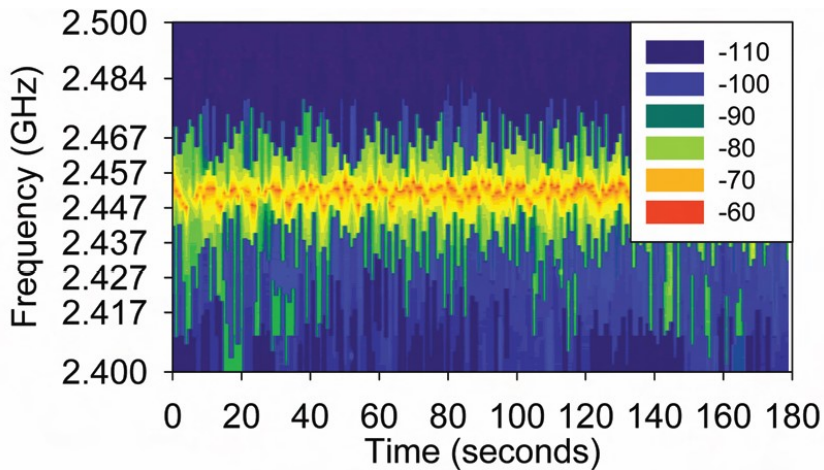

Example

Figures from:

A. Mahanti et al., "Ambient Interference Effects in Wi-Fi Networks", *Proc. IFIP Networking*, 2010.

- Many devices and technologies share the medium ... results in time varying interference

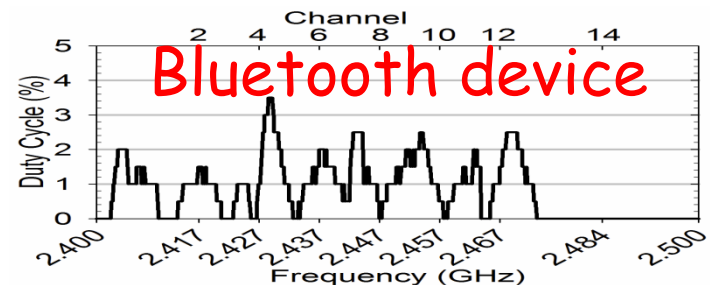
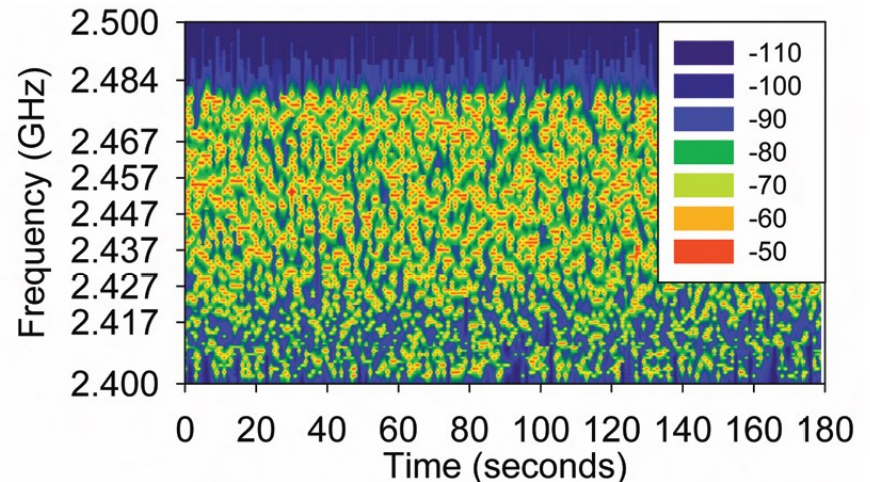
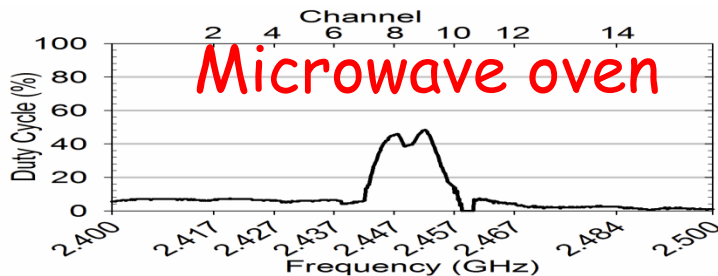
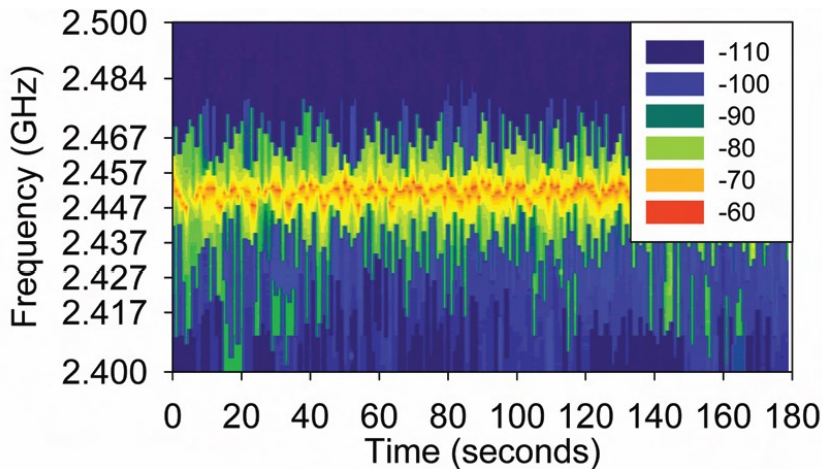

Example: Channel Utilization

- Many devices and technologies share the medium ... results in time varying interference

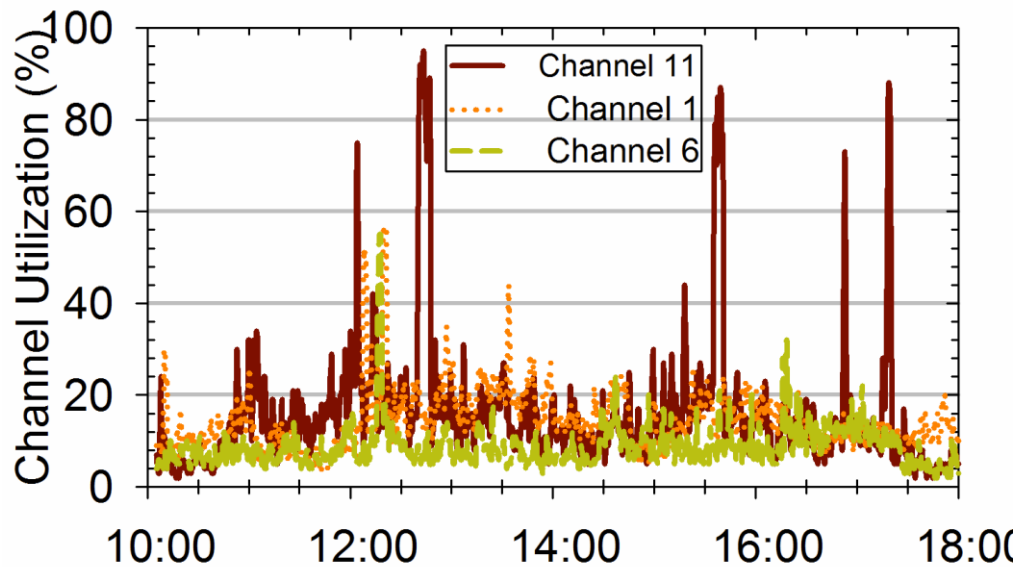

Figure from:
A. Mahanti et al., "Ambient Interference Effects in Wi-Fi Networks", *Proc. IFIP Networking*, 2010.

- **Channel utilization:** The % of time a transmission is present from a known RF source, in a given channel
- Channels 1 and 6, utilization peaked near 60%, while for channel 11 it was over 90%.
- Channel 11 spikes caused due to microwave ovens, cordless phones, and other fixed-frequency devices.

802.16: WiMAX (MAN)

- like 802.11 & cellular:
base station model
 - transmissions to/from base station by hosts with omnidirectional antenna
 - base station-to-base station backhaul with point-to-point antenna

- unlike 802.11:
 - range ~ 6 miles ("city rather than coffee shop")

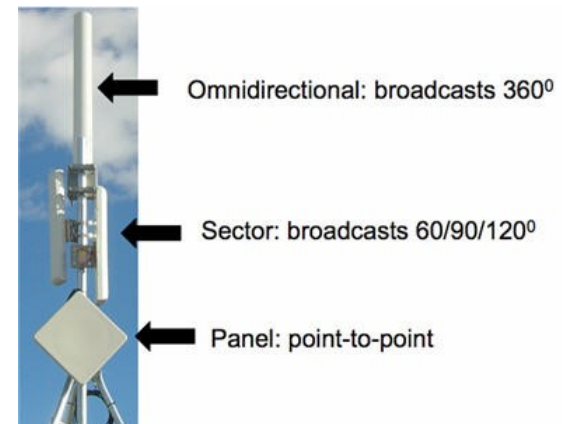
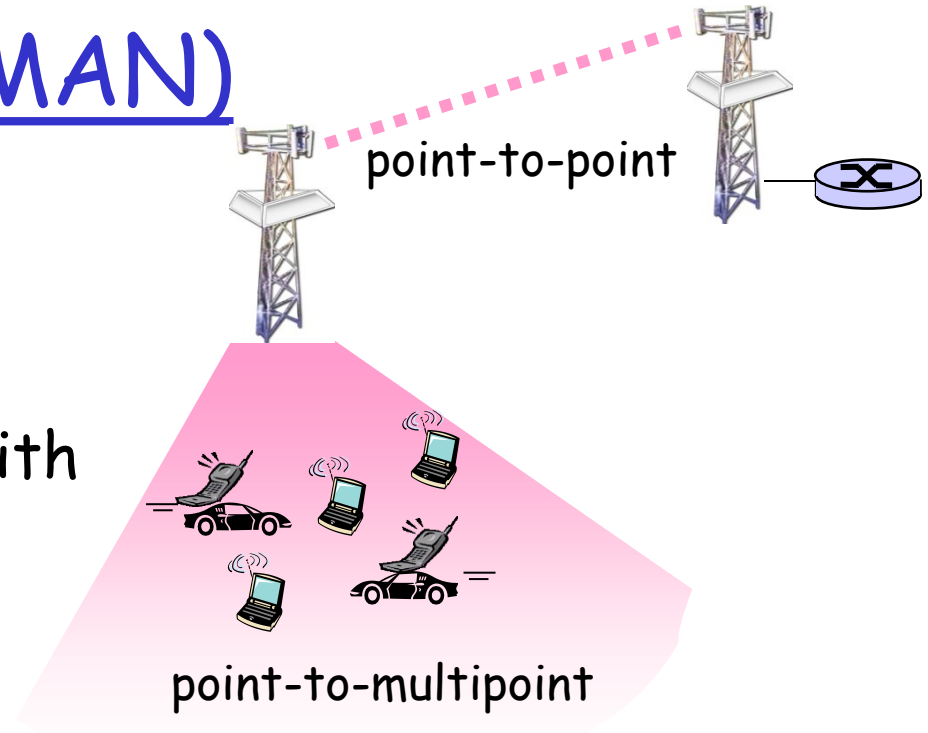

802.16: WiMAX: downlink, uplink scheduling

- transmission frame
 - down-link subframe: base station to node
 - uplink subframe: node to base station

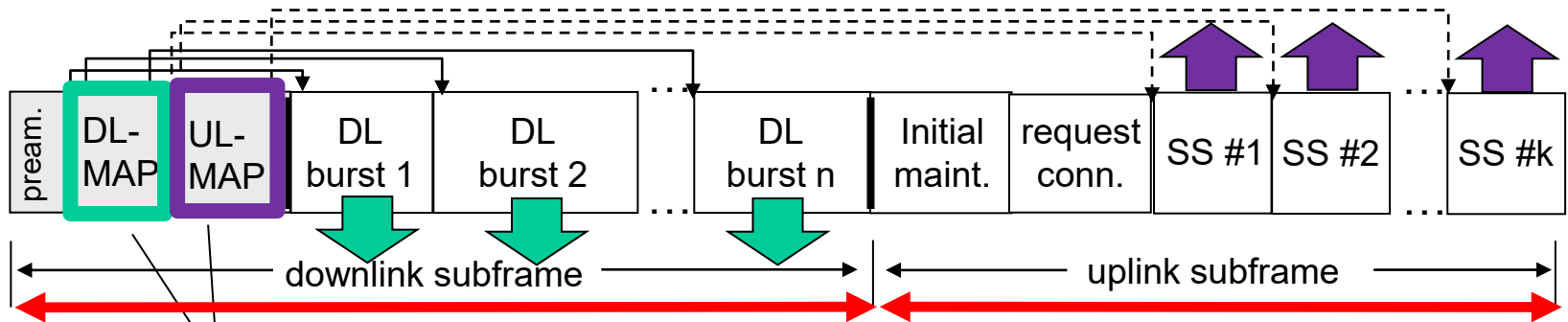

base station tells nodes who will get to receive (DL map)
and who will get to send (UL map), and when

Repeat ...

- WiMAX standard provide mechanism for scheduling, but not scheduling algorithm
 - Note: This separation between standardized mechanisms and scheduling/optimization common

Components of a 3G network

cell

- covers geographical region
- **base station** (BS) analogous to 802.11 AP
- **mobile users** attach to network through BS
- **air-interface:** physical and link layer protocol between mobile and BS

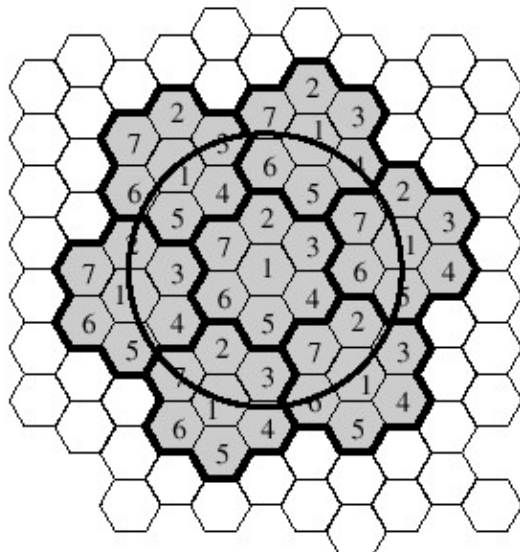

MSC

- connects cells to wide area net
- manages call setup (more later!)
- handles mobility (more later!)

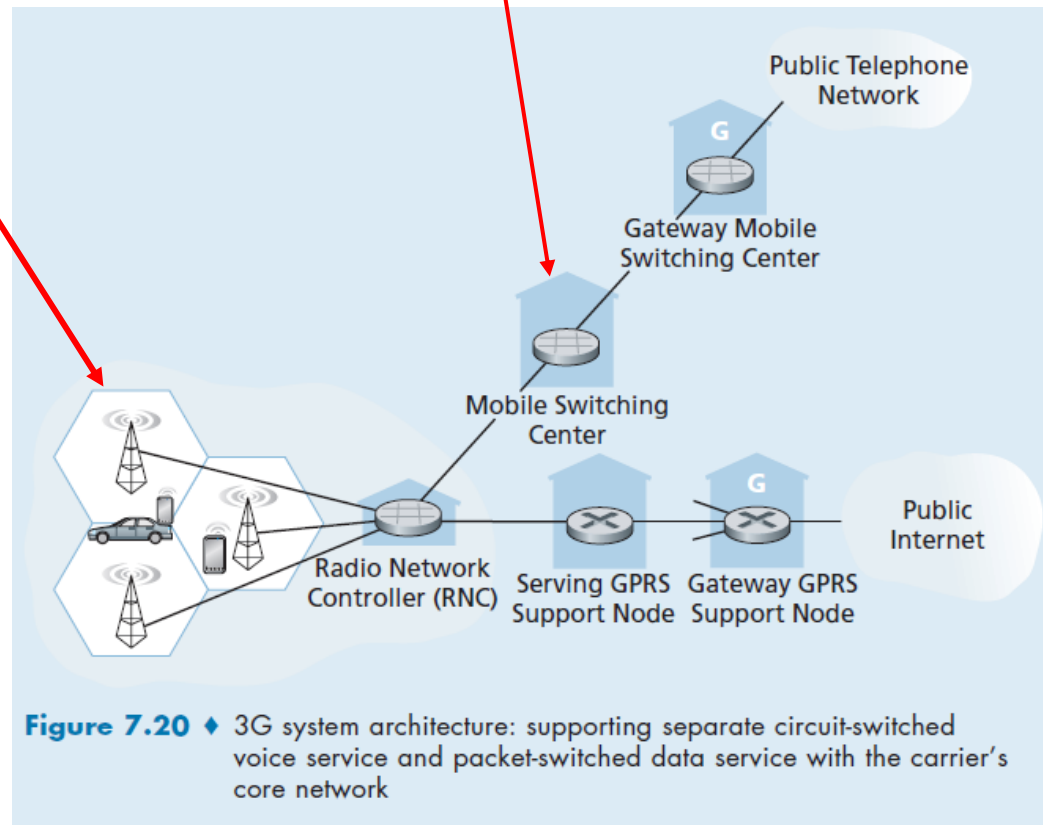

Components of a 4G network

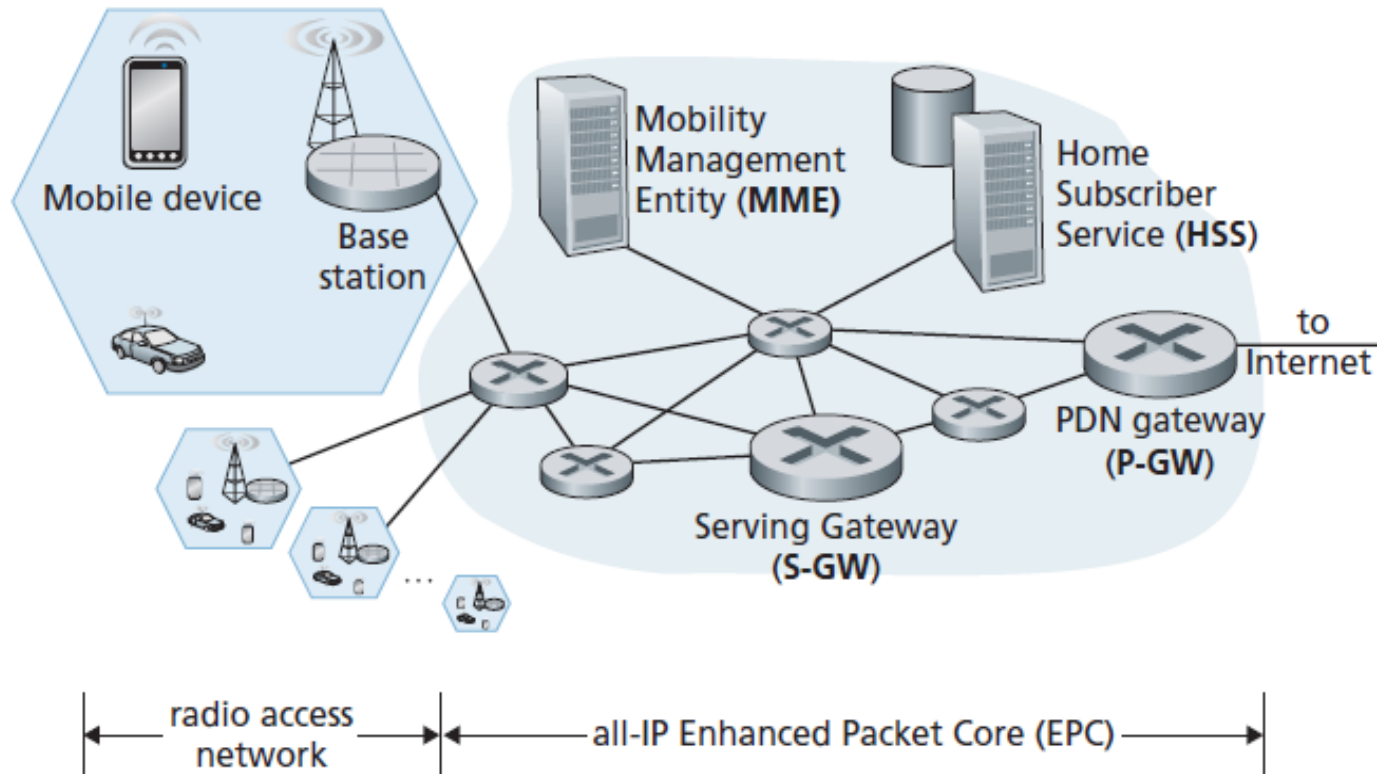

Figure 7.17 ♦ Elements of the 4G LTE architecture

More slides (e.g., if time)

Other PAN example (even lower energy): The ANT protocol stack

- Wireless sensor communications protocol stack
 - 2.4 GHz RF spectrum (i.e., the ISM band)
 - Establishes rules for co-existence, data representation, signaling, authentication, and error detection

- Low computational overhead and high efficiency
 - Low power consumption by the radios

- Targeted at the sports sector, particularly fitness and cycling performance monitoring.
 - Transceivers are embedded in equipment such as heart rate belts, watches, cycle power and cadence meters, and distance and speed monitors